

CRYSTEEL'S MARATHON

TELESCOPIC HOIST



P.O. Box 178
52182 Ember Road
Lake Crystal, MN 56055

www.crysteel.com
crysteel@crysteel.com
(507) 726-2728 (800) 533-0494

1902 Route 57 South
Fulton, NY 13069

DATE PURCHASED _____
BODY SERIAL NUMBER _____
HOIST SERIAL NUMBER _____
CYLINDER SERIAL NUMBER _____
DEALER _____
ADDRESS _____
PHONE _____

FOREWORD

Crysteel's Marathon hoist is a heavy duty, front-mount telescopic hoist designed and intended for use under dump bodies. The Marathon hoist is available with either a single-acting or a double-acting cylinder. The Marathon hoist line consists of 8 sizes that fit single-, tandem- and triple-axle trucks with body lengths from 9 feet through 21 feet.

This manual contains the information needed for the proper installation and operation of Crysteel's Marathon hoist. Study it carefully before attempting to mount or use these products. With proper installation and maintenance, the Marathon Hoist and Crysteel Body will give many years of trouble-free service.

When ordering parts, be sure to give serial number of hoist, pump, and cylinder. The serial number of the pump is found on the plate on the pump. The serial number of the cylinder is stamped on the barrel of the cylinder near the base. For future reference, copy these numbers NOW in the space provided above. Order parts by number and description as given in the parts listing in this manual.

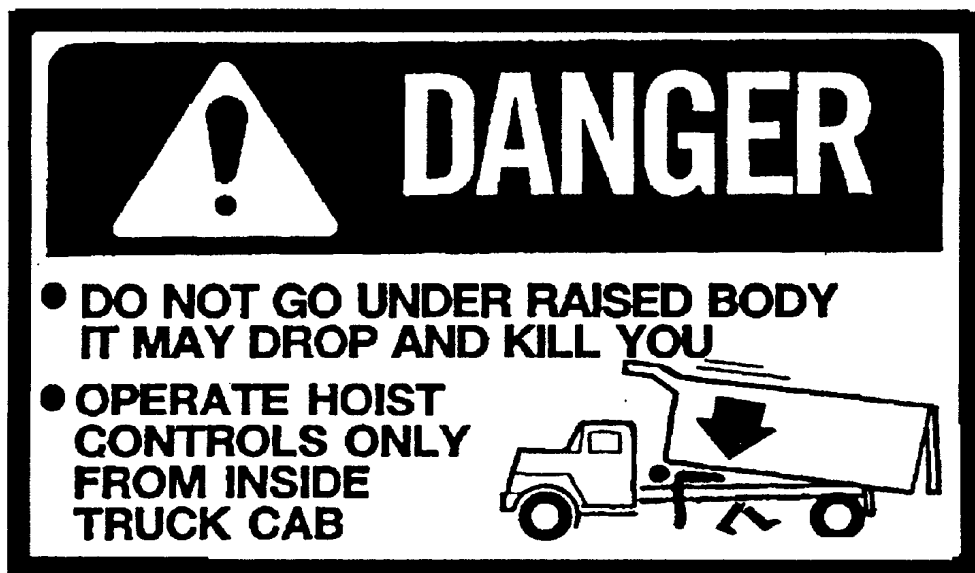

KEEP THIS MANUAL IN A SAFE PLACE FOR FUTURE REFERENCE

OPERATION AND USE

1. Engage PTO from cab and adjust engine speed to fast idle.
2. The hoist should raise when the hoist control lever is pulled back, hold when the lever is in the center detent, and lower when the lever is pushed forward.
3. To raise the hoist, pull the control lever back. To hold the body in a raised position, place the control lever in its center detent position. To lower the hoist, push the control lever forward.
4. **ALWAYS** return the hoist control lever to its center detent position after each use.
5. **DO NOT LEAVE THE PTO IN GEAR WHILE TRANSPORTING. THIS CAN CAUSE SEVERE DAMAGE TO THE PTO OR HYDRAULIC PUMP/VALVE.**
6. The hydraulic system should be drained, flushed and refilled with proper hydraulic fluid at regular intervals. **CAUTION: NEVER use hydraulic BRAKE FLUID in the hydraulic system.**

SOME DO'S AND DON'TS FOR SAFE AND LONG SERVICE

1. Use the proper hydraulic fluid. **KEEP IT CLEAN.** Remember to change it regularly.
2. Lubricate all grease fittings at regular intervals.
3. **ALWAYS** carefully block up the body, using the body prop, before working under it.
4. Do not “race” the engine when unloading.
5. Do not load the hoist beyond its capacity.
6. **DO NOT** tamper with the hydraulic relief valve. This will void the warranty. It can cause severe damage to the hoist and cylinder.
7. Never leave the PTO in gear while transporting. It could ruin the hydraulic pump, the PTO or the transmission.
8. Check all bolts and fittings regularly. Keep them tight.

TABLE OF CONTENTS

Purchase Record	1
Foreword	1
Operation and Use	2
Some Do's and Don't's	2
Table of Contents	3
Locate Cylinder Mount and Rear Hinge – M63 Series	4
Locate Cylinder Mount and Rear Hinge – M74 Series	5–6
Install Cylinder Mount	7
Install Rear Hinge	8
Install Body/Hoist Assembly	8
Mount Pump—Standard	9
Reversing Pump Rotation	9
Optional Remote Mount Kit	10
Install Drive Shaft for Remote Mount Kit	10
Mount Reservoir – M53, M63 Series & M74 Optional	11
Mount Doghouse Reservoir – M74 Series	12
Install Valve Control	12
Install Cylinder Hoses – Double—Acting	13
Install Cylinder Hose – Single—Acting	13
Install Return and Suction Hoses	13
Add Hydraulic Oil	14
Mount Body – M53 & M63 Series	15
Mount Body – M74 Series	15
Align Hoist Cylinder and Weld Rear Hinge	16
Install Body Guides	16
Install Body Props	17
Bleed Telescopic Cylinder	18
Install Cab Protector	18
Install Grease Zerks and Lubricate	18
Install Lights, Reflectors and Decals	19
Parts Lists and Diagrams	20–25

INSTALLATION INSTRUCTIONS

LOCATE CYLINDER MOUNT AND REAR HINGE – M53 & M63 SERIES

The telescopic cylinder mount and the rear hinge must be located relative to each other according to the following chart. The chart shows the hoist model, recommended body length and CA or CT, the overhang, dump angle and mounting distance. The mounting distance is measured from the center of the rear hinge pin to the front of the body lift assembly.

The rear hinge must be located as close as possible behind the rear spring hanger. For single axle trucks this will be approximately 33 inches behind the rear axle and must never be more than 36 inches. For tandem axle trucks, this will be approximately 45 inches behind the center of the tandem, and must never be more than 50 inches. The telescopic cylinder mount should be located so there is at least 3” of clearance between the front of the body lift assembly and the back of the cab. See Fig. 1. (The lower cylinder mount extends past the front of the body 1 1/4”.)

HOIST MODEL	BODY LENGTH	CA or CT DIMENSIONS	OVERHANG	DUMP ANGLE	“D” DIM
M5390	10’	84”CA	6”	49 °	114”
M5399	11’	96”CA	6”	51 °	120”
M53117	12’	102”CA or 96”CT	6”	55 °	132”
	13’	108”CT	12”	50 °	144”
M63138	14’	114”CT	12”	55 °	156”
	15’	126”CT	12”	50 °	168”
M63153	16’	138”CT	12”	52 °	180”
	17’	150”CT	12”	49 °	192”

- NOTE: 1. The “CA or CT Dimensions” and “Overhang” columns assume cab clearance of 3” and a rear hinge dimension of 33” for single axle trucks and 45” for tandem axle trucks.
2. The front edge of the lift plates is even with the front of the body.

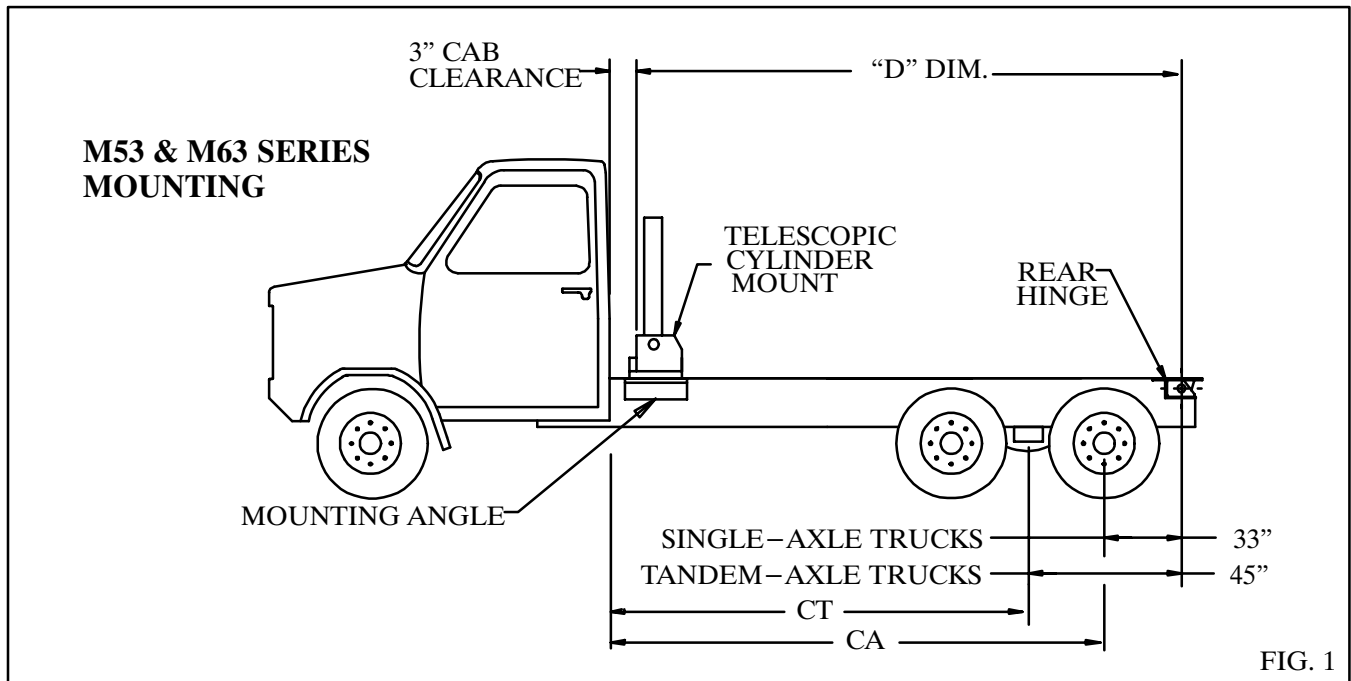

FIG. 1

LOCATE CYLINDER MOUNT AND REAR HINGE – M74 SERIES

The telescopic cylinder hoist mount and the rear hinge must be located relative to each other according to the following charts. The charts show the the hoist model, the recommended body length and CT, the overhang, dump angle and mounting distance. The mounting distance or “D” dimension is measured from the center of the rear hinge pin to the center of the lift cylinder.

The rear hinge must be located as close as possible behind the rear spring hanger. For tandem axle trucks, this will be approximately 45 inches behind the center of the tandem, and must never be more than 50 inches.

In the ‘set-back’ mounting, the cylinder is set back from the front of the body to allow space for a reservoir; the doghouse is fairly large to cover the hoist cylinder and the reservoir. In the ‘flush’ mounting, the front of the telescopic cylinder mount is even with the inside front of the body. For ‘bail’ mounting, the cylinder is completely in front of the body so there is no doghouse in the body.

For set-back mounting, the hoist mount should be located so there is at least 3” of clearance between the reservoir and the back of the cab. (See Fig. 2.) For flush or bail mounting, the hoist mount should be located so there is at least 3” of clearance between it and the back of the cab. (See Fig. 3.)

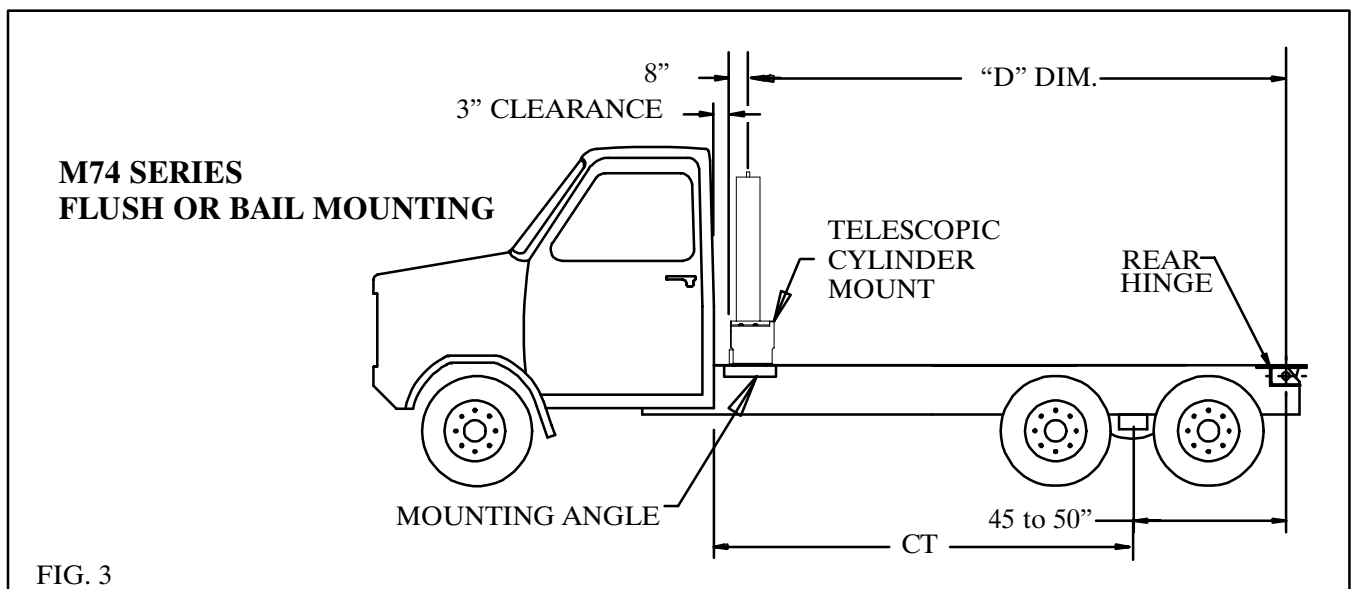
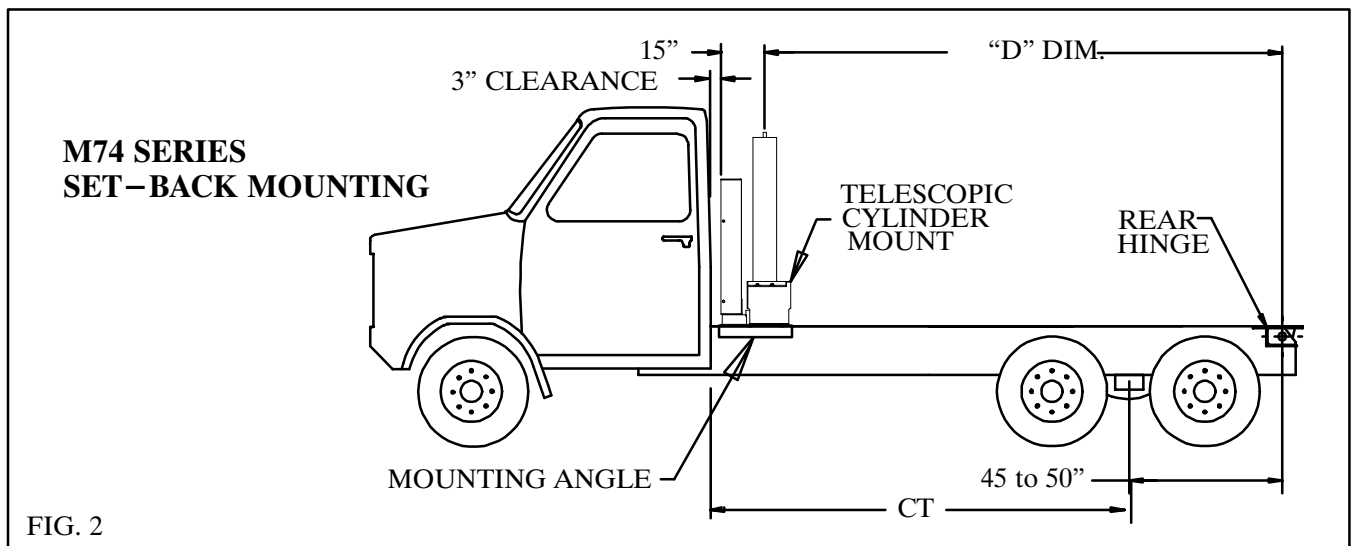

M74 SERIES – SET BACK MOUNTING					
HOIST MODEL	BODY LENGTH	CT DIMENSIONS	OVERHANG	DUMP ANGLE	“D” DIM
M74161	16'	138”CT	12”	59°	165”
	17'	150”CT	12”	55°	177”
M74181	18'	162”CT	12”	58°	189”
	19'	174”CT	12”	54°	201”
M74201	20'	186”CT	12”	56°	213”
	21'	198”CT	12”	53°	225”

NOTE: The “CT dimensions” and “Overhang” columns assume a clearance of 3” between the back of the cab and the front of the body and a rear hinge dimension of 45”.

M74 SERIES – FLUSH MOUNTING					
HOIST MODEL	BODY LENGTH	CT DIMENSIONS	OVERHANG	DUMP ANGLE	“D” DIM
M74161	16'	138”CT	12”	56°	174”
	17'	150”CT	12”	52°	186”
M74181	18'	162”CT	12”	55°	198”
	19'	174”CT	12”	51°	210”
M74201	20'	186”CT	12”	54°	222”
	21'	198”CT	12”	51°	234”

NOTE: The “CT dimensions” and “Overhang” columns assume a clearance of 3” between the back of the cab and the front of the body and a rear hinge dimension of 45”.

M74 SERIES – BAIL MOUNTING					
HOIST MODEL	BODY LENGTH	CT DIMENSIONS	OVERHANG	DUMP ANGLE	“D” DIM
M74161	15'	138”CT	12”	55°	177”
	16'	150”CT	12”	51°	189”
M74181	17'	162”CT	12”	54°	201”
	18'	174”CT	12”	50°	213”
M74201	19'	186”CT	12”	53°	225”
	20'	198”CT	12”	50°	237”

NOTE: The “CT dimensions” and “Overhang” columns assume a clearance of 3” between the back of the cab and the front of the upper hoist mount and a rear hinge dimension of 48”.

INSTALL CYLINDER MOUNT

Make sure the cylinder mount is correctly located (as determined by the previous instructions), centered, and square with the truck frame. If there are rivets or frame bolts in the way, holes can be drilled in the cylinder mount to allow it to sit flat on the truck frame. The mounting angles do not have pre-drilled holes in them to allow the use existing holes in the truck frame. Clamp the mounting angles against the outside of the truck frame and against the bottom of the cylinder mount. (See Fig. 5.) Mark the location of the holes in the truck frame on the mounting angles. Remove the mounting angles and drill the holes in the locations marked.

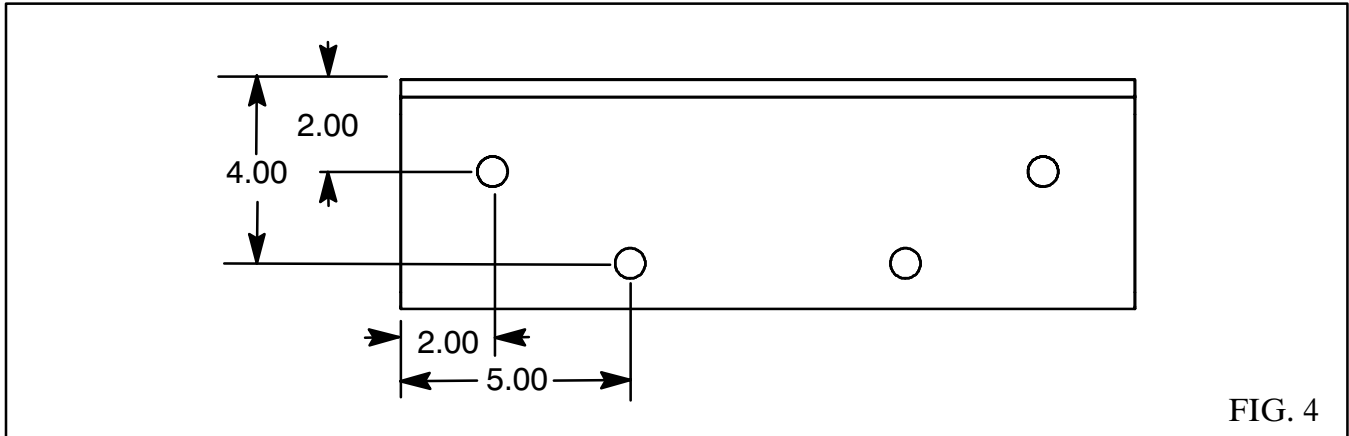

Bolt the mounting angles to the truck frame using the existing holes. The mounting angles must be attached to the truck frame with a minimum of four (4) 5/8" grade 8 cap screws. If the existing holes are not evenly spread over the whole length, additional holes should be drilled, spaced approximately as shown in Fig. 4.

CAUTION: BE CAREFUL OF BRAKELINES, WIRING, ETC. INSIDE THE TRUCK FRAME WHEN DRILLING THE TRUCK FRAME.

Drill 21/32" diameter holes in the mounting angles and truck frame and bolt the mounting angles in place using 5/8 x 2 cap screws (grade 8) and hex lock nuts. Tighten the cap screws to 180 to 190 lb-ft. Securely weld the cylinder mount to the mounting angles. *DO NOT weld the cylinder mount to the truck frame.* (See Fig. 5.)

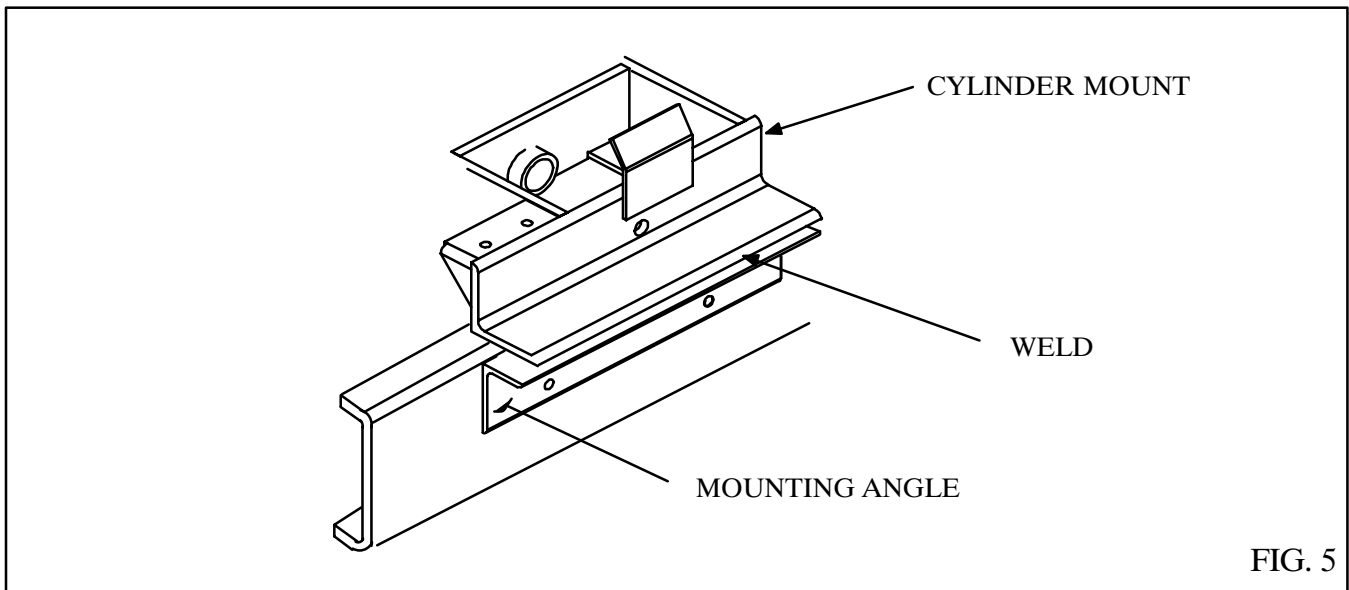

INSTALL REAR HINGE

If the front of the body longbeams are notched for the hoist, mount the rear hinge as shown in Fig.6, style A. If the front of longbeams are notched, use Fig.6, style B. Notch the truck frame as shown in Fig. 6. Place the rear hinge on the truck frame. Make sure the rear hinge is correctly located, centered and square with the truck frame and the telescopic cylinder mount. Securely weld the rear hinge to the truck frame. Box the end of the truck frame with 1/4" thick plate (not supplied) and weld all around to the truck frame and rear hinge angle. Place the gussets in the corners formed by the truck frame rail and the rear hinge frame angle. Raise the front end of the gusset so it touches the top flange of the truck frame rail. Be sure that the gusset does not interfere with the rear hinge operation. Securely weld the gussets to the rear hinge, the truck frame rail and the top flange of the truck frame rail.

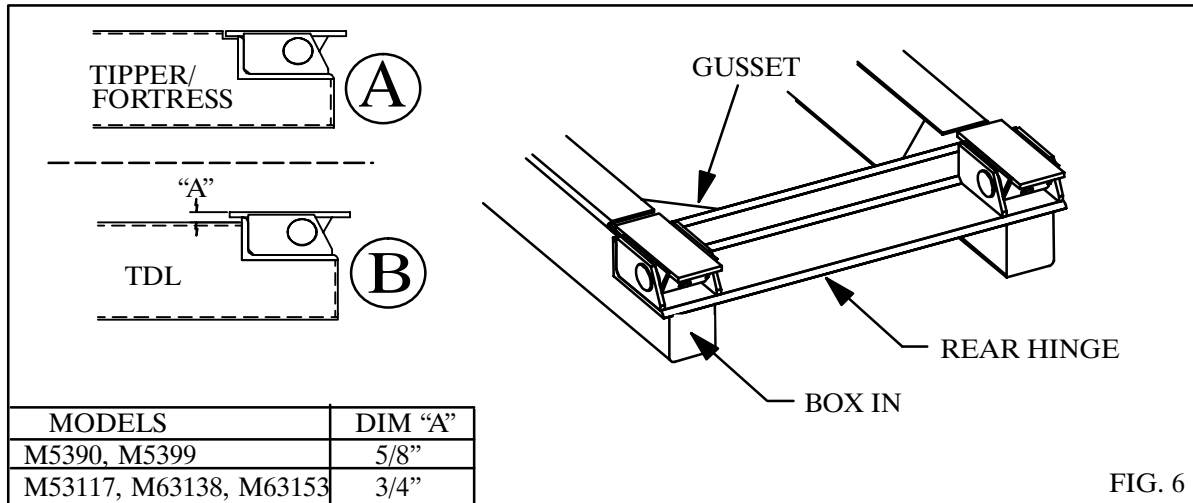

FIG. 6

NOTE: IT IS VERY IMPORTANT TO INSTALL THESE GUSSETS TO SECURELY MOUNT THE REAR HINGE TO THE TRUCK FRAME.

NOTE: If there are rivets on the top flange of the truck frame run a spacer the full length of the truck frame before mounting the telescopic cylinder mount or the rear hinge.

INSTALL BODY/HOIST ASSEMBLY

On some standard and custom bodies, the hoist is installed at the factory. This requires altering the installation procedures. Before placing the body/hoist assembly on the truck, install a male ORB x female NPT 90° swivel adapter in the power up port on the cylinder. For M53 and M63 double-acting cylinders, install a 3/4 ORB male x 3/8 NPT female 90° swivel adapter in the power down port. For M74 series double-acting cylinders, install a 7/8 ORB male x 1/2 NPT female 90° swivel adapter in the power down port.

Place the body/hoist assembly on the truck frame with 3" of cab clearance. Make sure the body and hoist assembly is correctly located, centered and square with the truck frame. Refer to the INSTALL CYLINDER MOUNT section above for installing the mounting angles.

Rivet strips (not supplied) may be installed for supporting the longbeams of Crysteel TDL dump bodies.

MOUNT PUMP – STANDARD

The standard pump/valve is intended to be mounted directly to a two–gear PTO with a direct mount flange. This saves time and effort and simplifies the installation. The pump has an SAE ‘B’ 4–bolt flange and a 13 tooth splined shaft. *NOTE: This pump will mount directly to Chelsea’s output type “XK” or Muncie’s output type “D”. Crysteel recommends a PTO ratio of 100 to 120%. This assures a minimum pump operating speed of 600 RPM.* The pump is assembled with a counter–clockwise rotation when looking at the shaft end of the pump.

IMPORTANT: Before mounting the pump/valve, check the rotation of the PTO and make sure it matches the rotation of the pump. If it is opposite, the pump rotation will have to be reversed. To reverse the pump rotation, follow the pump reversing procedure below. Make sure the pump has plenty of clearance and that the hoses are kept clear of hot mufflers and exhaust pipes.

IMPORTANT: The C102D pump/valve supplied for the T63113 through T74191 can be mounted directly to a PTO but MUST be supported externally to the transmission. Long mounting studs and extra nuts are provided with each unit for this purpose.

REVERSING PUMP ROTATION

The pump is assembled with a counter–clockwise rotation when looking at the shaft end of the pump. (Looking at the shaft end of the pump with the drive shaft on top and the idler gear on the bottom, the valve spool will be on the left side. See Fig. 7.) If the pump needs to rotate in the opposite direction, then follow these steps to reverse the pump:

1. Remove the four 9/16–12 capscrews holding the pump together.
2. CAREFULLY remove the valve body assembly from the pump.
3. CAREFULLY remove the gear housing. Rotate the housing 180° and replace it. The drive shaft gear bore becomes the idler gear bore.
4. Rotate the valve body 180° from its original position and replace it.
5. Replace the four 9/16–12 capscrews and torque to 2400 in–lbs.
6. To verify that the pump is now assembled for clockwise rotation, look at the shaft end of the pump with the drive shaft on the top and the idler gear on the bottom, the valve spool will be on the right side. (See Fig. 8.)
7. Fill the suction port with hydraulic oil and rotate shaft to fill the gears with oil.

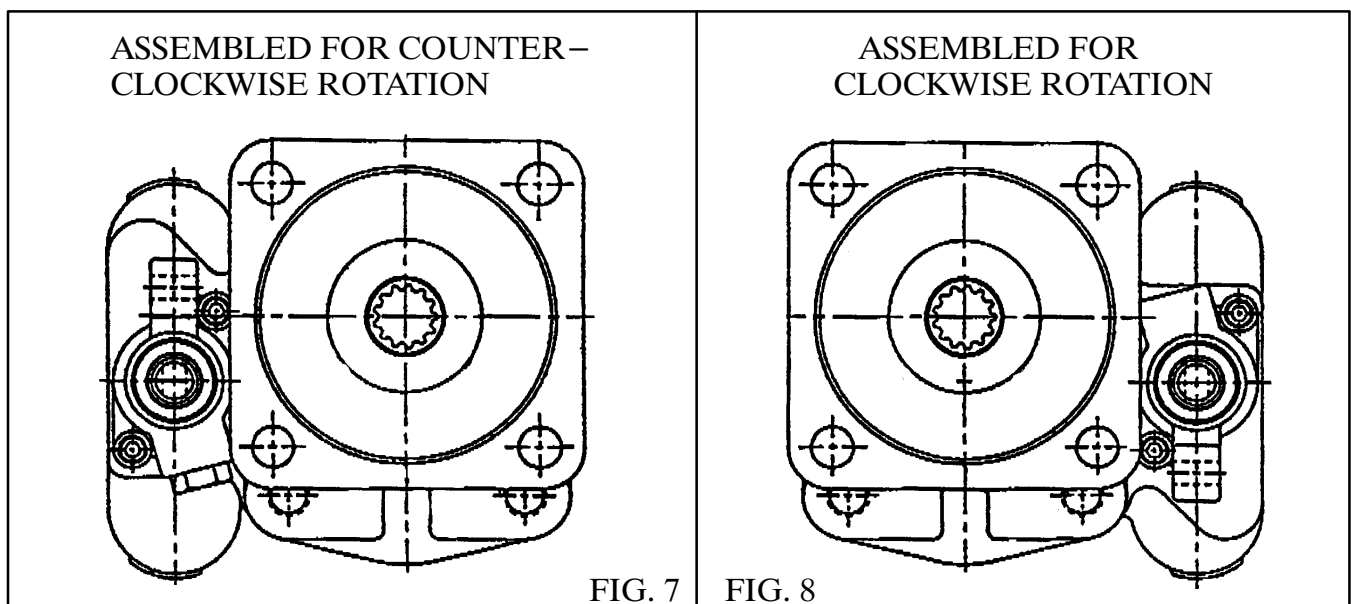

OPTIONAL REMOTE MOUNT KIT

If the pump/valve cannot be mounted directly to the PTO, a remote mount kit is available for mounting the pump/valve to the truck frame. This kit consists of a mounting bracket, U-Joints and drive shaft. Determine which side of the truck frame to mount the pump/valve (same as the PTO opening on the transmission). **IMPORTANT:** Before mounting the pump/valve, check the rotation of the PTO and make sure it matches the rotation of the pump. If it is opposite, the pump rotation will have to be reversed. To reverse the pump rotation, follow the pump rotation reversing procedure above.

Bolt the pump/valve to the pump mounting bracket using 1/2 x 2 grade 8 cap screws and hex lock nuts, tightening to 90 to 100 lb-ft. Clamp the pump mounting bracket to the truck frame so the pump/valve is just behind the PTO. Check that the drive shaft is long enough and doesn't exceed 15° in angularity. Check for sufficient clearance around the pump/valve. Reposition the pump/valve for the best location. Be sure the PTO shaft and the pump shaft are parallel. This improves the life expectancy of the U-Joints. In some cases it may be necessary to rework the exhaust system for sufficient clearance around the pump/valve. (See Fig. 9.)

CAUTION: BE CAREFUL OF BRAKELINES, WIRING, ETC. INSIDE THE TRUCK FRAME WHEN DRILLING THE TRUCK FRAME.

After locating the pump/valve, drill 17/32" holes through the truck frame and bolt the pump mounting bracket in place using 1/2 x 2 grade 8 cap screws and hex lock nuts, tightening to 90 to 100 lb-ft.

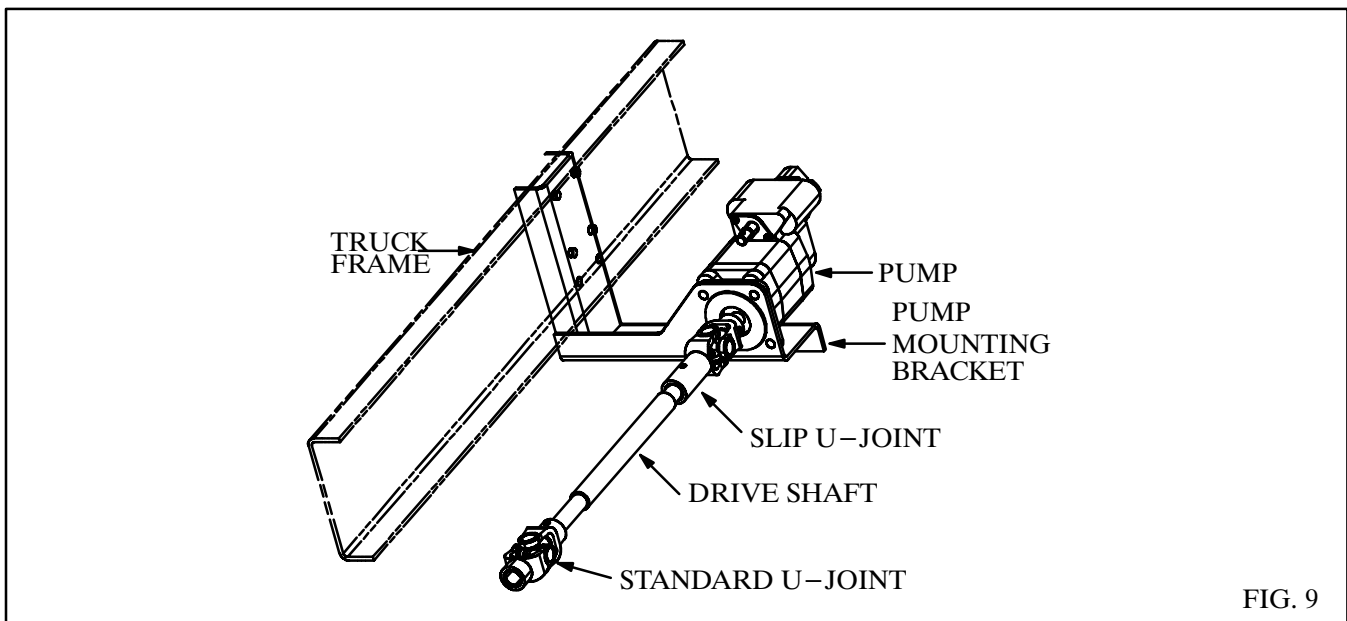

INSTALL DRIVESHAFT FOR OPTIONAL REMOTE MOUNT PUMP

Install the long U-joint on the pump shaft and the short U-joint on the PTO shaft so that the inner edge of the hub of each is flush with the end of the shaft. **DO NOT TIGHTEN THE SET SCREWS.** Measure the distance from the inner edge of the hub of one U-joint to the inner edge of the hub of the other U-joint. This is the length the finished drive shaft assembly needs to be. The short shaft will increase the length of the drive shaft 5 inches after the short drive shaft and the drive shaft assembly are welded together. (See Fig. 10.) Cut the drive shaft to the proper length and deburr the inside of the tube. Insert the short drive shaft into the drive shaft assembly and **ROTATE UNTIL BOTH KEYWAYS ARE IN LINE.** Weld the short drive shaft and the driveshaft assembly together. Install the driveshaft and tighten all set screws. Retighten the set screws and secure them with a safety wire.

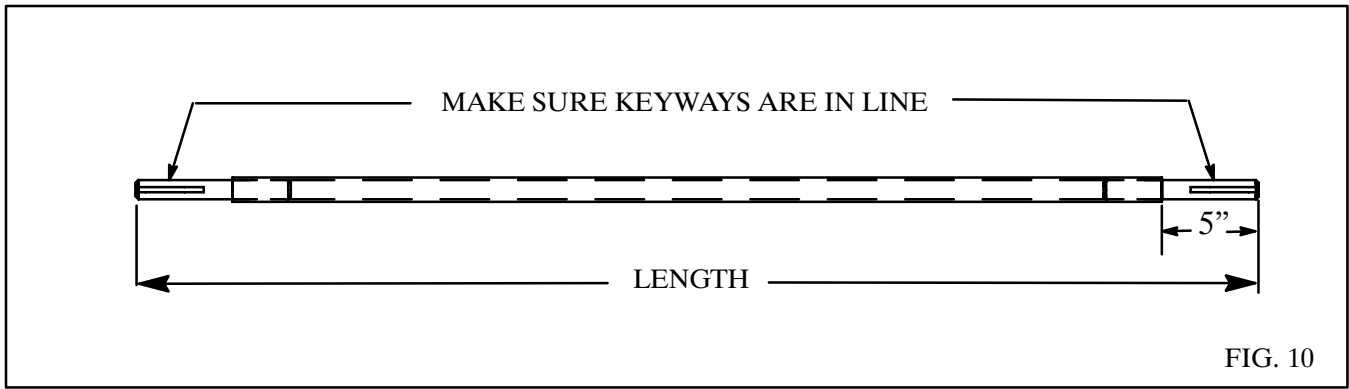

MOUNT RESERVOIR – M53, M63 SERIES & M74 SERIES OPTIONAL

Determine on which side of the truck to mount to mount the reservoir. There are four ports on the reservoir – a fill port on the top, a 2” NPT suction port on the bottom, a 1 1/4” NPT return port near the bottom on one side and one smaller port near the top on one side for a sight glass. Clamp the reservoir mounting brackets to the sides of the reservoir and place the reservoir against the outside of the truck frame. (See Fig. 11.) Mark the truck frame for drilling using the mounting brackets as guides.

CAUTION: BE CAREFUL OF BRAKELINES, WIRING, ETC. INSIDE THE TRUCK FRAME WHEN DRILLING THE TRUCK FRAME.

Drill 17/32” holes in the truck frame and bolt the mounting brackets in place using 1/2 x 2 grade 8 cap screws and hex lock nuts, tightening to 90 to 100 lb–ft. Securely weld the reservoir to the reservoir mounting brackets. Install the sight glass in the port provided.

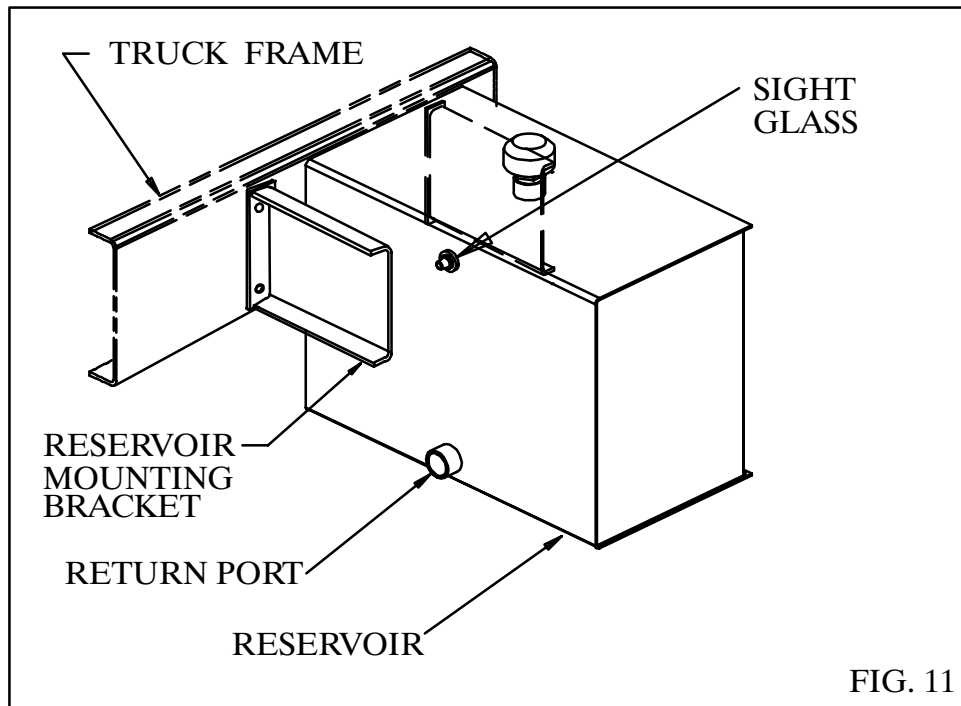

INSTALL DOGHOUSE RESERVOIR – M74 SERIES

The doghouse reservoir is intended to be bolted to the telescopic cylinder mount between the hoist cylinder and the cab of the truck. Place the reservoir on the reservoir mounting brackets and bolt in place using 1/2 x 2 grade 8 cap screws, flat washers and hex lock nuts, tightening to 90 to 100 lb–ft. Install 90° tubing fittings in the ports on the side of the reservoir and install the plastic tubing between the tube fittings. (See Fig. 12.)

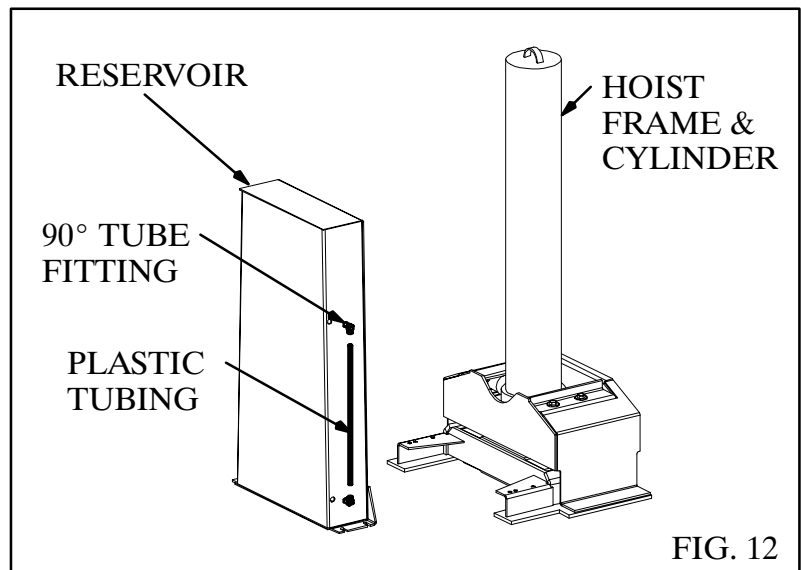

FIG. 12

INSTALL VALVE CONTROL

Place the control pedestal assembly on the floor of the cab in a convenient location next to the drivers seat. Mark the floor using the pedestal as a template and drill 5/16 inch holes for the mounting screws and a 3/4 inch hole for the control cable. (Check below the floor for obstructions and cable routing before drilling.)

Insert the control cable through the hole in the bottom of the pedestal and attach it to the valve control. Bolt the valve control to the pedestal using 1/4 x 1/2 machine screws. Install the cover on the side of the pedestal using #10 x 3/8 self tapping screws. Mount the pedestal to the floor using 5/16 x 1/2 cap screws and hex lock nuts. Connect the other end of the cable to the control valve using the parts and instructions in the valve connection kit. (See Fig. 13.) **NOTE:** *The two spool seal retaining plates on the 'G' series pump/valves must remain installed on the pump/valve. If the are removed, oil can be pumped past the spool into the control cable and into the cab of the truck.*

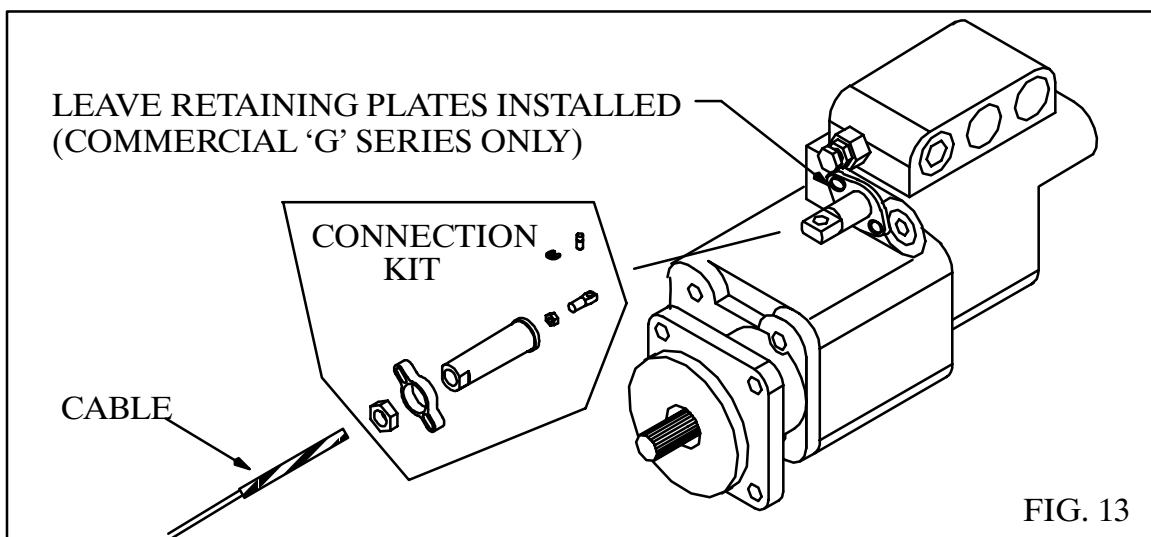

FIG. 13

INSTALL CYLINDER HOSES – DOUBLE ACTING

For M53 series, install a 1 1/16 ORB male x 3/4 NPT female 90° swivel adapter in the power-up port on the cylinder. For M63 series, install a 1 1/16 ORB male x 1 NPT female 90° swivel adapter in the power-up port on the cylinder. Install a 3/4 ORB male x 3/8 NPT female 90° swivel adapter in the power-down port.

For M53 series, install a 1 1/16 ORB x 3/4 NPT 90° swivel adapter in the B (power up) port of the control valve. For M63 series, install a 1 1/16 ORB x 1 NPT 90° swivel adapter in the B (power up) port of the control valve. Install a 1 1/16 ORB x 3/4 ORB extension and a 3/4 ORB x 3/8 NPT 90° swivel adapter in the A (power down) port. Using a 60" long hose, connect the B port on the control valve to the power up port on the cylinder. Using a 60" long 3/8" I.D. hose, connect the A port to the power down port. This will raise the body when the valve control lever is pulled back and lower the body when the lever is pushed forward.

INSTALL CYLINDER HOSE – SINGLE ACTING

For M53 series, install a 1 1/16 ORB male x 3/4 NPT female 90° swivel adapter in the port on the cylinder. Install a 1 1/16 ORB x 3/4 NPT swivel adapter in the work port of the control valve. Using a 60" long hose, connect the work port of the control valve to the port on the telescopic cylinder.

For M63 and M74 series, install a 1 5/16 ORB male x 1 NPT female 90° swivel adapter in the port on the cylinder. Using a 60" long hose, connect the work port of the control valve to the port on the telescopic cylinder.

INSTALL RETURN AND SUCTION HOSES

A return line hose must be installed for long pump life. A suction port sleeve has been installed in the suction port on the pump. (See Fig. 14.) This sleeve prevents the oil from recirculating inside the pump/valve and directs the oil flow out the return port. Operating this pump/valve without installing the return line will cause the pump/valve to fail.

For M53 series, install a 1 1/4 x 1 hex reducing bushing in the return port on the reservoir. Remove the plug from the return port on the control valve and install a swivel adapter in its place. Install a 72" long hose from the return port on the pump to the return port on the reservoir.

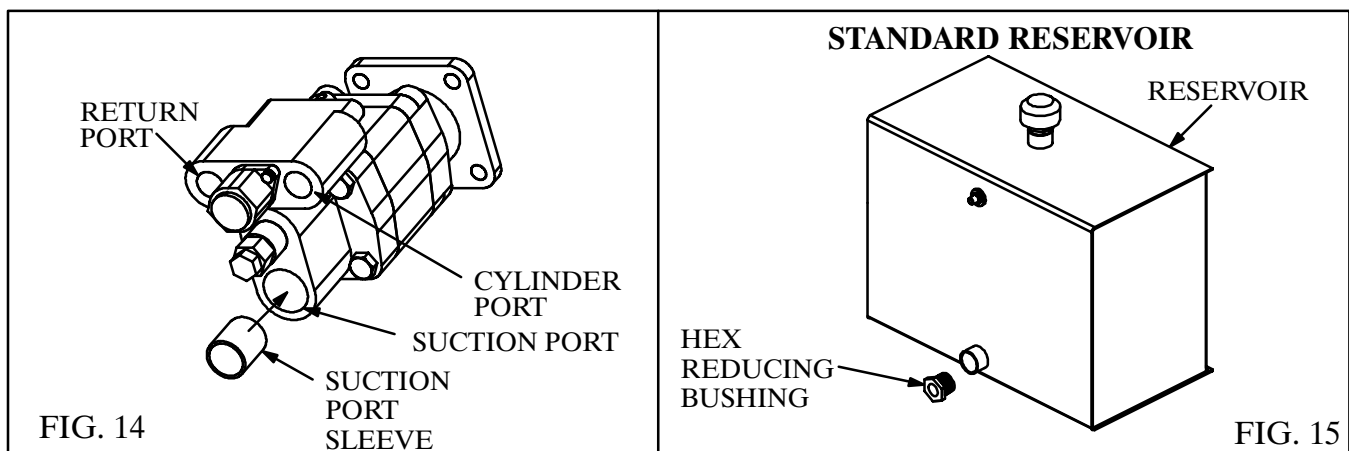

Install the 2" NPT x 1 1/2" hose barb in the suction port on the bottom of the frame-mounted reservoir, the 1 1/2" NPT x 1 1/2" hose barb for the doghouse reservoir, and the 1 1/4" NPT x 1 1/2" hose barb in the suction port on the back of the pump/valve. Connect a 1 1/2" I.D. suction hose from the reservoir to the pump and secure it with hose clamps.

ADD HYDRAULIC OIL

Use a quality hydraulic fluid of 150 SSU @ 100°F which contains corrosion and oxidation inhibitors and a foam depressant. This is approximately the equivalent of SAE 10W or lighter weight oil. Initially fill the reservoir with the quantities given below. After bleeding the air from the cylinder, refill the reservoir to the sight glass level or top of oil level tube with the body down. **DO NOT OVERFILL THE RESERVOIR!**

KEEP THE OIL CLEAN! USE CLEAN CONTAINERS, FUNNELS AND OTHER EQUIPMENT!

HOIST MODEL	SIDE MOUNTED	INITIAL FILL AMOUNT	DOGHOUSE RESERVOIR	INITIAL FILL AMOUNT
M5390	16 Gal.	12 Gal.	Not Available	
M5399	16 Gal.	12 Gal.	Not Available	
M53117	23 Gal.	16 Gal.	Not Available	
M63138	28 Gal.	21 Gal.	Not Available	
M63153	28 Gal.	21 Gal.	Not Available	
M74161	40 Gal.	30 Gal.	30 Gal.	20 Gal.
M74181	40 Gal.	30 Gal.	30 Gal.	20 Gal.
M74201	40 Gal.	30 Gal.	30 Gal.	20 Gal.

NOTE: If the pump does not pump oil, pressurize the reservoir and engage the pump with the engine at slow idle. Once the pump is working, release the pressure and install the breather cap.

With normal use and working conditions the hydraulic oil should be changed annually. The breather cap should be cleaned every time the hydraulic oil is changed. With heavy use or very dusty working conditions the hydraulic oil should be changed more often.

MOUNT BODY – M53 & M63 SERIES

Place the body on the truck with 3” cab clearance for M53 and M63 hoists. Slide the body back until the front panel contacts the upper lift of the cylinder mount. Securely weld the body longbeams to the outside edge of the upper lift of the telescopic cylinder mount. (See Fig. 16.)

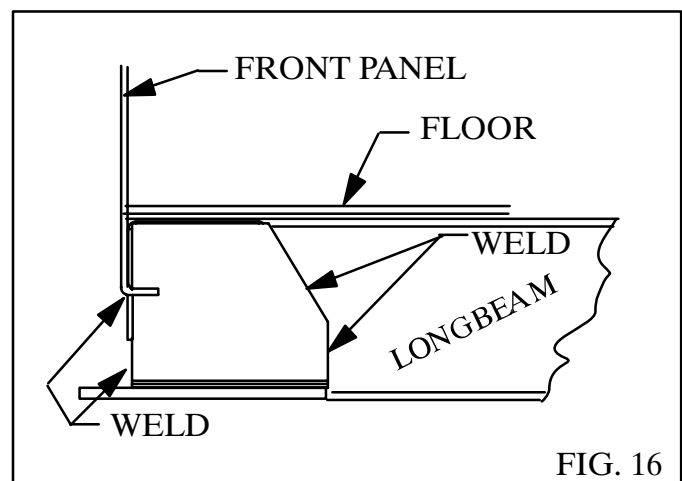

FIG. 16

After the body props have been installed, raise the body to rest on the props. Finish welding the upper lift of the telescopic cylinder mount to the inside of the body longbeams. Securely weld the upper lift to the body longbeams the full height of the upper lift on both the front and back sides of the upper lift. Also weld the bottom edge of the front panel to the upper lift. (See Fig. 16.)

MOUNT BODY – M74 SERIES

For 'set-back' mounting, place the body on the truck with 3" of cab clearance. Slide the body back so the front of the body and the front of the reservoir are even. (See Fig. 18.) Securely weld the body longbeams to the outside edge of the upper lift of the telescopic cylinder mount.

For 'flush' mounting, place the body on the truck with 3" of cab clearance. Slide the body back until the front panel contacts the upper lift of the cylinder mount. (See Fig. 18.) Securely weld the body longbeams to the outside edge of the upper lift of the telescopic cylinder mount.

For 'bail' mounting, place the body on the truck and line up the front of the longbeams and the front of the upper lift. (See Fig. 18.) Securely weld the body longbeams to the outside edge of the upper lift of the telescopic cylinder mount.

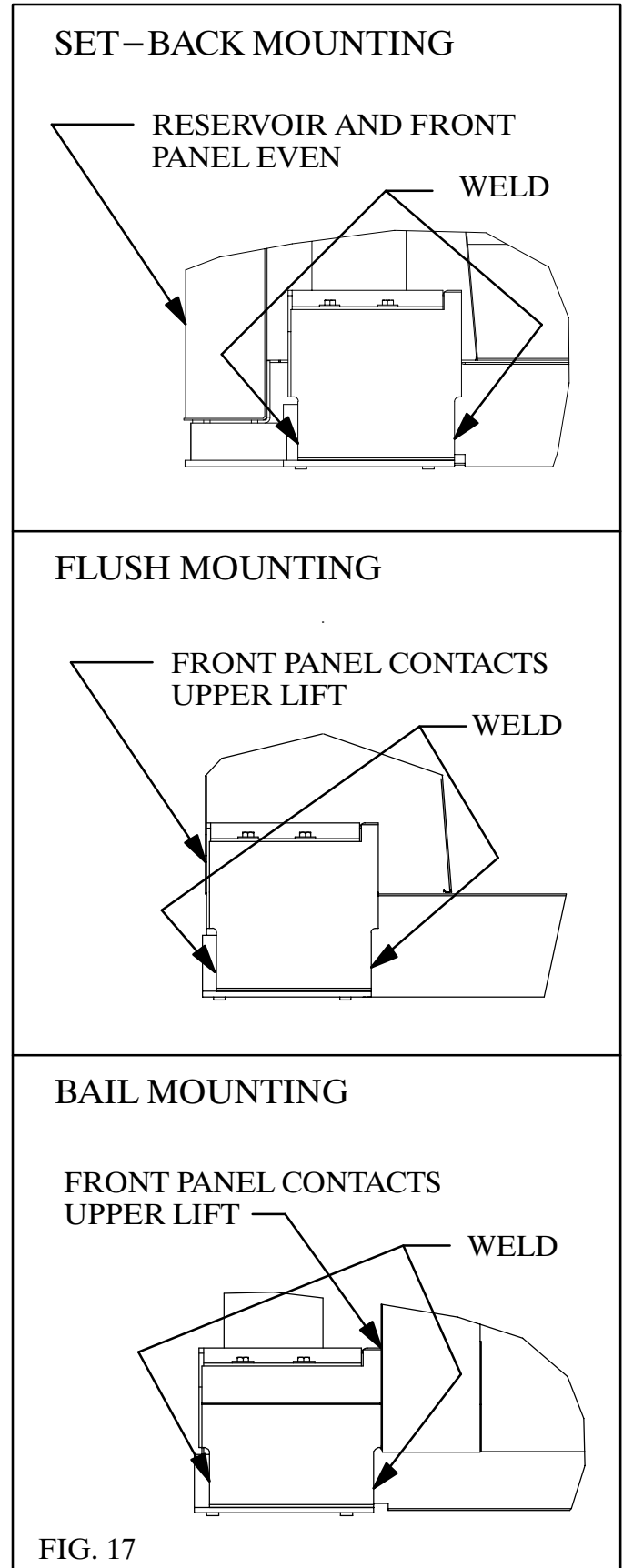

ALIGN HOIST CYLINDER AND WELD REAR HINGE

The entire body and body lift assembly can now be moved slightly forward or rearward to align the cylinder in the doghouse. Make certain that the cylinder is vertical and is not leaning to the front or to the rear. Weld the body longbeams very securely to the rear hinge plates. (See Fig. 18.)

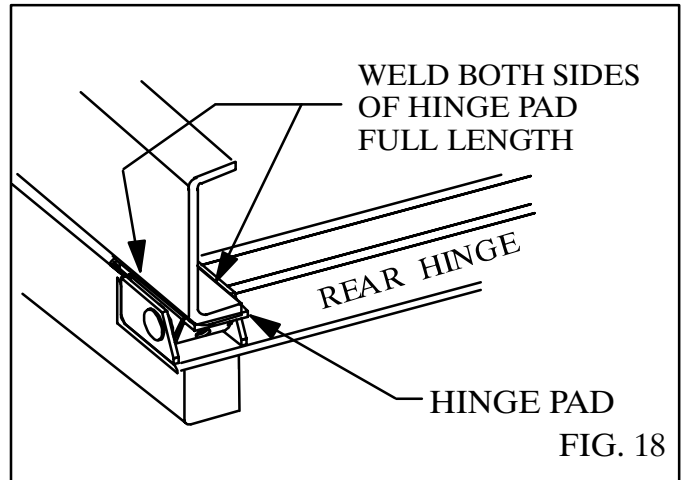

DO NOT WORK UNDER A RAISED BODY UNLESS THE BODY IS SECURELY BLOCKED OR PROPPED IN THE RAISED POSITION.

For M53, M63 and M74 series models, after the body props have been installed, raise the body to rest on the props. Finish welding the upper lift of the telescopic cylinder mount to the inside of the body longbeams. Securely weld the upper lift to the body longbeams the full height of the upper lift on both the front and back sides of the upper lift. Also weld the bottom edge of the front panel to the upper lift. (See Figs. 16 and 17.)

INSTALL BODY GUIDES

The four body guides supplied with your hoist are of two types. Part number 217503 has an obtuse angle that allows it to match the angle of fabricated longbeams. Position this type as shown in Fig. 19 with wide end down, pushed against the longbeam, and centered over the hoist lower mounting angle. Weld securely to the mounting angles. **DO NOT** use the other body guides with fabricated longbeams.

Part number 201415 body guide is used with channel type longbeam and has a right angle that allows it to be positioned as shown in Fig. 20. Position this guide 1/4" away from the longbeam, centered over the lower mounting angle. Place the 217503 body guide inside of it as shown so that the flat sides of the guides fit together. Weld number 201415 to the lower mounting angle and 217503 to the longbeam.

There should be **NO SIDEPLAY** when the truck body is in the lowered position.

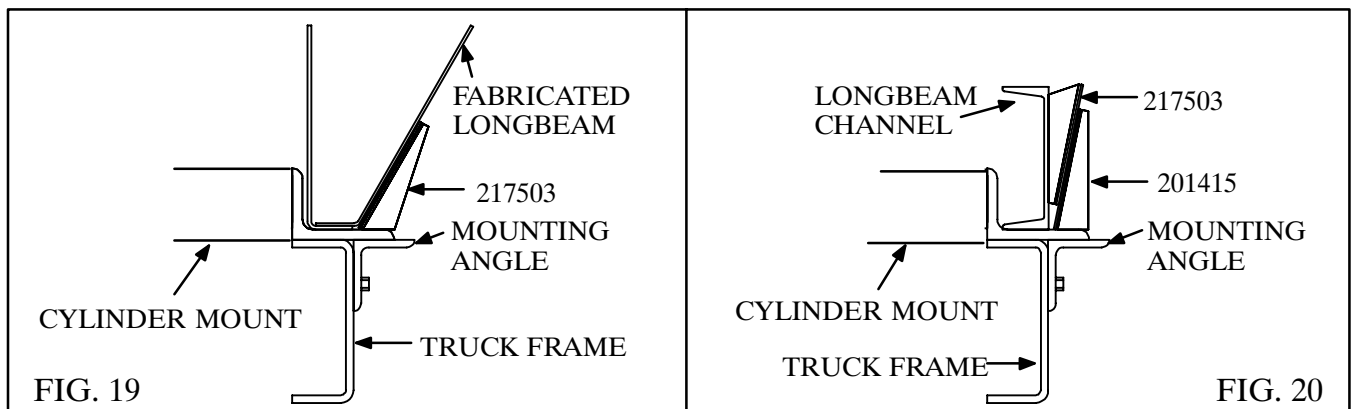

INSTALL BODY PROPS

The body prop is designed and intended to support an EMPTY truck body in the raised position. Use of the body prop permits service to be performed safely beneath a raised body. One body prop is included with Marathon Hoist models M5390 and M5399; two body props (one pair) are included with models M53117 through M74201. Be sure to install each prop on the correct side of the truck as explained below and shown in Fig. 21.

1. Raise the body to a 30° to 35° angle and brace it securely before beginning installation.
2. Assemble the prop arm to the prop pivot mount with a 1/4 x 3 roll pin. Clamp the prop pivot mount against the outside of the truck frame just behind the rear axle. Raise the body prop arm to a free standing position. Place the body prop bracket in the prop arm saddle. Reposition if needed to locate the prop bracket on the longbeam. It may be necessary to raise or lower the body to get the best location for the prop pivot mount. Using the prop pivot mount as a guide, mark the location of holes on the truck frame and drill 17/32 inch holes. Assemble the prop pivot mount to the frame using 1/2 x 2 cap screws, and hex lock nuts, tightening to 90 to 100 lb–ft. Raise the prop arm to a free standing position, place the body prop bracket in the saddle and securely weld the bracket to the longbeam.

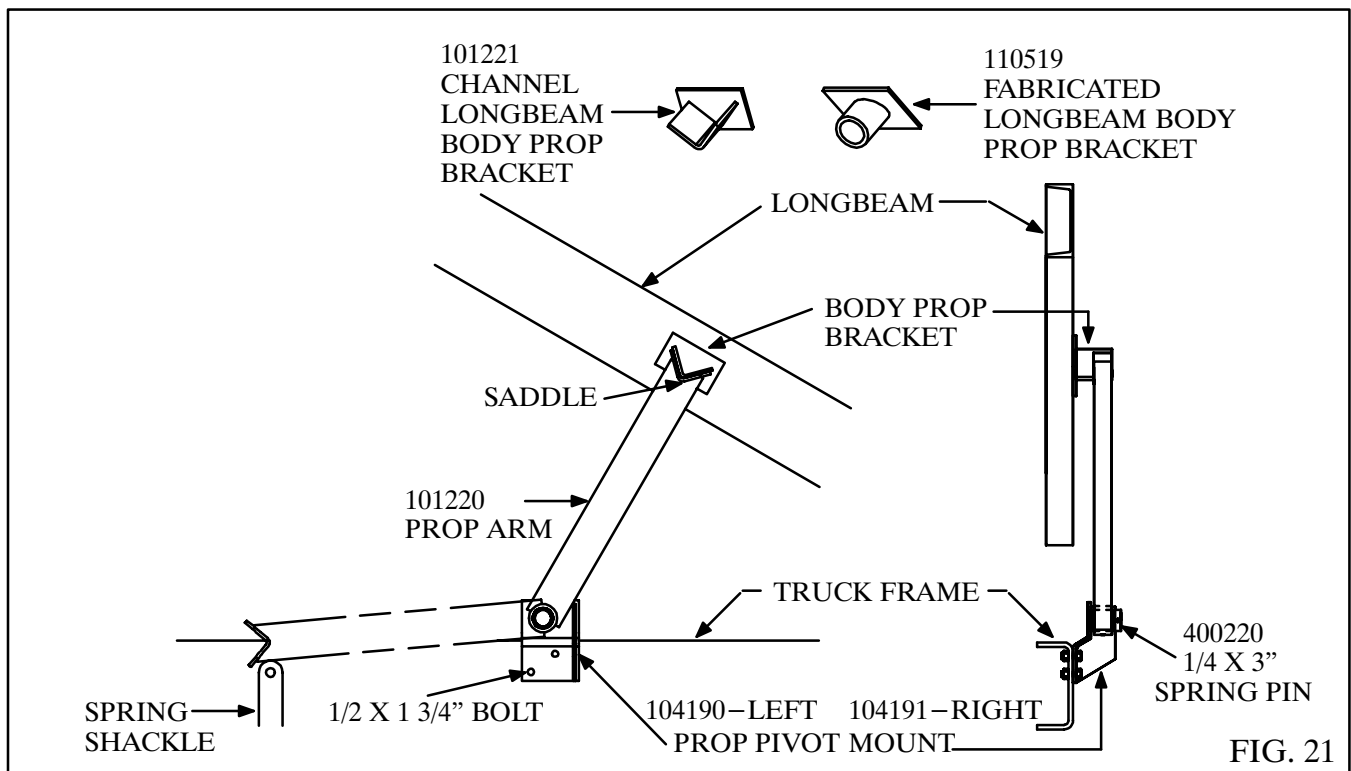

3. When mounting two body props, repeat steps 1 and 2 for the other side. Use the body prop already mounted to assure that both body props hold the body at the same height. The left and right body props should pivot toward the front of the truck in the storage position.
4. To operate the body prop, raise the body to the desired height, shut off all power, raise the prop arm to a free standing position. Lower the body slowly until the body prop bracket contacts the prop arm saddle.
5. To place the body prop in the storage position, raise the body to clear the body prop saddle, lower the body prop to the storage position and lower the body.

BLEED TELESCOPIC CYLINDER

All of the air must be removed from the cylinder for smooth and safe operation of the hoist. All M–Series cylinders are equipped with a self–bleeding feature. To bleed the air from these models, raise and lower the hoist two or three times to remove the air.

After bleeding the cylinder, check the oil level in the reservoir. There should be 2 or more inches of oil in the bottom of the reservoir when the body is raised to its full height. When the body is down, oil should be visible in the sight glass or at the top of the oil level tube.

***DO NOT WORK UNDER A RAISED BODY UNLESS THE BODY IS SECURELY
BLOCKED OR PROPPED IN THE RAISED POSITION.***

INSTALL CAB PROTECTOR

If a cab protector is to be installed on the front of the dump body, it must be notched to fit around the “doghouse”. This is because the cylinder swings forward as the body is raised and severe damage would occur if the cylinder were trapped by the cab protector.

INSTALL GREASE ZERKS AND LUBRICATE

Install grease zerks in the body props. Lubricate all fittings at regular intervals, at least every 150 cycles or every two months. The grease fittings are located as follows:

- A. Body Prop 1 fitting per prop
- B. Rear Hinge 2 fittings
- C. Optional U–Joints 3 fittings

NOTE: The hoist cylinder pivots, both truck mount and body mount, do not require lubrication. These pivot points are equipped with self–lubricating composite bearings that do not need lubrication. If they are ever disassembled (to repair or replace the cylinder), care must be used to avoid damage to the composite bearings.

INSTALL LIGHTS, REFLECTORS AND DECALS

Install the lights and wiring harness. Mount the amber reflectors near the front on the sides. Mount the red reflectors near the rear on the sides and on the tailgate near the sides. Slip the rubber hand grip over the end of the latch control lever. MOUNT DECALS IN THE PROPER PLACES. See Fig. 22 for decal identification and placement.

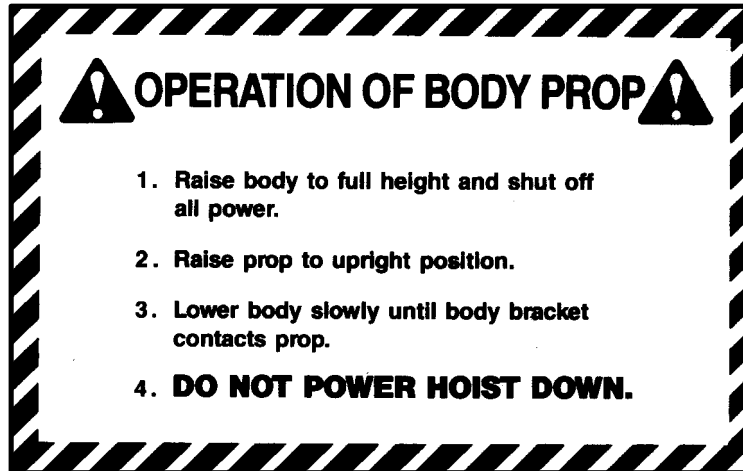

400719—Mount on the body longbeam near the body prop

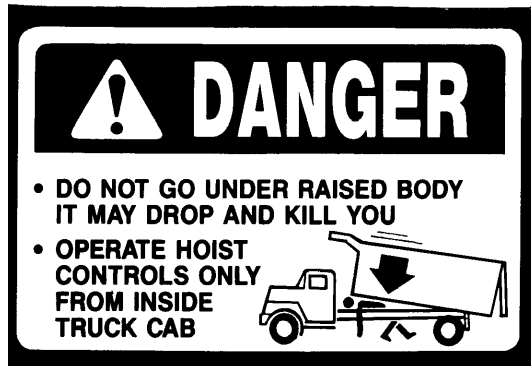

401576—Mount on the outside of the body longbeams near the front of the body (one on each side).



400643—Mount on the longbeam on the drivers side.

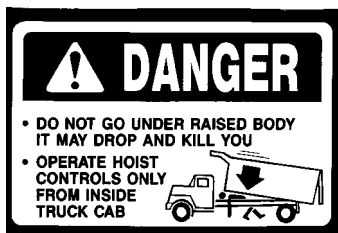

401577—Mount in the cab in a prominent location

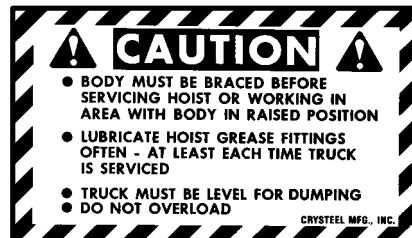

400642—Mount in the cab in a prominent location?



400661—Mount on the body prop arm.

FIG. 22

M53 & M63 SERIES MARATHON HOIST PARTS

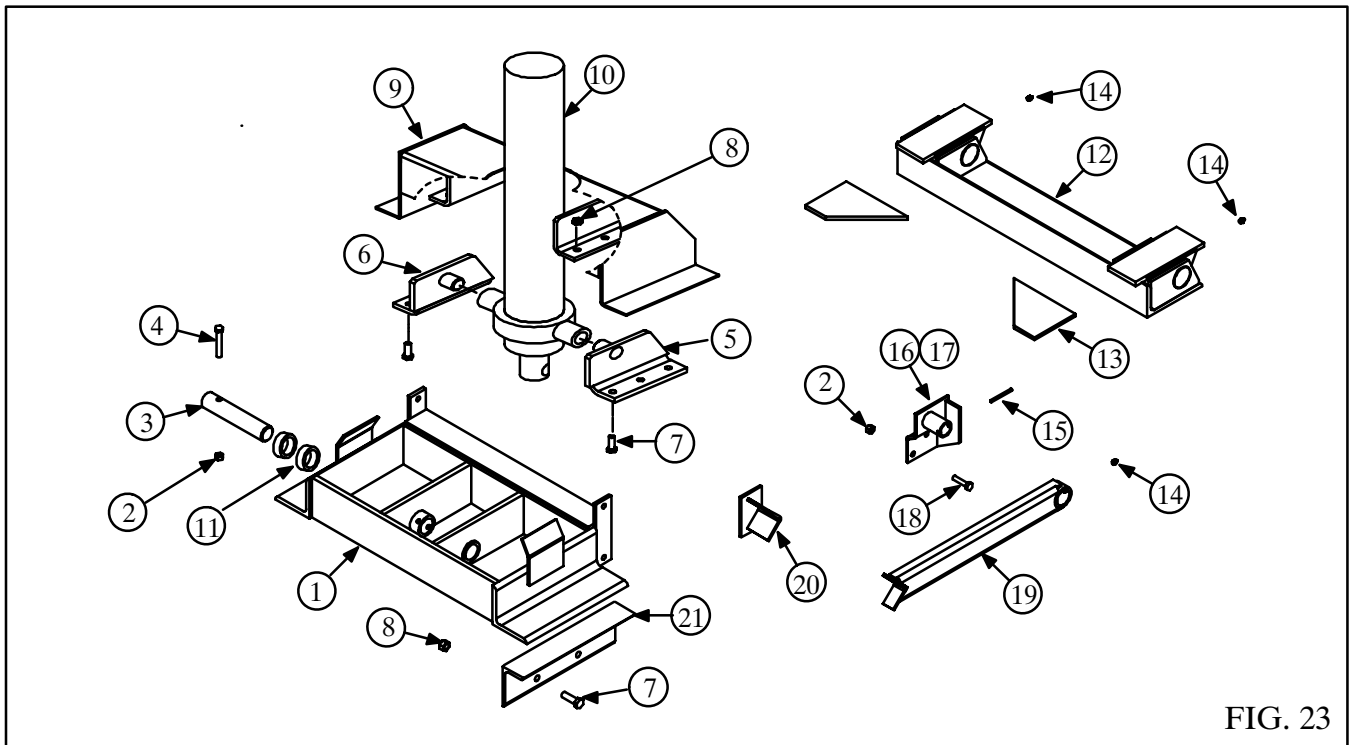

ITEM	DESCRIPTION	M5390	M5399	M53117	M63138	M63153	QTY
1.	Assy Lower Mount	107347	107347	107345	107345	107345	1
2.	Hex Lock Nut 1/2-13	401316	401316	401316	401316	401316	5
3.	Pin Hoist Pivot 8.75" LG	208047	208047	208047	208047	208047	1
4.	Cap Screw 1/2 X 3 1/4 HH	401140	401140	401140	401140	401140	1
5.	Assy Upper Pivot -L	124266	124266	124266	124266	124266	1
6.	Assy Upper Pivot -R	124267	124267	124267	124267	124267	1
7.	Cap Screw 5/8 X 2 HH	402374	402374	402374	402374	402374	14
8.	Hex Lock Nut 5/8-11	401582	401582	401582	401582	401582	14
9.	Assy Upper Lift	124265	124265	124265	124265	124265	1
10.	Assy Cylinder - SA	403656	403657	403658	404902	404903	1
	Assy Cylinder - DA	403122	403123	403124	403125	403126	1
11.	Spacer Lower - M53	208939	208939	208939			2
	Spacer Lower - M63				208938	208938	2
12.	Assy Rear Hinge	106060	106060	107037	107037	107037	1
13.	Gusset Rear Hinge	402339	402339	402339	402339	402339	2
14.	Grease Zerk 1/8 NPT	400103	400103	400103	400103	400103	4
15.	Spring Pin 1/4 X 3	400220	400220	400220	400220	400220	2
16.	Assy Prop Pivot - L	104190	104190	104190	104190	104190	1
17.	Assy Prop Pivot - R	104191	104191	104191	104191	104191	1
18.	Cap Screw 1/2 X 2 HH	400105	400105	400105	400105	400105	4
19.	Assy Body Prop Arm	101220	101220	101220	101220	101220	2
20.	Assy Prop Bracket	125259	125259	125259	125259	125259	2
21.	Angle Mounting - 16"	208059	208059	208059	208059	208059	2
22.	Seal Kit	403153	403153	403153	403154	403154	1

M74 SERIES MARATHON HOIST PARTS

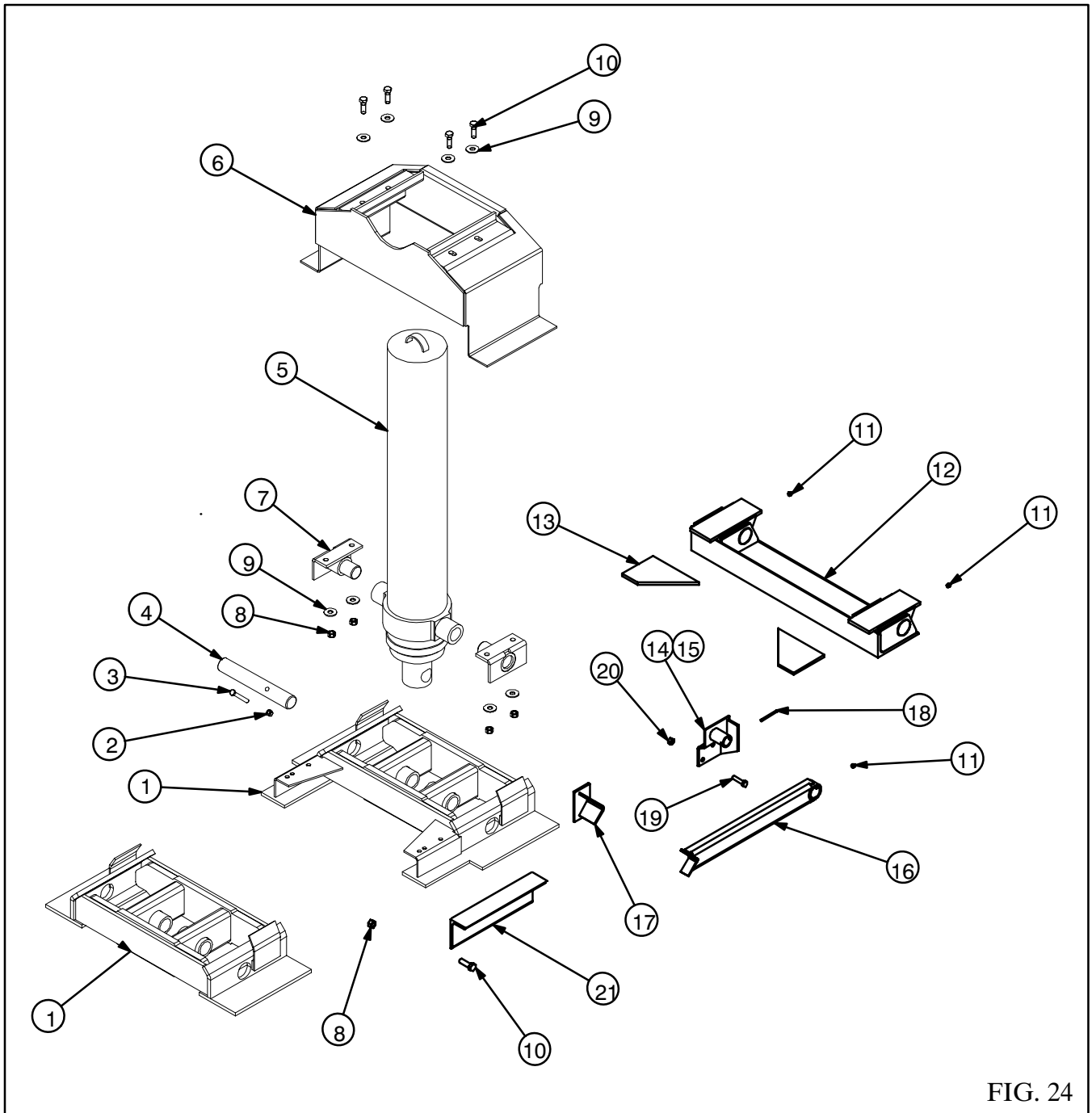

FIG. 24

ITEM	DESCRIPTION	Model	Part No	QTY
1.	Assy Lower Mount without Reservoir Brackets Assy Lower Mount with Reservoir Brackets	All	144668 144669	1 1
2.	Hex Lock Nut 1/2–13	All	401316	5
3.	Cap Screw 1/2 X 3 1/4 Hex Hd	All	401140	1
4.	Pin Hoist Pivot 13.31” Lg	All	246994	1
5.	Assy Cylinder	M74161 M74181 M74201	404766 404767 404768	1 1 1
6.	Assy Upper Lift M74	All	144673	1
7.	Assy Upper Pivot	All	130709	2
8.	Hex Lock Nut 5/8–11	All	401582	16
9.	Flat Washer 5/8	All	403132	18
10.	Cap Screw 5/8 X 2 HH	All	402374	16
11.	Grease Zerk 1/8 NPT	All	400103	4
12.	Assy Rear Hinge	All	107037	1
13.	Gusset Rear Hinge	All	402339	2
14.	Assy Prop Pivot – L	All	104190	1
15.	Assy Prop Pivot – R	All	104191	1
16.	Assy Body Prop Arm	All	101220	2
17.	Assy Prop Bracket	All	125259	2
18.	Spring Pin 1/4 X 3	All	400220	2
19.	Cap Screw 1/2 X 2 Hex Hd	All	400105	4
20.	Angle Mounting – 25”	All	246995	2
21.	Seal Kit	All	403153	1

MARATHON HYDRAULIC SYSTEM PARTS

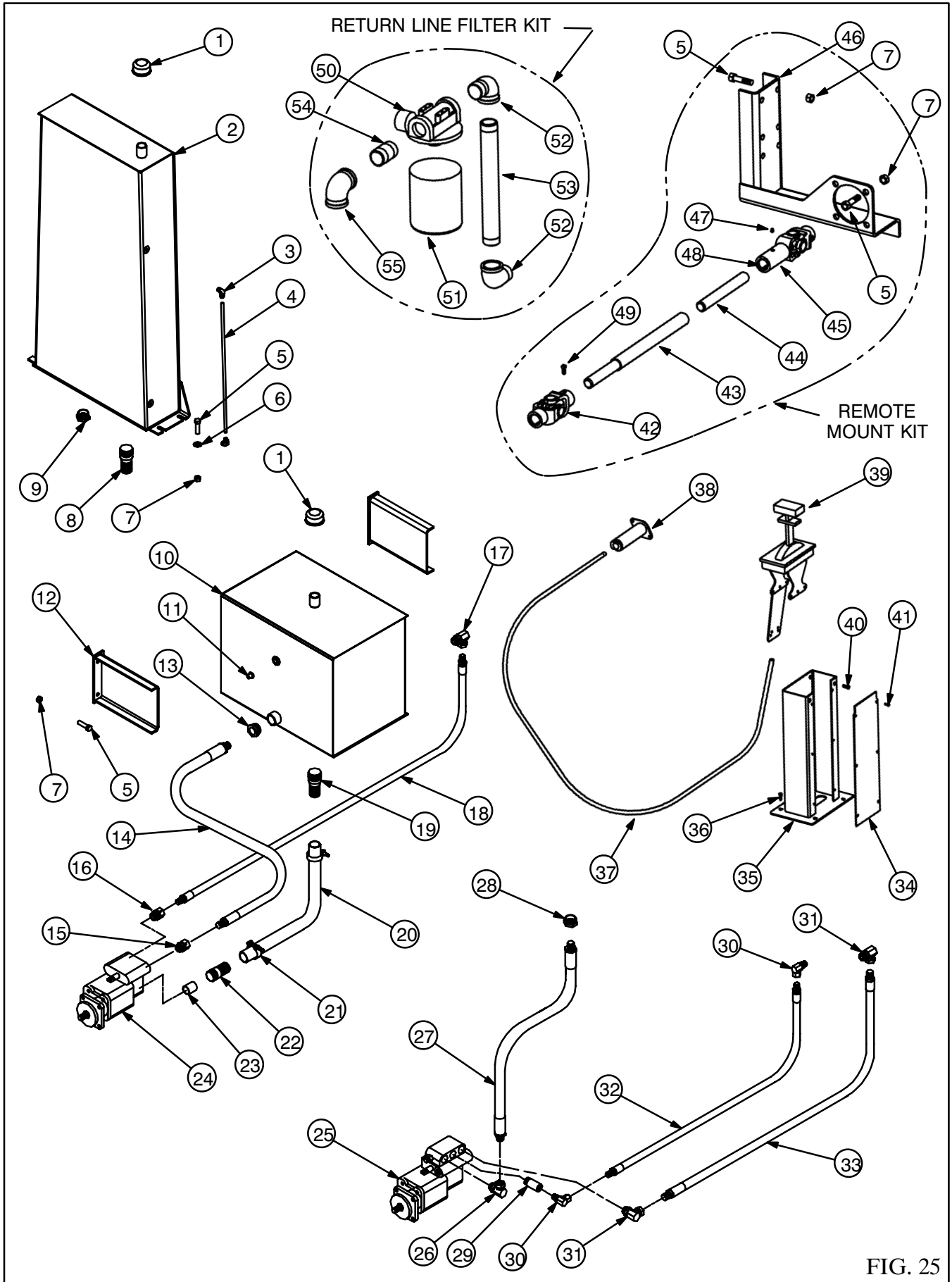

FIG. 25

ITEM«	DESCRIPTION	MODEL	PART NO	QTY.
1.	Breather Cap	All	400764	1
2.	Reservoir Assy 30 Gal Upright	M74	107360	1
3.	Elbow 3/8NPT x 3/8 Tube	M74	402296	2
4.	Tube 3/8 O.D.	M74	402297	3.5'
5.	Cap Screw 1/2 x 2 Hex Hd	All	400105	4
6.	Flat Washer 1/2	M74	400176	4
7.	Hex Lock Nut 1/2–13	All	401316	4
8.	Hose Barb 1 1/2 NPT x 1 1/2	M74 Upright Reservoir	402148	1
9.	Bushing Hex Reducing 1 1/2 x 1 1/4	M74 Upright Reservoir	402149	1
10.	Reservoir Assy 16 Gal	M5390–M5399	113744	1
	23 Gal	M53117	113745	1
	28 Gal	M63	113746	1
	40 Gal	M74	115465	1
11.	Sight Glass	All	401433	1
12.	Mounting Bracket	All	127123	2
13.	Bushing Hex Reducing 1 1/4 x 1	M53 M63 & M74	404915 Not Req'd	1
14.	Hose 1 NPT x 72" Lg	M53	405200	1
	1 1/4 NPT x 72" Lg	M63 & M74	405201	1
15.	Swivel Adapter 1 1/16 ORB x 1 NPT	M53	405331	1
	1 NPT x 1 1/4 NPT	M63 & M74	405332	1
16.	Swivel Adapter 1 1/16 ORB x 3/4 NPT	M53 M63 & M74	401657 Not Req'd	1
17.	Adapter 1 1/16 ORB x 3/4 NPT 90°	M53	401291	1
	1 5/16 ORB x 1 NPT 90°	M63 & M74	404904	1
18.	Hose 3/4 NPT x 60" Lg	M53	401563	1
	1" NPT x 60" Lg	M63 & M74	404905	1
19.	Hose Barb 2 NPT x 1 1/2	All	401724	1
20.	Suction Hose 1 1/2" ID x 72" Lg	All	401727	1
21.	Hose Clamp	All	402163	2
22.	Hose Barb 1 1/4 NPT x 1 1/2	All	401725	1
23.	Suction Port Sleeve	All	401540	1
24.	Pump / Valve – Single Acting			
	SA 10 GPM 'G' Series	M5390–M5399	405196	1
	SA 15 GPM 'G' Series	M53117	405197	1
	SA 20 GPM 'C' Series	M63	405198	1
	SA 25 GPM 'C' Series	M74	405199	1
25.	Pump / Valve – Double Acting			
	DA 10 GPM 'G' Series	M5390–M5399	405193	1
	DA 15 GPM 'G' Series	M53117	405194	1
	DA 19 GPM 'G' Series	M63	405195	1
26.	Adapter 1 1/16 ORB x 3/4 NPT 90°	M53 DA	401291	1
	1 1/16 ORB x 1 NPT 90°	M63 DA	404615	1
27.	Hose 3/4 NPT x 72" Lg	M53 DA	401982	1
	1" NPT x 72" Lg	M63 DA	401993	1

28.	Bushing Hex Reducing 1 1/4 x 3/4 1 1/4 x 1	M53 DA M63 DA	401452 404915	1 1
29.	Extension 1 1/16 ORB x 3/4 ORB	M53 DA & M63 DA	214157	1
30.	Adapter 3/4 ORB x 3/8 NPT 90°	M53 DA & M63 DA	401199	1
31.	Adapter 1 1/16 ORB x 3/4 NPT 1 1/16 ORB x 1 NPT 90°	M53 DA M63 DA	401291 404615	1 1
32.	Hose 3/8 NPT x 60" Lg	M53 DA & M63 DA	401564	1
33.	Hose 3/4 NPT x 60" Lg 1 NPT x 60" Lg	M53 DA M63 DA	401563 404905	1 1
34.	Cover, Pedestal Side	All	211236	1
35.	Pedestal Assy, Shifter	All	108818	1
36.	Self-Tapping Screw 5/16 x 3/4	All	400112	4
37.	Control Cable, Shifter – 7' 10'	All All	403250 401476	1 1
38.	Valve Connection Kit 'G' Series 'C' Series	M53 & M63 DA M63 SA & M74	401561 402010	1 1
39.	Shifter Control	All	401474	1
40.	Machine Screw 1/4 x 1/2	All	401527	4
41.	Self-Tapping Screw #10 x 3/8	All	400108	6
	Remote Mount Kit (includes Items 42–49)	All	107126	1
42.	U-Joint 1" Rd x 1" Rd	All	400584	1
43.	Drive Shaft Assy 29" Lg	All	100092	1
44.	Drive Shaft 1" Rd x 8" Lg	All	400605	1
45.	U-Joint, Slip 1" Rd x 13T Spline	All	401554	1
46.	Pump Mounting Bracket	All	107130	1
47.	Grease Zerk 1/8 NPT	All	400103	3
48.	Square Key 1/4 x 2	All	400224	2
49.	Set Screw 3/8 x 1/2 Sq Hd	All	400102	3
	Return Line Filter Kit (includes Items 50–55)	All	107127	1
50.	Filter Head w/ Indicator	All	400896	1
51.	Filter Element	All	401087	1
52.	Pipe Elbow 1 1/4 Street	All	401296	2
53.	Pipe 1 1/4 x 13" Lg	All	401592	1
54.	Pipe Nipple 1 1/4	M53 M63 & M74	401259 Not Req'd	1
55.	Pipe Elbow 1 1/4 x 1 Reducing 90° 1 1/4 Street	M53 M63 & M74	401722 401296	1 1

NOTES

SPECIALLY DESIGNED – WITH QUALITY IN MIND

CUSTOMER SATISFACTION PLEDGE

Crysteel's Customer Satisfaction Pledge is designed to be the most comprehensive warranty in the truck equipment industry. This pledge covers new products for a period of five (5) years, and is not restricted by vehicle mileage or when product is invoiced to our distributors. Our warranty begins when our product is put into service by the final customer.

This warranty covers our products for defective material and/or workmanship at a rate of 100 % for the first (3) years and at a rate of 50 % for years 4 and 5. This warranty covers:

- Crysteel Manufactured product
- OEM Products purchased by Crysteel as part of our product
- The repair of warranted product
- The replacement of warranted product
- Labor to replace warranted product
- Freight for replacement product
- Warranted product return freight (if required)

This warranty is limited to product supplied under the Crysteel Mfg. name and does not cover distributor modifications. Repair or replacement is at Crysteel's option. Primer warranty is limited to adherence to metal surfaces only and does not include the inside or understructure of dump bodies. Crysteel will not assume responsibility for travel, loss of use, downtime expenses or other incidental or consequential damages. This warranty is void if the product has been obviously abused or subjected to other than normal usage. There are no other warranties except as described above, and Crysteel makes no warranty of fitness for a particular purpose.

! CAUTION !

- **BODY MUST BE BRACED BEFORE SERVICING HOIST OR WORKING IN AREA WITH BODY IN RAISED POSITION**
- **LUBRICATE HOIST GREASE FITTINGS OFTEN – AT LEAST EACH TIME TRUCK IS SERVICED**
- **TRUCK MUST BE LEVEL FOR DUMPING**
- **DO NOT OVERLOAD**

CRYSTEEL MFG, INC.

CRYSTEEL MANUFACTURING, INC.

P.O. Box 178 52182 Ember Road
Lake Crystal, MN 56055

1902 Route 57 South
Fulton, NY 13069

(507) 726-2728 (800) 533-0494