

CRYSTEEL'S ROLLERCOMBO HOIST



P.O. Box 178
52182 Ember Road
Lake Crystal, MN 56055

www.crysteel.com
crysteel@crysteel.com
(507) 726-2728 (800) 533-0494

1902 Route 57 South
Fulton, NY 13069

DATE PURCHASED _____
BODY SERIAL NUMBER _____
HOIST SERIAL NUMBER _____
CYLINDER SERIAL NUMBER _____
PUMP SERIAL NUMBER _____
DEALER _____
ADDRESS _____
PHONE _____

FOREWORD

Crysteel's Roller-Combo Hoist is a heavy duty underbody hoist designed and intended for use under dump bodies. The Roller-Combo Hoist line consists of 7 sizes that fit single-, tandem- and triple-axle trucks. The Roller-Combo Hoist is a patented combination of two underbody hoist principles, the scissors and the double-arm hoist.

Crysteel makes several lines of dump bodies that can be used with the Roller-Combo Hoist. All of these are custom built to fit the Roller-Combo Hoist and come in a range of sizes from 8 through 18 feet and 2 through 25 cubic yards in capacity.

This manual contains the information needed for the proper installation and operation of Crysteel's RollerCombo Hoist. With proper installation, use, and regular maintenance, this hoist will give many years of trouble free service.

When ordering parts, be sure to give the serial number of hoist, pump, and cylinder. The serial number of the pump is found on the plate on the pump. The serial number of the cylinder is stamped on the barrel of the cylinder near the base. For future reference, copy these numbers NOW in the space provided above. Order parts by number and description as given in the parts listing in this manual.

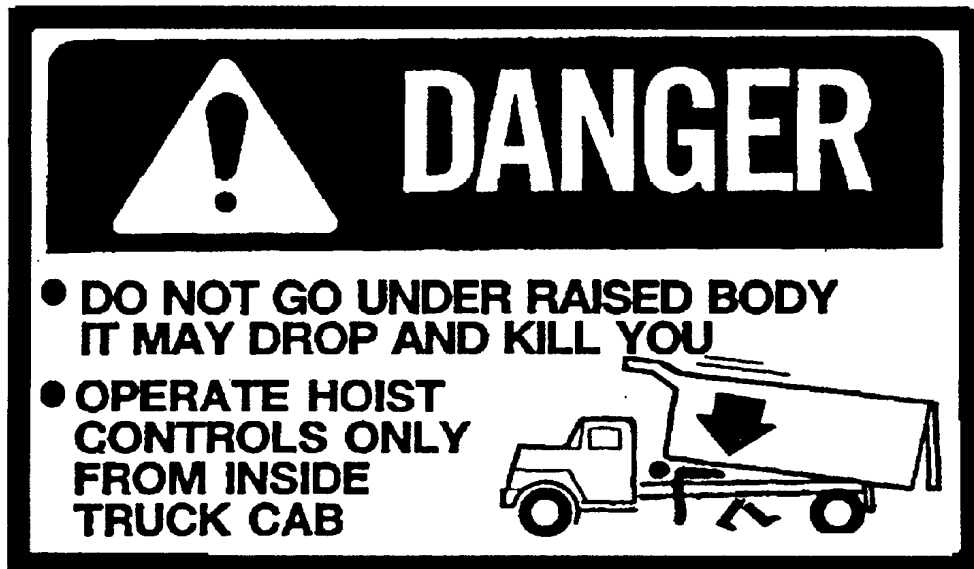

OPERATION AND USE

1. Engage PTO from cab and adjust engine speed to fast idle.
2. ALWAYS operate the hoist from inside the cab of the truck.
3. If the hydraulic hose connections are correct, the hoist should raise when the hoist control lever is pulled back, hold when the lever is in the center detent, and lower when the lever is pushed forward.
4. To raise the hoist, pull the control lever back. To hold the body in a raised position, place the control lever in its center detent position. To lower the hoist, push the control lever forward.
5. ALWAYS return the hoist control lever to its center detent position after each use.
6. When the hoist cylinder reaches the end of the stroke, oil will flow through the automatic bypass valve built into the piston inside the cylinder and return to the reservoir.
7. It is advisable to run the PTO to “power down” or lower the hoist because this will act as a hydraulic lock to hold the hoist in the lowered position. It is not necessary to do this, however, because the reservoir has sufficient capacity whether or not the hoist is powered down. You will benefit from the advantages of the double acting hoist only if you power down.
8. To make use of the hydraulic lock feature, place the hoist control lever in the center hold position after the hoist is powered down. This places the pressure on the valve, where it belongs, not on the pump.
9. **DO NOT LEAVE THE PTO IN GEAR WHILE TRANSPORTING. THIS CAN CAUSE SEVERE DAMAGE TO THE PTO OR HYDRAULIC PUMP.**
10. The hydraulic system should be drained, flushed and refilled with proper hydraulic fluid at regular intervals. **CAUTION: NEVER use hydraulic BRAKE FLUID in the hydraulic system.**
11. After adding or replacing the hydraulic fluid, cycle the hoist several times to remove air from the cylinders and hydraulic hoses.

SOME DO'S AND DON'TS FOR SAFE AND LONG SERVICE

1. Use the proper hydraulic fluid. **KEEP IT CLEAN.** Remember to change it regularly.
2. Lubricate all grease fittings at regular intervals.
3. ALWAYS carefully block up the body, using the body prop, before working under it.
4. Do not “race” the engine when unloading.
5. Do not load the hoist beyond its capacity.
6. **DO NOT tamper with the hydraulic relief valve.** This will void the warranty. It can cause severe damage to the hoist and cylinder.
7. Never leave the PTO in gear while transporting. It could ruin the hydraulic pump, the PTO or the transmission.
8. Check all bolts and fittings regularly. Keep them tight.

TABLE OF CONTENTS

Purchase Record	1
Foreword	1
Operation and Use	2
Some Do's and Don't's	2
Table of Contents	3
Locate Hoist/Subframe Assembly – Single–Axle Trucks	4
Locate Hoist/Subframe Assembly – Tandem–Axle Trucks	4
Locate Body/Hoist on Truck	5
Locate Mounting Plates	5
Drill Truck Frame – All Models	6
Weld Rear Hinge and Subframe – All Models	6
Mount Gear Pump	7
Mount Reservoir/Valve Assembly	7
Install Remote Valve Control	7–8
Install Hoses – Models RC540 & RC650	8–9
Install Hoses – Model RC750	9
Install Hoses – Model RC860	9–10
Install Hoses – Model RC580	10
Install Hoses – Model RC690 & RC6100	10–11
Add Hydraulic Fluid	11
Power Hoist Down	11
Assemble Body and Install on Truck	12
Install Body Guides	13
Install Body Prop Bracket – RC540–RC860	14
Install Body Props – RC580–RC6100	15
Install Grease Zerks and Lubricate	16
Install Lights, Reflectors and Decals	16
Parts Lists and Diagrams	18–26

INSTALLATION INSTRUCTIONS

LOCATE HOIST/SUBFRAME ASSEMBLY – SINGLE-AXLE TRUCKS

Place the hoist–subframe assembly on the truck frame so the back edge of the rear hinge is 2 inches or more behind the back side of the spring shackle, as shown in Fig. 1. This will place the rear hinge pivot 32 to 35 inches behind the center of the rear axle. Mark the rear of the truck frame, as shown in Fig. 4.

Crysteel recommends that the subframe crossmember under the back end of the hoist be supported if the unit is to be subjected to severe service. To do this a crossmember may be added to the truck frame. On the truck frame, mark the location of the flange of the hoist subframe crossmember, this will be the location of the added crossmember for supporting the subframe crossmember. Remove the hoist–subframe assembly from the truck and cut the truck frame as marked. At the location marked for the hoist subframe crossmember, install a crossmember (not supplied) in the truck frame.

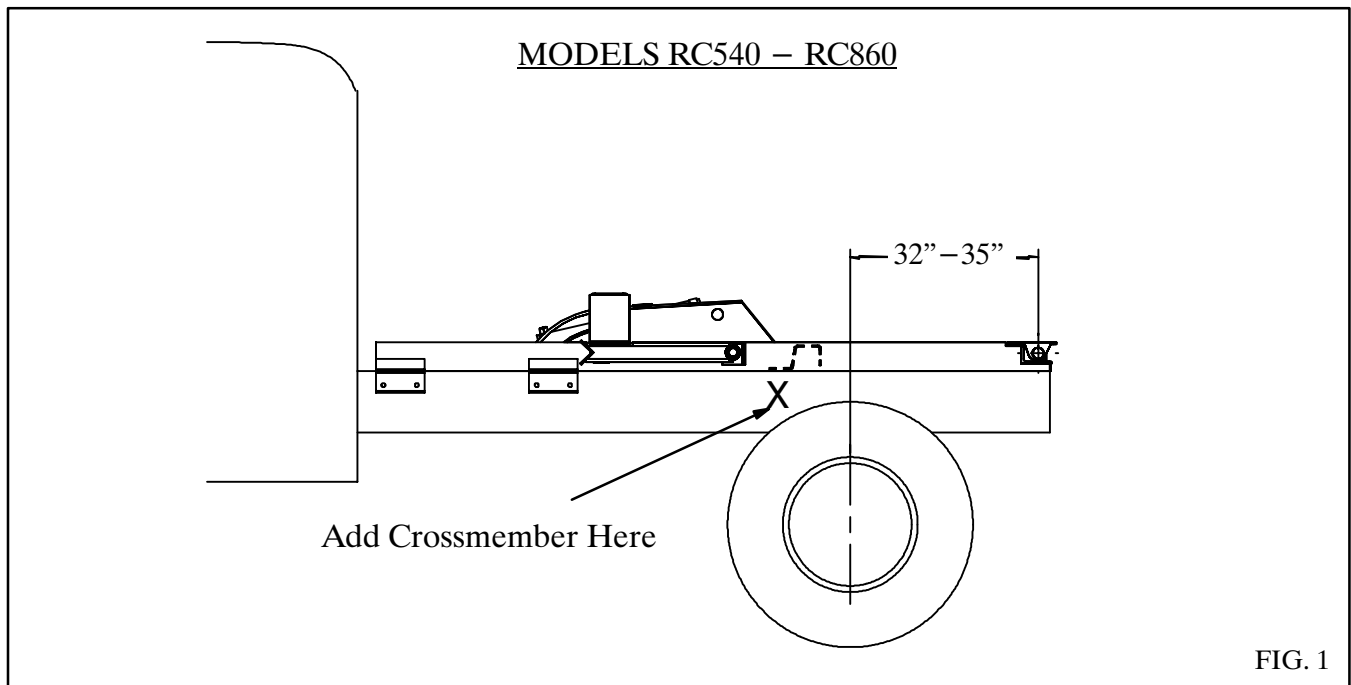

NOTE: If the truck frame has rivets in the top flange, add spacers between the truck frame and subframe, or counter sink the rivet heads into the subframe by drilling holes in the subframe. Do not remove the rivet heads!

LOCATE HOIST/SUBFRAME ASSEMBLY – TANDEM-AXLE TRUCKS

Place the hoist–subframe assembly on the truck frame, as shown in Fig. 2. The rear pivot should be located 42 to 45 inches behind the center of the tandem on tandem axle trucks – never more than 50 inches. Mark the rear of the truck frame as shown in Fig. 4.

Crysteel recommends that the subframe crossmember under the back end of the hoist be supported if the unit is to be subjected to severe service. To do this a crossmember may be added to the truck frame. On the truck frame, mark the location of the flange of the hoist subframe crossmember, this will be the location of the added crossmember for supporting the subframe crossmember. Remove the hoist–subframe assembly from the truck and cut the truck frame as marked. At the location marked for the hoist subframe crossmember, install a crossmember (not supplied) in the truck frame.

NOTE: If the truck frame has rivets in the top flange, add spacers between the truck frame and subframe, or counter sink the rivet heads into the subframe by drilling holes in the subframe. Do not remove the rivet heads!

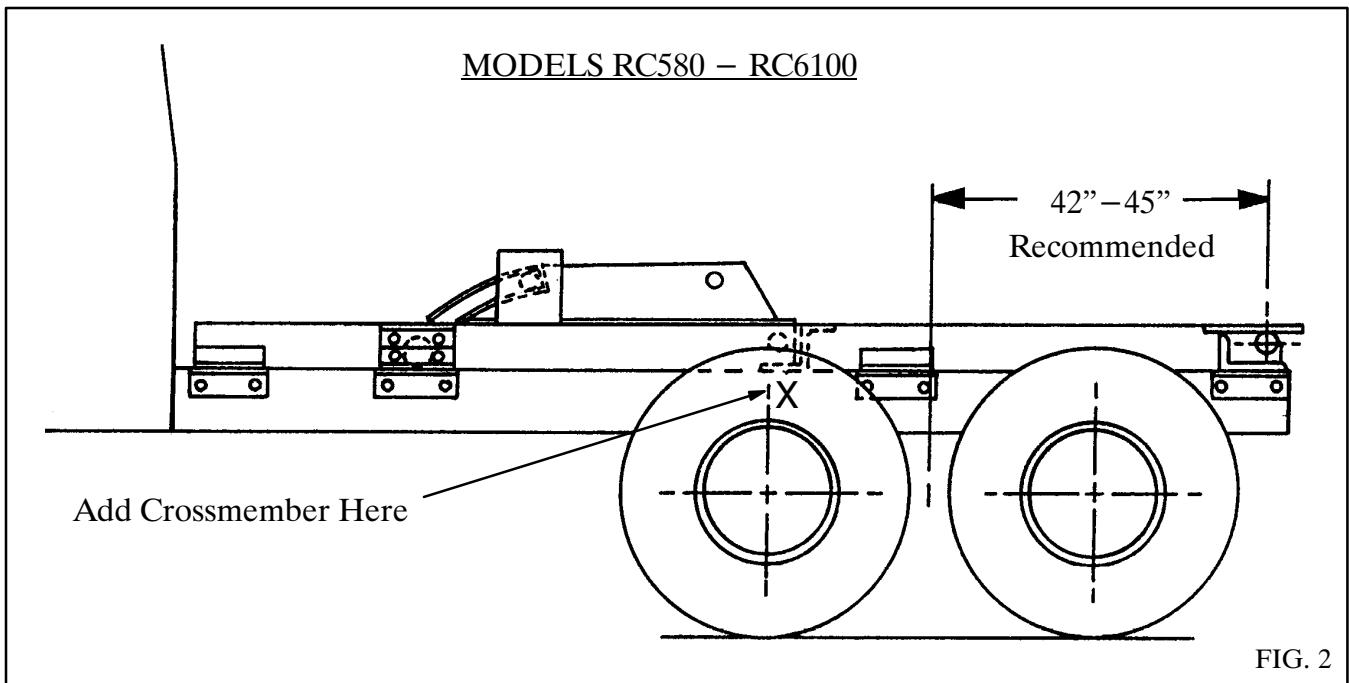

LOCATE BODY/HOIST ASSEMBLY ON TRUCK

Use the following installation procedures when the body and hoist have been assembled at the factory.

On single-axle trucks, place the body and hoist assembly on the truck frame so the back edge of the rear hinge is 2 inches or more behind the back side of the spring shackle. On tandem-axle trucks, place the body and hoist assembly so the rear pivot is 42"–45" behind the center of the tandem. This should give 3 to 5 inches of cab clearance. The truck frame will need to be cut off even with the back end of the subframe rails. Relocate the body and hoist, if necessary. The center of the rear hinge should never be more than 36 inches behind the center of the rear axle on single-axle trucks or 50 inches on tandem-axle trucks.

Crysteel recommends that the subframe crossmember under the back end of the hoist should be supported if the unit is to be subjected to severe service. To do this add a crossmember (not supplied) to the truck frame under the bottom flange of the subframe crossmember. On the truck frame, mark the location of the flange of the hoist subframe crossmember, this will be the location of the added crossmember for supporting the subframe crossmember. Mark the rear of the truck frame for shortening as shown in Fig. 4.

Block up the back end of the body/hoist assembly and cut the truck frame as marked. At the location marked for the hoist subframe crossmember, install a crossmember, (not supplied) in the truck frame.

NOTE: If the truck frame has rivets in the top flange, add spacers between the truck frame and subframe, or counter sink the rivet heads into the subframe by drilling holes in the subframe. Do not remove the rivet heads!

LOCATE MOUNTING PLATES

There are six mounting plates, three for each side – one at the front of the subframe, one at the hoist mount and one between the hoist mount and the rear hinge. Clamp the mounting plates to the truck frame and to the subframe as shown in Fig. 3. If desired, locate the plates to use existing holes in the frame. Mark the mounting plates for drilling. Repeat this for the other side.

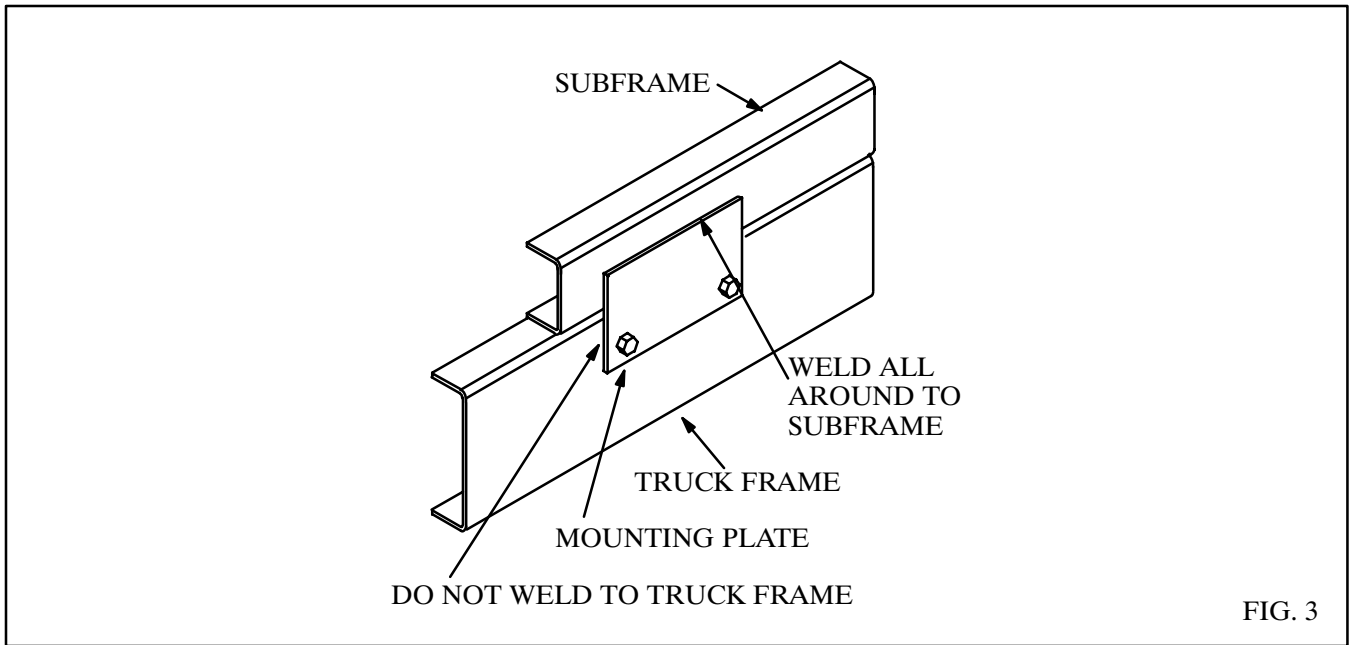

FIG. 3

CAUTION: BE CAREFUL OF BRAKELINES, WIRING, ETC. INSIDE THE TRUCK FRAME WHEN DRILLING THE TRUCK FRAME.

DRILL TRUCK FRAME – ALL MODELS

Drill 21/32” holes in the mounting plates and the truck frame. Bolt the mounting plates in place using 5/8 x 2 cap screws (grade 8) and hex lock nuts, tightening to 180–190 lb–ft.

WELD REAR HINGE AND SUBFRAME – ALL MODELS

Make sure the body/hoist assembly or hoist/subframe assembly is correctly located, centered on and square with the truck frame. Securely weld the mounting plates to the subframe. Add a plate to cap the end of the truck frame. (See Fig. 4.) Securely weld the back end of the truck frame rail to the back end of the subframe. Do this on both sides. If a crossmember was added to the truck frame to support the subframe crossmember, add spacers between it and the subframe crossmember and weld in place.

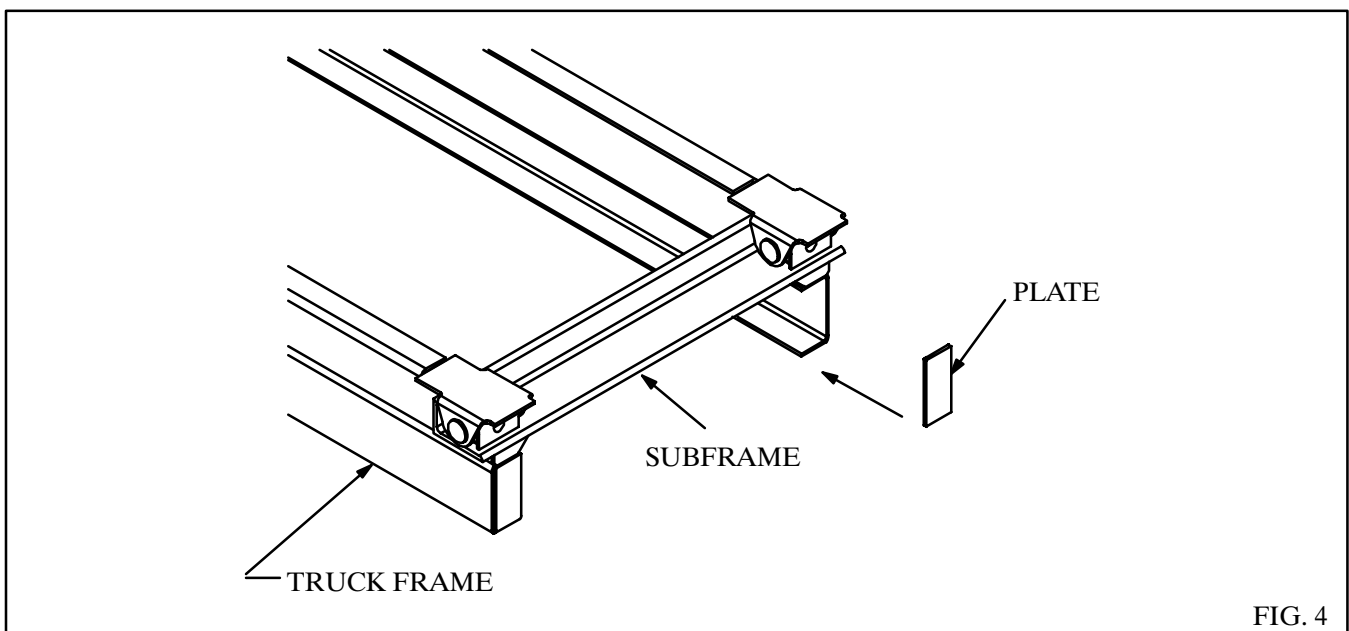

FIG. 4

MOUNT GEAR PUMP

The gear pump has an SAE 'B' mounting configuration, a 13 tooth splined shaft and a four-bolt mounting flange, and is assembled for rotation in either direction. **NOTE:** This pump will mount directly to Chelsea's output type 'XK' or Muncie's output type 'D'. Crysteel Manufacturing recommends a PTO ratio of 100–120%. This assures a minimum pump operating speed of 600 RPM. Bolt the gear pump to the PTO output flange using 1/2 x 1 1/4 cap screws and lock washers.

MOUNT RESERVOIR/VALVE ASSEMBLY

The reservoir/valve assembly is intended to be mounted just behind the cab, between the longbeams of the body with the control valve to the left (drivers) side of the truck.

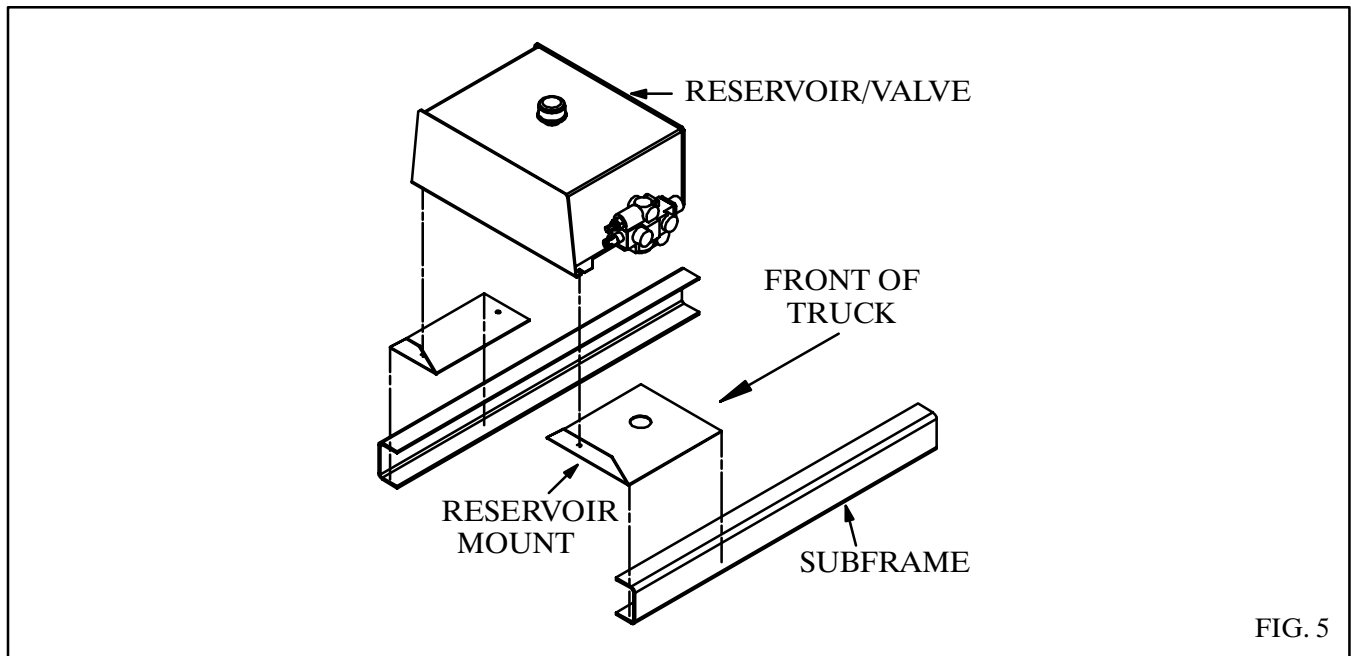

FIG. 5

Bolt the large mounting angle to the valve end of the reservoir/valve assembly and the small mounting angle to the other end using 3/8 x 1" cap screws, flat washers and hex lock nuts. Place this assembly between the subframe rails so the mounting angles are resting on the bottom flanges of the subframe rails and the front of the reservoir/valve assembly is 2" back from the front of the subframe. Securely weld the mounting angles to the subframe. (See Fig. 5.)

NOTE: If there is not enough room between the front of the body and the hoist, the reservoir/valve assembly will need to be mounted to the outside of the truck frame. Brackets will need to be made to do this.

INSTALL REMOTE VALVE CONTROL

Temporarily assemble the valve control head to the pedestal using 5/16 x 2 1/4" machine screws and hex nuts. Place this assembly on the floor of the cab. Make sure there is enough room to operate the valve control and the gear shift lever and to adjust the seat. Check below the floor for obstructions and cable routing. Relocate the valve control if necessary. Mark the floor using the pedestal as a template and drill 1/4" holes for the mounting screws and a 3/4" hole for the control cable. Assemble the control cable to the valve control head and assemble the valve control head and cover to the pedestal using 5/16 x 2 1/4" machine screws, hex lock nuts. Insert the control cable through the hole in the floor and mount the pedestal to the floor using 5/16 x 1/2 machine screws and hex lock nuts. Make sure the valve control lever is in its center detent position. Keep the control cable away from hot exhaust pipes and rotating drive shafts. The control cable should not have any sharp bends or kinks in it (these will make the control harder to operate).

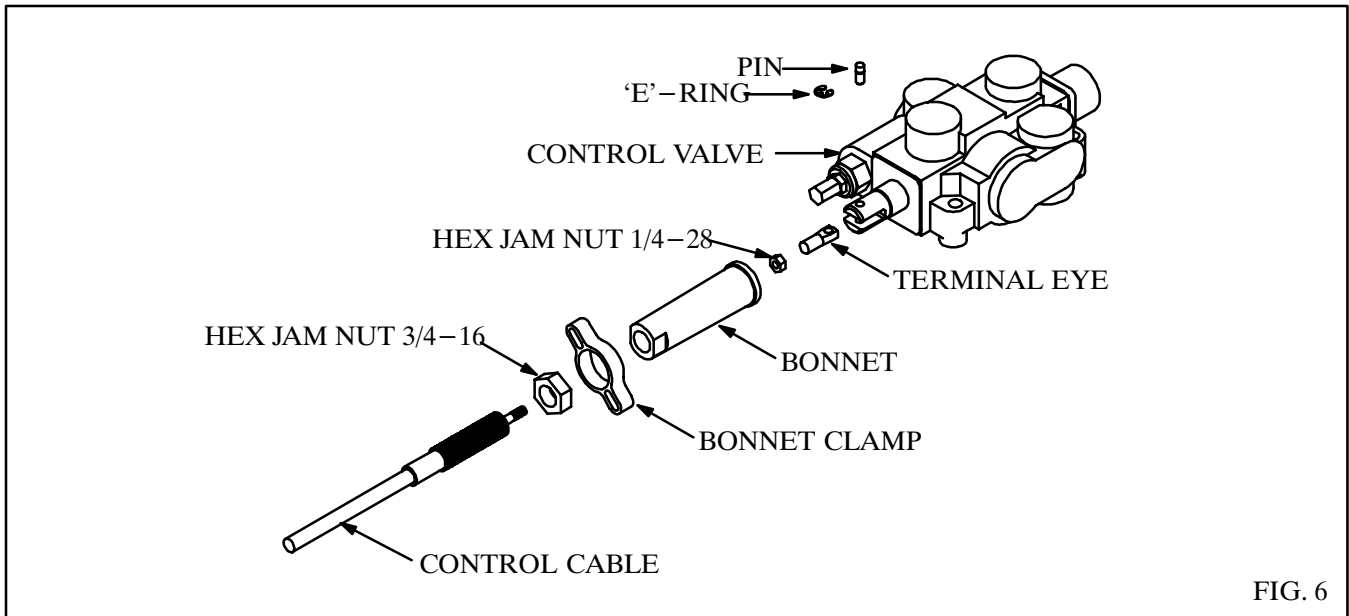

FIG. 6

Install the 3/4" hex jam nut onto the valve end of the control cable and turn it past the threads. Insert the end of the cable through the bonnet clamp. Install the bonnet onto the control cable and turn it past the threads also. Install the 1/4" hex jam nut and terminal eye on the core rod of the cable; lock the terminal eye to the core rod of the cable using the hex jam nut. Place the terminal eye in the slot of the valve spool; insert the short pin through the valve spool and terminal eye and secure it in place with the 'E' ring. Thread the bonnet onto the end of the cable so it firmly touches the end of the valve. (Do not over- or under-tighten the bonnet as either would move the valve spool out of its neutral position.) Remove two cap screws from opposite corners of the seal retainer plate. Slide the bonnet clamp onto the bonnet and secure it to the valve using the 1/4 x 1 1/4" cap screws, lock washers and flat washers. Lock the bonnet to the cable using the 3/4" hex jam nut. See Fig. 6.

INSTALL HOSES – MODELS RC540 & RC650

Study Fig. 7 very carefully before connecting the hoses. Install an 1 1/4" x 3/4" hex bushing, a 3/4" 90° street elbow and a 3/4" hose barb in the suction port on the bottom of the reservoir. Install a 3/4" hose barb in the suction port of the pump and install the suction hose. Secure the suction hose in place using hose clamps. Install a 90° swivel adapter in the 'IN' port of the control valve and install a 3/4 x 1/2 hex reducer in the pressure port of the pump. Install a 72" long 1/2" hose from the pump to the valve.

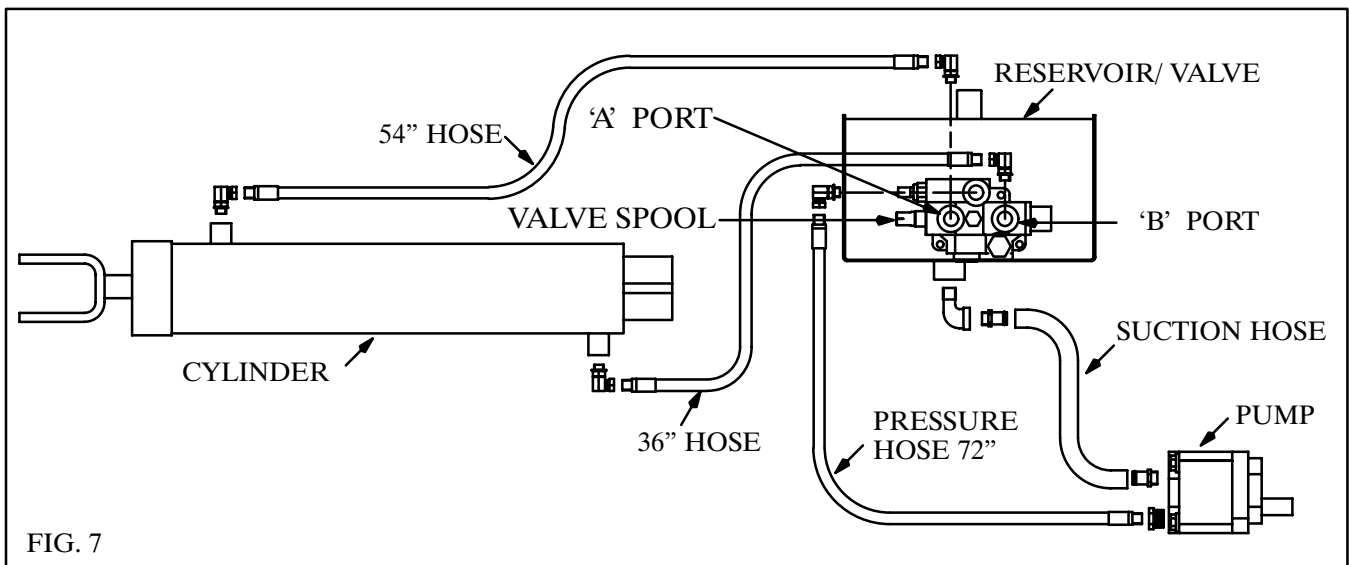

FIG. 7

Install 90° swivel adapters in the work ports of the control valve and in the ports on the cylinder. Connect the 36" long 1/2" hose from the 'B' port on the control valve to the base end port on the cylinder. Connect the 54" long 1/2" hose from the 'A' port on the control valve to the rod end port on the cylinder. This will raise the hoist when the control lever is pulled back and lower it when pushed forward.

NOTE: The 'A' port is the 'power-down' port and has a pressure of only 500–1000 PSI; the 'B' port has full system pressure.

INSTALL HOSES – MODEL RC750

Study Fig. 7 very carefully before connecting the hoses. Install an 1 1/4" 90° street elbow and an 1 1/4" hose barb in the suction port on the bottom of the reservoir. Install a 1 5/16 ORB x 1 1/4" hose barb in the suction port of the pump and install the suction hose. Secure the suction hose in place using hose clamps. Install a 90° swivel adapter in the 'IN' port of the control valve and install a 1 5/16 ORB x 1/2" NPT adapter in the pressure port of the pump. Connect a 72" long 1/2" hose from the pump to the valve.

Install 90° swivel adapters in the work ports of the control valve and in the ports on the cylinder. Connect the 36" long 1/2" hose from the 'B' port on the control valve to the base end port on the cylinder. Connect the 54" long 1/2" hose from the 'A' port on the control valve to the rod end port of the cylinder. This will raise the hoist when the control lever is pulled back and lower it when pushed forward.

NOTE: The 'A' port is the 'power-down' port and has a pressure of only 500–1000 PSI; the 'B' port has full system pressure.

INSTALL HOSES – MODEL RC860

Study Fig. 8 very carefully before connecting the hoses. Install an 1 1/4" 90° street elbow and an 1 1/4" hose barb in the suction port on the bottom of the reservoir. Install a 1 5/16 ORB x 1 1/4" hose barb in the suction port of the pump and install the suction hose. Secure the suction hose in place using hose clamps. Install a 90° swivel adapter in the 'IN' port of the control valve and install a 1 5/16 ORB x 3/4" NPT adapter in the pressure port of the pump. Connect a 72" long 3/4" hose from the pump to the valve.

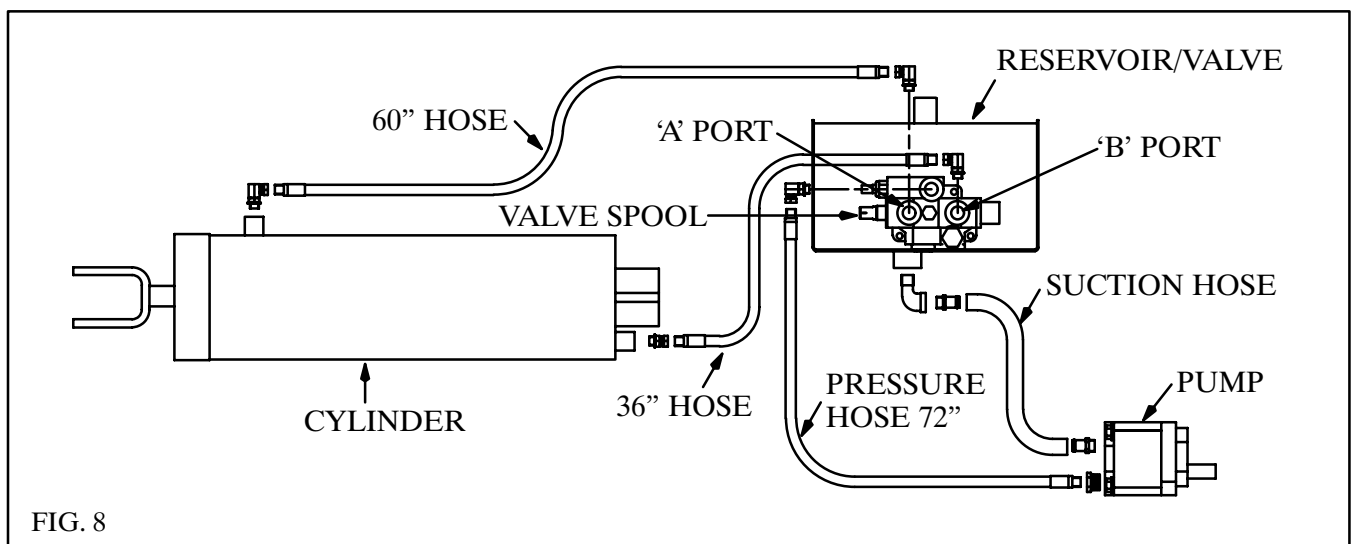

Install 90° swivel adapters in the work ports of the control valve and in the rod end port of the cylinder and a straight swivel adapter in the base end port. Connect the 36" long 3/4" hose from the 'B' port on the control valve to the base end port on the cylinder. Connect the 60" long 3/4" hose from the 'A' port on the control valve to the rod end port of the cylinder. This will raise the hoist when the control lever is pulled back and lower it when pushed forward

NOTE: The 'A' port is the 'power-down' port and has a pressure of only 500–1000 PSI; the 'B' port has full system pressure.

INSTALL HOSES – MODEL RC580

Study Fig. 9 very carefully before connecting the hoses. Install an 1 1/2" x 1 1/4" hex bushing, an 1 1/4" 90° street elbow and an 1 1/4" hose barb in the suction portion on the bottom of the reservoir. Install a 1 5/16 ORB x 1 1/4" hose barb in the suction port of the pump and install the suction hose. Secure the suction hose in place using hose clamps. Install a 90° swivel adapter in the 'IN' port of the control valve and install a 1 5/16 ORB x 1/2 NPT adapter in the pressure port of the pump. Connect a 72" long 1/2" hose from the pump to the valve.

Install 90° swivel adapters in the work ports of the control valve and in the ports of the cylinder. Connect a 24" long 1/2 NPT–7/8 ORB hose from the base end port of the right cylinder to the middle port of the 7/8" ORB tee; connect an 18" long 1/2 NPT–7/8 ORB hose from the base end port of the left cylinder to the 7/8 ORB tee and connect the 36" long 1/2 NPT–7/8 ORB hose from this tee to the 'B' port on the control valve.

Connect an 18" long 1/2 NPT–3/4 ORB hose from the rod end port of the right cylinder to the middle port of the 3/4 ORB tee; connect a 12" long 1/2 NPT–3/4 ORB hose from the rod end port of the left cylinder to the 3/4" ORB tee. Connect the 72" long 1/2 NPT–3/4 ORB hose from this tee to the 'A' port on the control valve. This will raise the hoist when the control lever is pulled back and lower it when pushed forward.

NOTE: The 'A' port is the 'power-down' port and has a pressure of only 500–1000 PSI; the 'B' port has full system pressure.

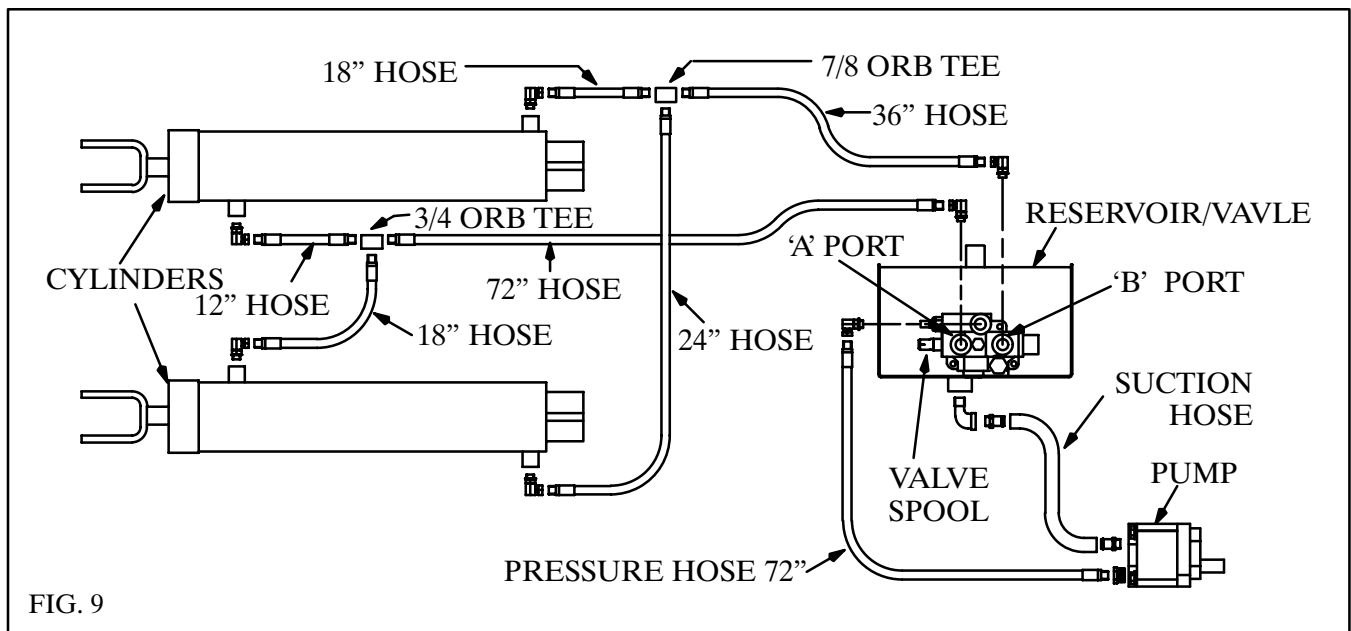

INSTALL HOSES – MODELS RC690 & RC6100

Study Fig. 9 very carefully before connecting the hoses. Install an 1 1/2" 90° street elbow, an 1 1/2" x 1 1/4" hex bushing and an 1 1/4" hose barb in the suction port on the bottom of the reservoir. Install a 1 5/16 ORB x 1 1/2" hose barb in the suction port of the pump and install the suction hose. Secure the suction hose in place using hose clamps. Install a 90° swivel adapter in the 'IN' port of the control valve and install a 1 5/16 ORB x 3/4 NPT adapter in the pressure port of the pump. Connect a 72" long 3/4" hose from the pump to the valve.

Install 90° swivel adapters in the work ports of the control valve and in the ports of the cylinder. Connect a 24" long 1/2 NPT–7/8 ORB hose from the base end port of the right cylinder to the middle port

of the 7/8 ORB tee; connect an 18” long 1/2 NPT–7/8 ORB hose from the base end port of the left cylinder to the 7/8 ORB tee. Install a 7/8 ORB x 3/4 NPT swivel adapter in the third port of the 7/8 ORB tee and connect the 36” long 3/4” hose from this tee to the ‘B’ port on the control valve.

Connect an 18” long 1/2 NPT–3/4 ORB hose from the rod end port of the right cylinder to the middle port of the 3/4 ORB tee; connect a 12” long 1/2 NPT–3/4 ORB hose from the rod end port of the left cylinder to the 3/4 ORB tee. Install a 3/4 ORB x 3/4 NPT swivel adapter in the third port of the 3/4 ORB tee and connect the 72” long 3/4” hose from the 3/4 ORB tee to the ‘A’ port on the control valve. This will raise the hoist when the control lever is pulled back and lower it when pushed forward.

NOTE: The ‘A’ port is the ‘power–down’ port and has a pressure of only 500–1000 PSI; the ‘B’ port has full system pressure.

ADD HYDRAULIC FLUID

Use a quality hydraulic fluid of 150 SSU @ 100° F which contains corrosion and oxidation inhibitors and a foam depressant. This is approximately the equivalent of SAE 10W or lighter weight oil. Initially fill the reservoir with the quantities given below. **DO NOT OVERFILL THE RESERVOIR!**

KEEP THE OIL CLEAN! USE CLEAN CONTAINERS, FUNNELS AND OTHER EQUIPMENT!

With normal use and working conditions the hydraulic oil should be changed annually. The breather cap should be cleaned every time the hydraulic oil is changed. With heavy use or very dusty working conditions the hydraulic oil should be changed more often.

HOIST MODEL	RESERVOIR SIZE	FLUID REQUIRED
RC540 RC650 RC750 RC860	10 GAL	7 GAL
RC580 RC690 RC6100	18 GAL	13 GAL

NOTE: If the pump does not pump oil, pressurize the reservoir and engage the pump with the engine at slow idle. Once the pump is working, release the pressure and install the breather cap.

POWER HOIST DOWN

Before mounting the body, the hoist must be completely closed to make certain the hoist gives full lift height and performance. **NOTE:** If the body and hoist have been assembled at the factory, this step is not necessary.

Push the upper cross channel all the way to the back of the roller tracks. Start the truck engine, engage the PTO and power down the hoist to “bottom out” the hydraulic cylinder and the hoist frame. Place the valve control in the center “hold” position and shut off the truck engine. The hoist is now fully closed.

It is **VERY IMPORTANT** that the Roller–Combo Hoist be installed with the upper cross channel pushed all the way to the back of the roller tracks. (See Fig. 10) This provides the extra leverage the hoist needs to start the load. If the hoist is not installed correctly, it will not have its full lift height and capacity. The results would be extreme over–loading of the hoist and the possibility of severe damage to the hoist and/or truck.

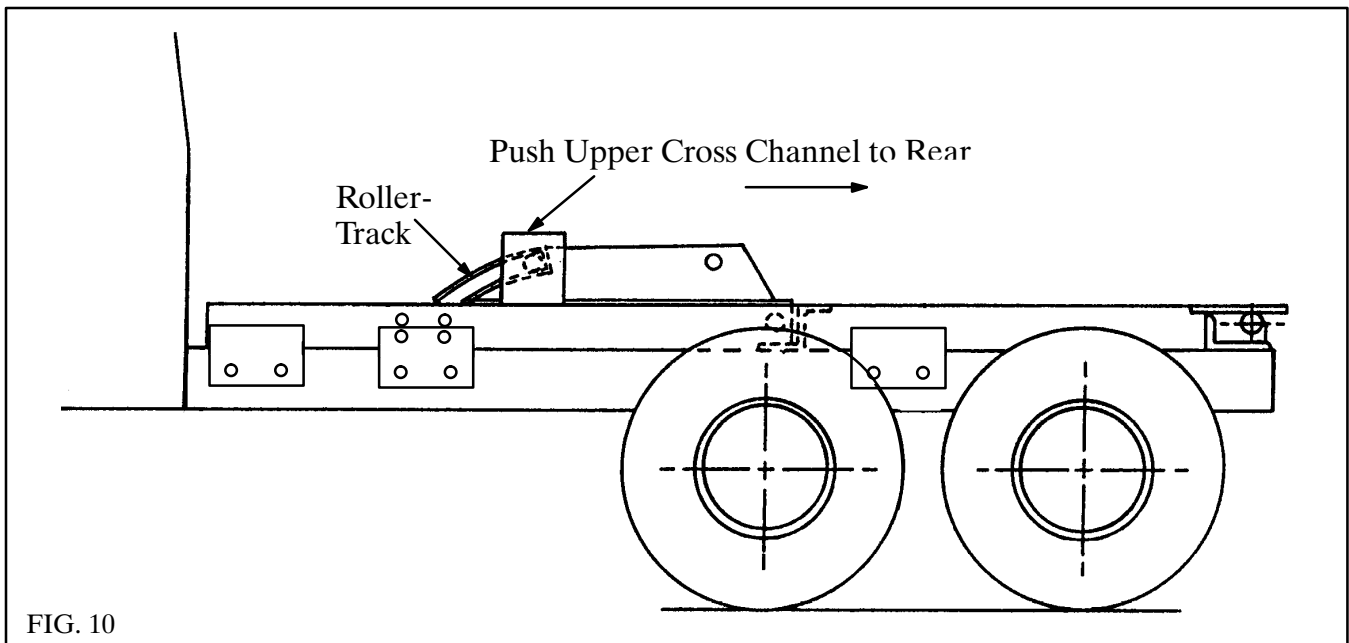

FIG. 10

ASSEMBLE BODY AND INSTALL ON TRUCK

Crysteel dump bodies are custom built to fit the Roller-Combo Hoist. The Roller Combo Hoist subframe is custom-made to match the dump body length. To check the amount of overhang, measure from the front of the subframe to the center line of the rear hinge and subtract that distance from the body length. That distance is the overhang.

NOTE: If a different overhang is desired, crossmembers may need to be notched for hoist clearance. Any notched crossmember must be reinforced to provide adequate floor support.

On other bodies, the inside of the longbeams must be boxed in to provide a flat surface for welding the hoist lift plates to the body. Some crossmembers may need to be notched to provide clearance for the hoist. Any notched crossmembers must be reinforced to provide adequate floor support. Box in the longbeams and notch the crossmembers where necessary after carefully measuring the hoist.

It is recommended that the body be painted before it is mounted on the truck. **CAUTION!** When mounting the body, be careful so the upper cross channel remains all the way back in the roller tracks and square with the hoist. (See Fig. 10) Place the body on the truck allowing 3 inches of clearance between the truck cab and the body. Securely weld the longbeams to the rear hinge plates. Securely weld the hoist lift brackets to the outside of the longbeams. (See Fig. 11.) Raise the body and securely block the body in the raised position. Securely weld the hoist lift brackets to the inside of the longbeams.

DO NOT WORK UNDER A RAISED BODY UNLESS THE BODY IS SECURELY BLOCKED OR PROPPED IN THE RAISED POSITION.

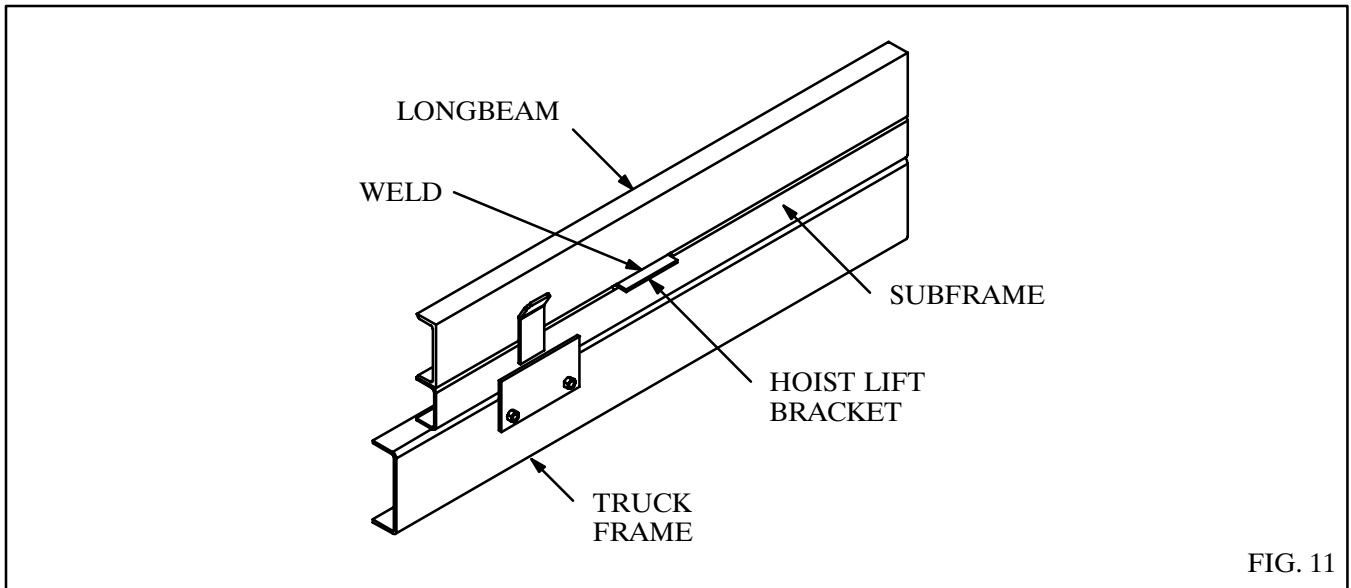

DO NOT WORK UNDER A RAISED BODY UNLESS THE BODY IS SECURELY BLOCKED OR PROPPED IN THE RAISED POSITION.

INSTALL BODY GUIDES

Two body guides have been included and should be mounted near the front of the subframe. Clamp the body guides to the outside of the subframe as shown in Figs. 12 and 13. The body guide should be tight against the outside of the longbeams of the body. Securely weld the body guides to the subframe.

There should be **NO SIDEPLAY** when the truck body is in the lowered position.

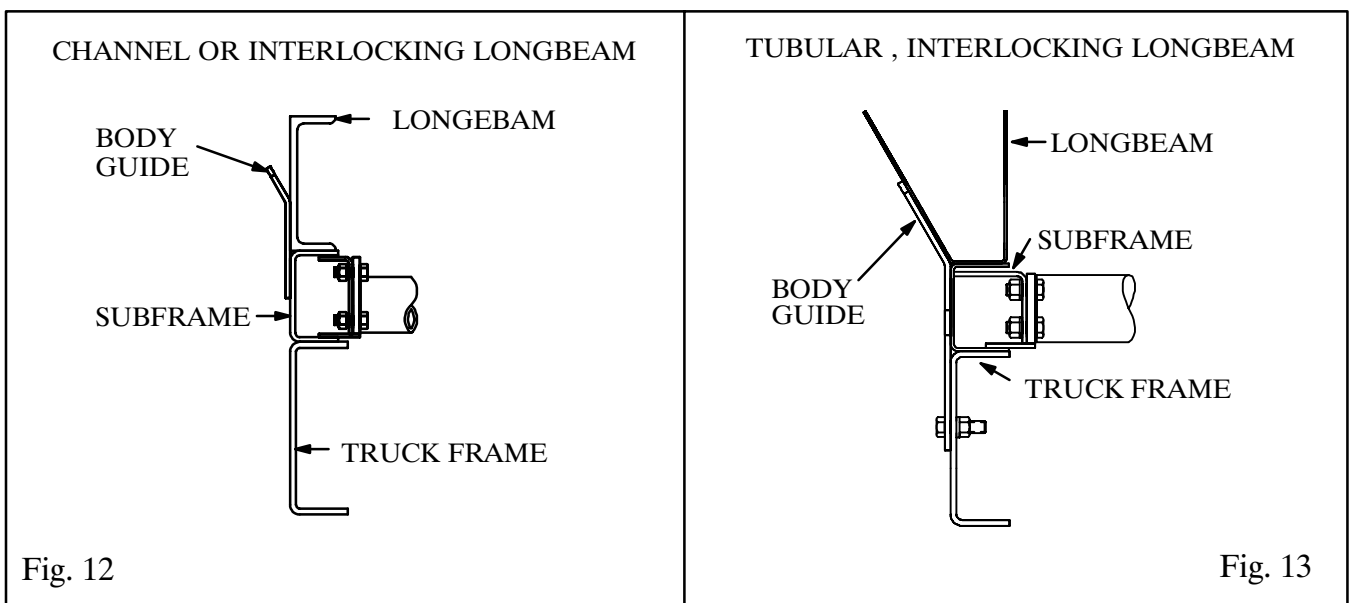

INSTALL BODY PROP LONGBEAM BRACKET – RC540–RC860

The body prop is designed and intended to support an EMPTY truck body in the raised position. Using the body prop permits service work to be performed safely beneath a raised body. It is mounted on the outside of the subframe on the driver's side.

1. Raise the body more than half way up.
2. Raise the prop arm to a free standing position by allowing the prop arm to rest against the rear flange of the prop pivot. The top of the prop arm will swing in under the longbeam.
3. Slowly lower the body until the bottom of the longbeam rests on the body prop saddle. Place the longbeam bracket against the outside of the longbeam so the legs straddle the prop arm saddle. Securely weld this bracket to the body. (See Fig. 14.)
4. To operate the body prop, raise the body to the desired height, shut off all power, raise the prop arm to a free standing position. Lower the body slowly until the longbeam bracket contacts the prop arm saddle. **DO NOT POWER HOIST DOWN!**
5. To place the body prop in the storage position, raise the body to clear the body prop saddle, lower the body prop to the storage position and lower the body.

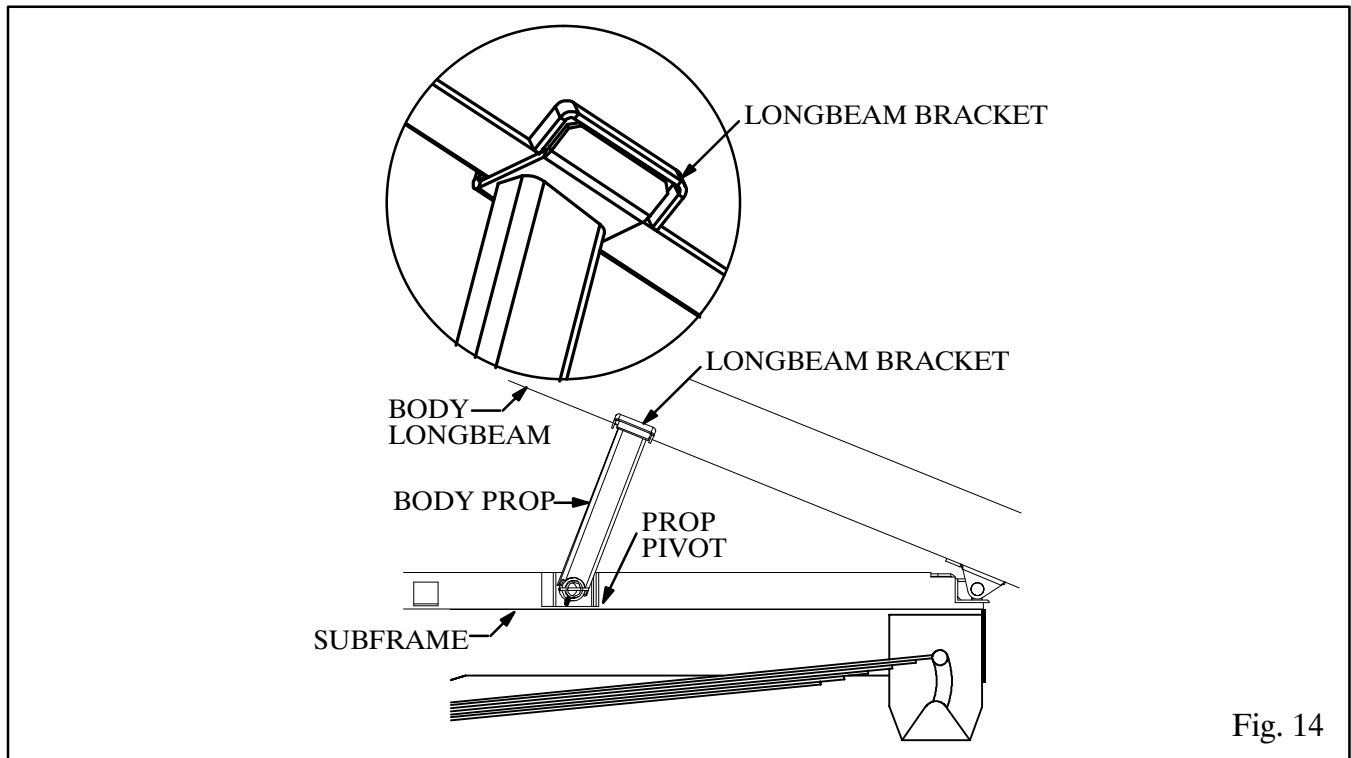

INSTALL BODY PROPS – RC580–RC6100

The body prop is designed and intended to support an EMPTY truck body in the raised position. Use of the body prop permits service to be performed safely beneath a raised body. Two body props (one pair) are included with twin cylinder hoists, Models RC580, RC690 and RC6100. Be sure to install each prop on the correct side of the truck as explained below and shown in Fig. 15.

1. Raise the body to a 30° to 35° angle and brace it securely before beginning installation.
2. Assemble the prop arm to the prop pivot mount with a 1/4 x 3 roll pin. Clamp the prop pivot mount against the outside of the truck frame just behind the rear axle.
3. Raise the body prop arm to a free standing position. Place the body prop bracket in the prop arm saddle. Reposition if needed to locate the prop bracket on the longbeam. It may be necessary to raise or lower the body to get the best location for the prop pivot mount.
4. Using the prop pivot mount as a guide, mark the location of holes on the truck frame and drill 17/32 inch holes. Assemble the prop pivot mount to the frame using 1/2 x 2 cap screws, and hex lock nuts.
5. Raise the prop arm to a free standing position, place the body prop bracket in the saddle and securely weld the bracket to the longbeam.
6. To mount the second prop, repeat steps 2 through 4 for the other side. Use the body prop already mounted to assure that both body props hold the body at the same height. The left and right body props should pivot toward the front of the truck in the storage position.
7. To operate the body prop, raise the body to the desired height, shut off all power, raise the prop arms to a free standing position. Lower the body slowly until the body prop brackets contact the prop arm saddles.
8. To place the body props in the storage position, raise the body to clear the body prop saddles, lower the body props to the storage position and lower the body.

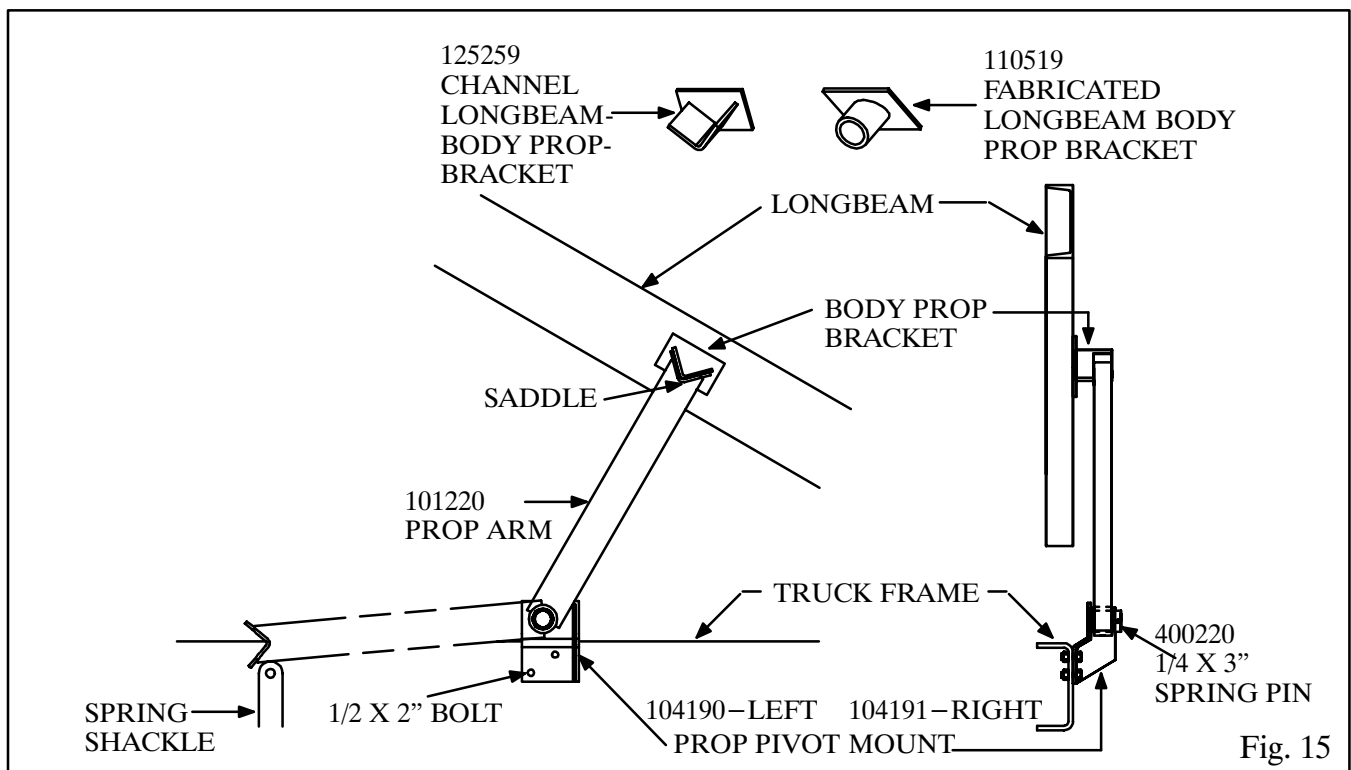

Fig. 15

INSTALL GREASE ZERKS AND LUBRICATE

Install grease zerks in the following locations. Lubricate all fittings at regular intervals, at least every 150 cycles or every two months. The grease fittings are located as follows:

- A. Hoist Lower Crosstube 2 fittings
- B. Cylinder Base Pivot 2 fittings
- C. Body Prop 1 fitting per prop
- D. Rear Hinge 2 fittings
- E. Latch Lever 1 fitting
- F. Tailgate Latch Pivot 2 fittings
- G. Tailgate Hinge Pivot 2 fittings

Lubricate all fittings at regular intervals, at least every 150 cycles or every 2 months. There are extremely high forces on the bearing surfaces within the hoist frame. It pays to be generous in lubricating the hoist to insure proper operation and long life.

PROPER LUBRICATION IS EXTREMELY IMPORTANT!

The center hinge, the cylinder crosshead and the rollers on the Roller–Combo Hoists do not need to be greased. These pivot points are equipped with self lubricating composite bearings that do not need lubrication.

ONE OF THE MOST COMMON REASONS FOR HOIST PROBLEMS IS FAILURE BY THE OPERATOR TO LUBRICATE THE HOIST.

INSTALL LIGHTS, REFLECTORS AND DECALS

Install the lights and wiring harness. Mount the amber reflectors near the front on the sides. Mount the red reflectors near the rear on the sides and on the tailgate near the sides. Slip the rubber hand grip over the end of the latch control lever. **MOUNT DECALS IN THE PROPER PLACES.** See Fig. 16 for decal identification and placement.

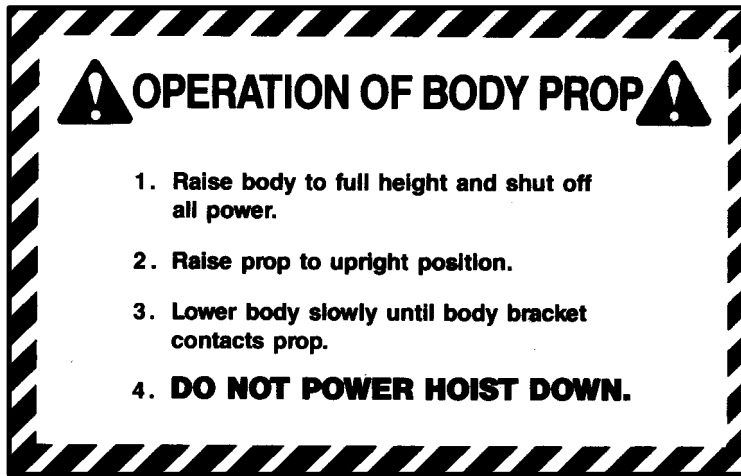

400719 – Mount on the body longbeam near the body prop

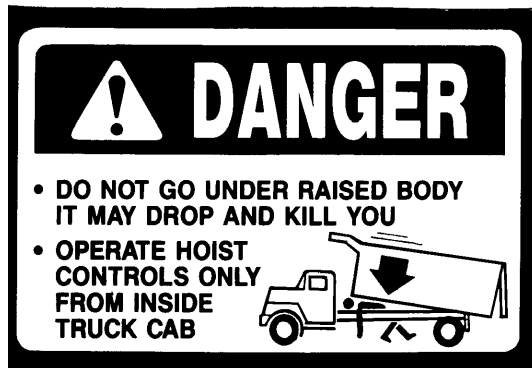

401576 – Mount on the outside of the body longbeams near the front of the body (one on each side).



400643 – Mount on the longbeam on the drivers side.

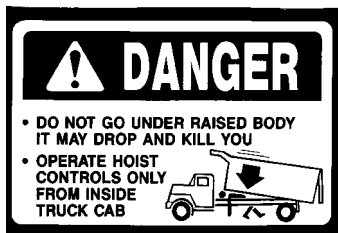

401577 – Mount in the cab in a prominent location

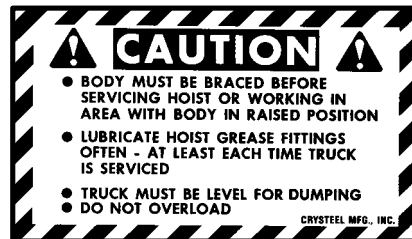

400642 – Mount in the cab in a prominent location



400661 – Mount on the body prop arm.

SINGLE CYLINDER ROLLER-COMBO HOIST PARTS

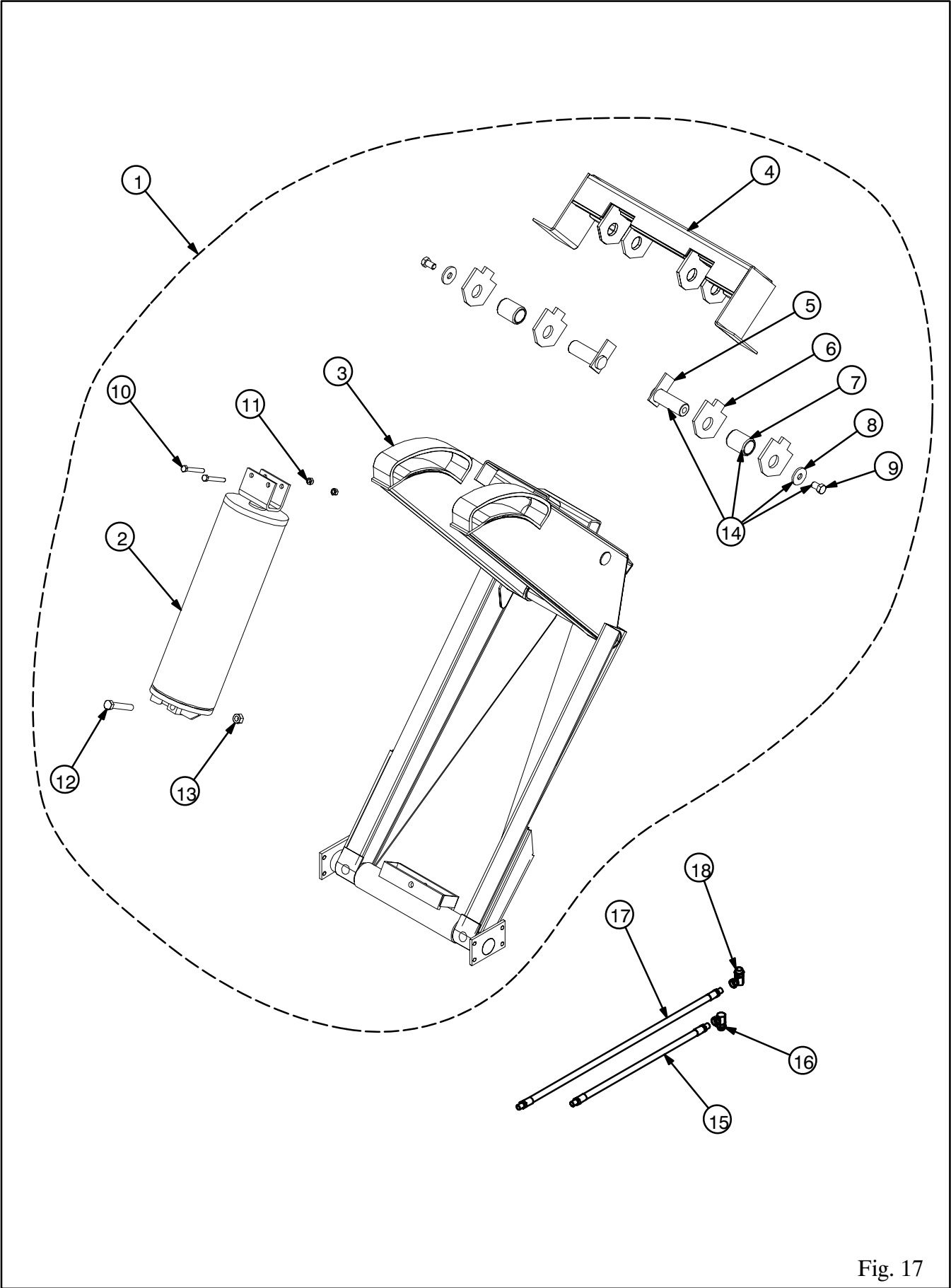

Fig. 17

ITEM	DESCRIPTION	RC540	RC650	RC750	RC860	QTY.
1.	Frame & Cylinder Assy	164373	164374	164375	164375	1
2.	Cylinder Assy	104242	104244	107512	115553	1
3.	Hoist Frame Assy	164377	164377	164377	164377	1
4.	Cross Channel Assy	164380	164380	164380	164380	1
5.	Roller Pin Assy	148209	148209	148209	148209	2
6.	Wear Plate – RC540–RC860	402133	402133	402133	402133	4
7.	Roller 2.375 Diameter	223149	223149	223149	223149	2
8.	Washer 13/16 ID x 2 3/8 OD	402212	402212	402212	402212	2
9.	Cap Screw 3/4–16 x 1 1/4 Grade 8	402183	402183	402183	402183	2
10.	Cap Screw 1/2–13 x 3 3/4 Grade 8	400138	400138	400138	400138	2
11.	Hex Lock Nut 1/2–13	401316	401316	401316	401316	2
12.	Cap Screw 3/4–10 x 4 1/2 Grade 8	401225	401225	401225	401225	1
13.	Hex Lock Nut 3/4–10	401226	401226	401226	401226	1
14.	Roller & Pin Kit (contains 2)	140216	140216	140216	140216	1
15.	Hose 1/2 NPT x 36” 3500 PSI	401293	401293	401293		1
	Hose 3/4 NPT x 36” 2500 PSI				402040	1
16.	Adapter 7/8 ORB x 1/2 NPT 90°	401107	401107	401107		1
	Adapter 1 1/16 ORB x 3/4 NPT				401365	1
17.	Hose 1/2 NPT x 54” 3500 PSI	401294	401294	401294		1
	Hose 3/4 NPT x 60” 2500 PSI				401563	1
18.	Adapter 3/4 ORB x 1/2 NPT 90°	401104	401104	401104		1
	Adapter 7/8 ORB x 3/4 NPT 90°				401477	1

TWIN CYLINDER ROLLER-COMBO HOIST PARTS

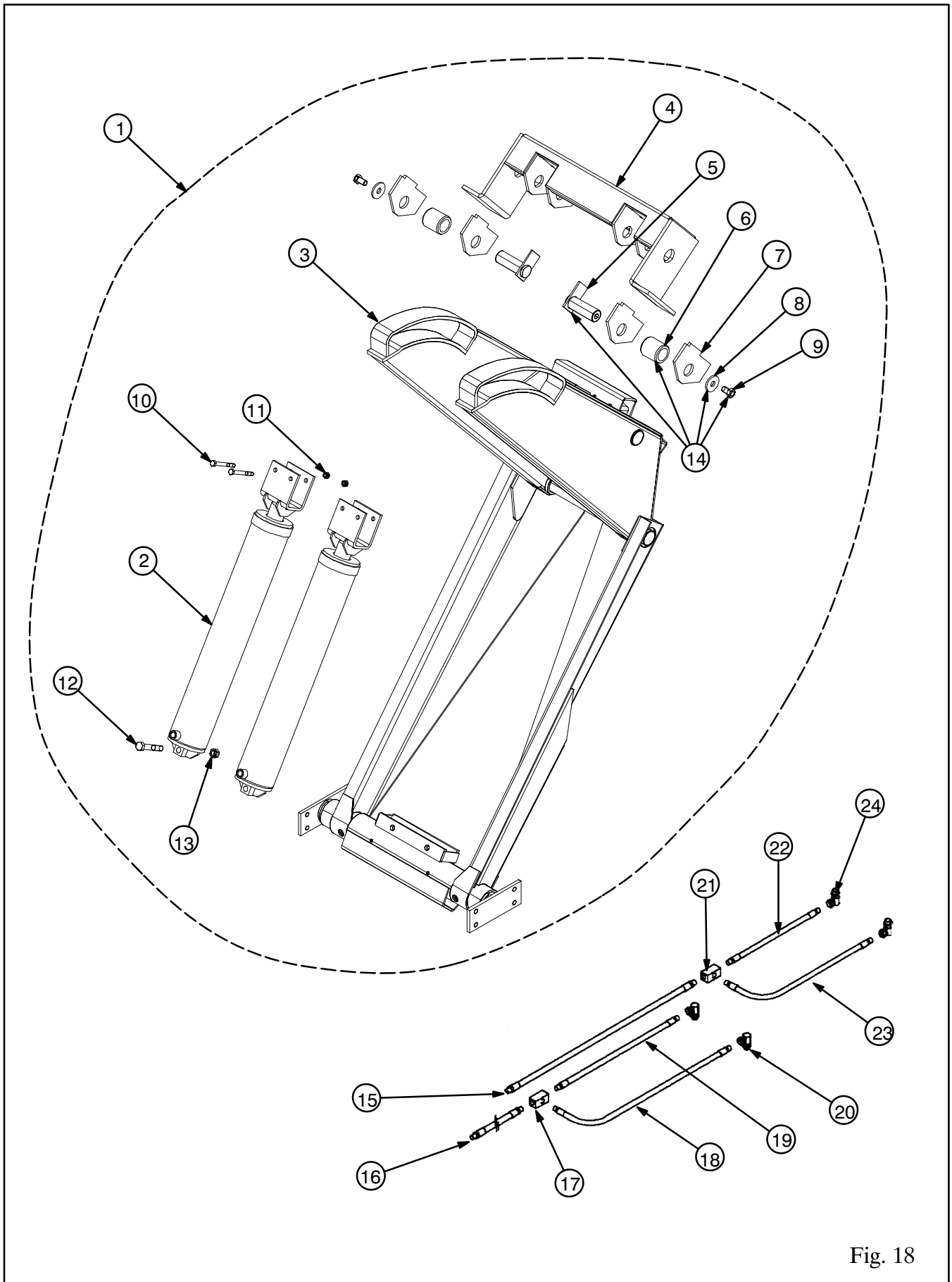

Fig. 18

ITEM	DESCRIPTION	RC580	RC690	RC6100	QTY.
1.	Frame & Cylinder Assy	104207	115451	115451	1
2.	Cylinder Assy	104247	115487	115487	2
3.	Hoist Frame Assy	104210	115452	115452	1
4.	Cross Channel Assy	141391	141392	141392	1
5.	Roller Pin Assy	117630	117630	117630	2
6.	Roller 2.750 Diameter	223835	223835	223835	2
7.	Wear Plate – RC580–RC6100	402186	402186	402186	4
8.	Washer 13/16 ID x 2 3/8 OD	402212	402212	402212	2
9.	Cap Screw 3/4–16 x 1 1/4 Grade 8	402183	402183	402183	2
10.	Cap Screw 1/2–13 x 4 1/2 Grade 8	400135	400135	400135	4
11.	Hex Lock Nut 1/2–13	401316	401316	401316	4
12.	Cap Screw 3/4–10 x 4 1/2 Grade 8	401225	401225	401225	2
13.	Hex Lock Nut 3/4–10	401226	401226	401226	2
14.	Roller & Pin Kit (contains 2)	141393	141393	141393	1
15.	Hose 1/2 NPT–3/4 ORB x 72” 2000 PSI	402142			1
	Hose 3/4 NPT–7/8 ORB x 72” 2000 PSI		401982	401982	1
16.	Hose 1/2 NPT–7/8 ORB x 36” 3500 PSI	401304			1
	Hose 3/4 NPT–7/8 ORB x 36” 2500 PSI		402040		1
	Hose 3/4 NPT–7/8 ORB x 36” 3000 PSI			402480	1
17.	Tee 7/8 ORB	200033	200033	200033	1
	Swivel 7/8 ORB x 3/4 NPT		402079	402079	1
18.	Hose 1/2 NPT–7/8 ORB x 24” 3500 PSI	401303	401303	401303	1
19.	Hose 1/2 NPT–7/8 ORB x 18” 3500 PSI	401302	401302	401302	1
20.	Adapter 7/8 ORB x 1/2 NPT 90°	401107	401107	401107	2
21.	Tee 3/4 ORB	200031	200031	200031	1
	Swivel 3/4 ORB x 3/4 NPT		401518	401518	1
22.	Hose 1/2 NPT–3/4 ORB x 12” 3500 PSI	401298	401298	401298	1
23.	Hose 1/2 NPT–3/4 ORB x 18” 3500 PSI	401299	401299	401299	1
24.	Adapter 3/4 ORB x 1/2 NPT 90°	401104	401104	401104	2

SINGLE CYLINDER ROLLER-COMBO SUBFRAME PARTS

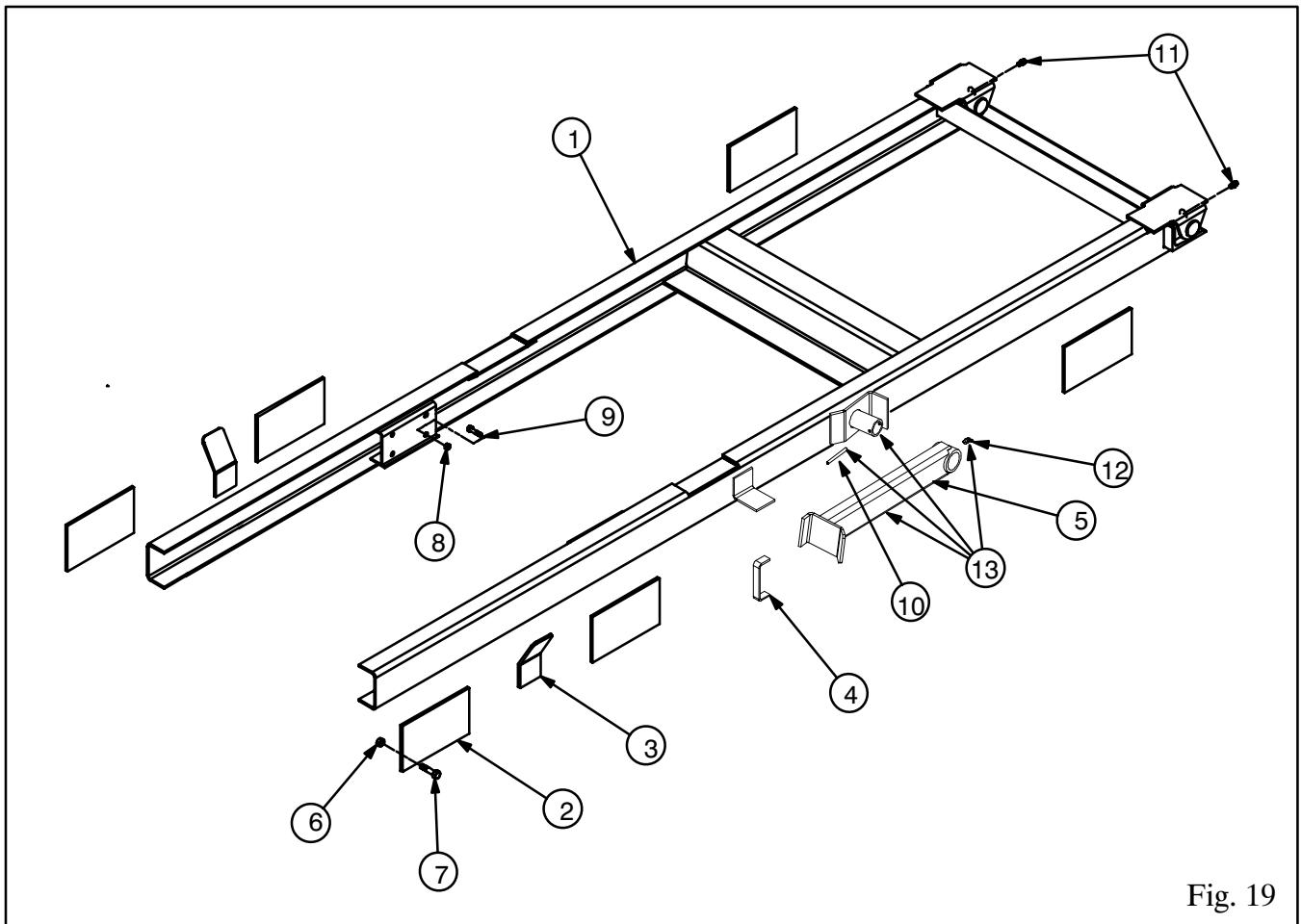

Fig. 19

ITEM	DESCRIPTION	RC540	RC650	RC750	RC860	QTY.
1.	Subframe Assy – 8'		162477			1
	Subframe Assy – 9'		162478			1
	Subframe Assy – 10'		162485			1
	Subframe Assy – 11'		162495			1
	Subframe Assy – 12'		162499			1
2.	Mounting Plate		227988			6
3.	Body Guide		222812			2
4.	Body Prop Longbeam Bracket		276942			2
5.	Body Prop Arm Assy		152016			1
6.	Hex Lock Nut 5/8-11		401582			12
7.	Cap Screw 5/8-11 x 2 Grade 8		402374			12
8.	Hex Lock Nut 1/2-13		401316			8
9.	Cap Screw 1/2-13 x 1 1/4 Grade 8		400153			8
10.	Roll Pin 1/4 x 3		400220			1
11.	Grease Zerk 1/8 NPT		400103			2
12.	Grease Zerk 1/8 NPT 90°		400117			1
13.	Body Prop Kit		152014			1

TWIN CYLINDER ROLLER – COMBO SUBFRAME PARTS

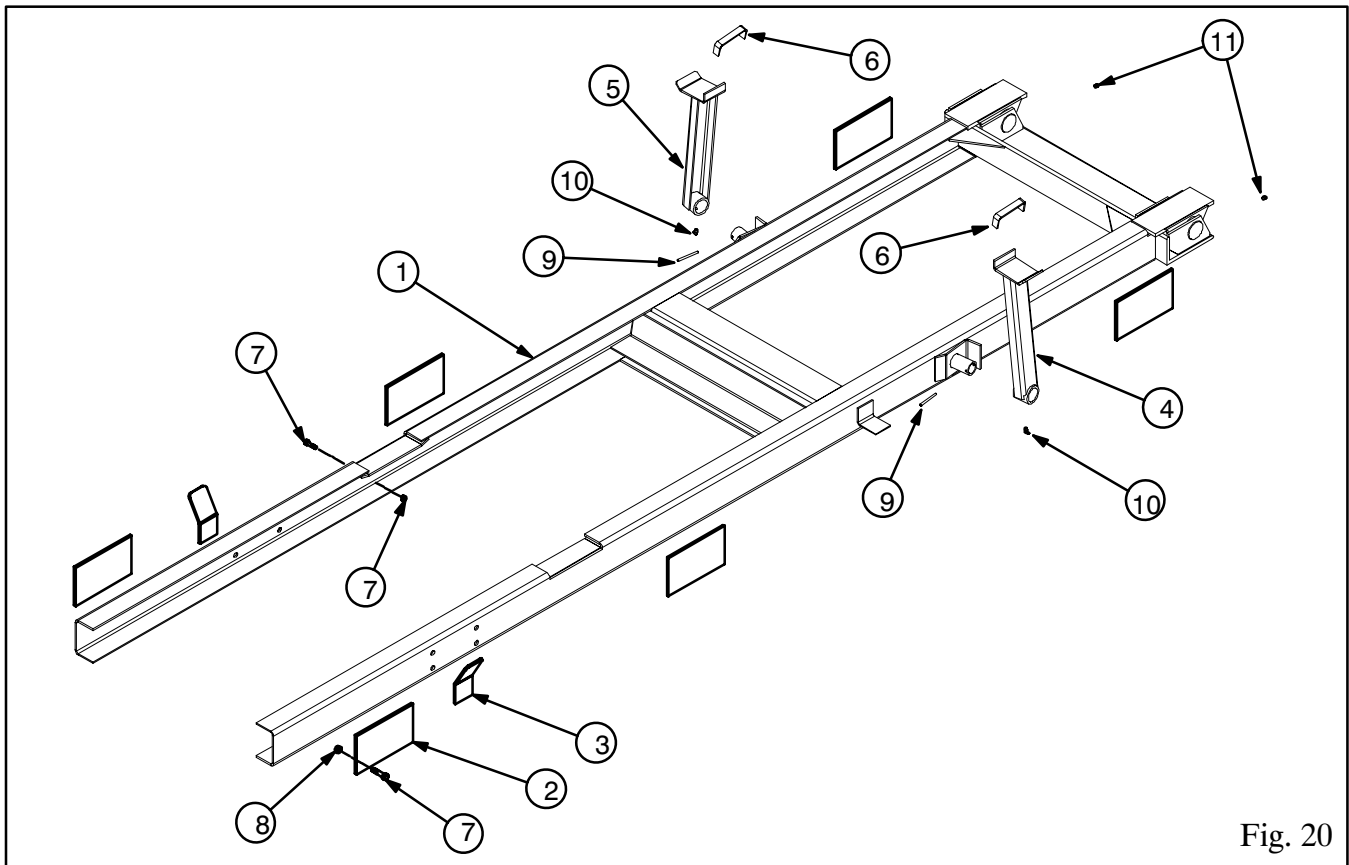

Fig. 20

ITEM	DESCRIPTION	RC580	RC690	RC6100	QTY.
1.	Subframe Assy – 12'	151777	160311		1
	Subframe Assy – 13'	105733	160310		1
	Subframe Assy – 14'	151779	159757		1
	Subframe Assy – 15'	104952	260312		1
	Subframe Assy – 16'	151781	160313		1
2.	Mounting Plate		227988		6
3.	Body Guide		222812		2
4.	Body Prop Arm Assy – Left		152016		2
5.	Body Prop Arm Assy – Right		152017		1
6.	Bracket Longbeam Prop		276942		1
7.	Cap Screw 5/8–11 x 2 Grade 8		402374		1
8.	Hex Lock Nut 5/8–11		401582		12
9.	Roll Pin 1/4 x 3		400220		2
10.	Grease Zerk 1/8 NPT 90°		400117		2
11.	Grease Zerk 1/8 NPT		400103		2
12.	Hex Lock Nut 1/2–13		401316		8
13.	Body Prop Kit – Left		152014		
14.	Body Prop Kit – Right		152015		

ROLLER-COMBO HYDRAULICS PARTS

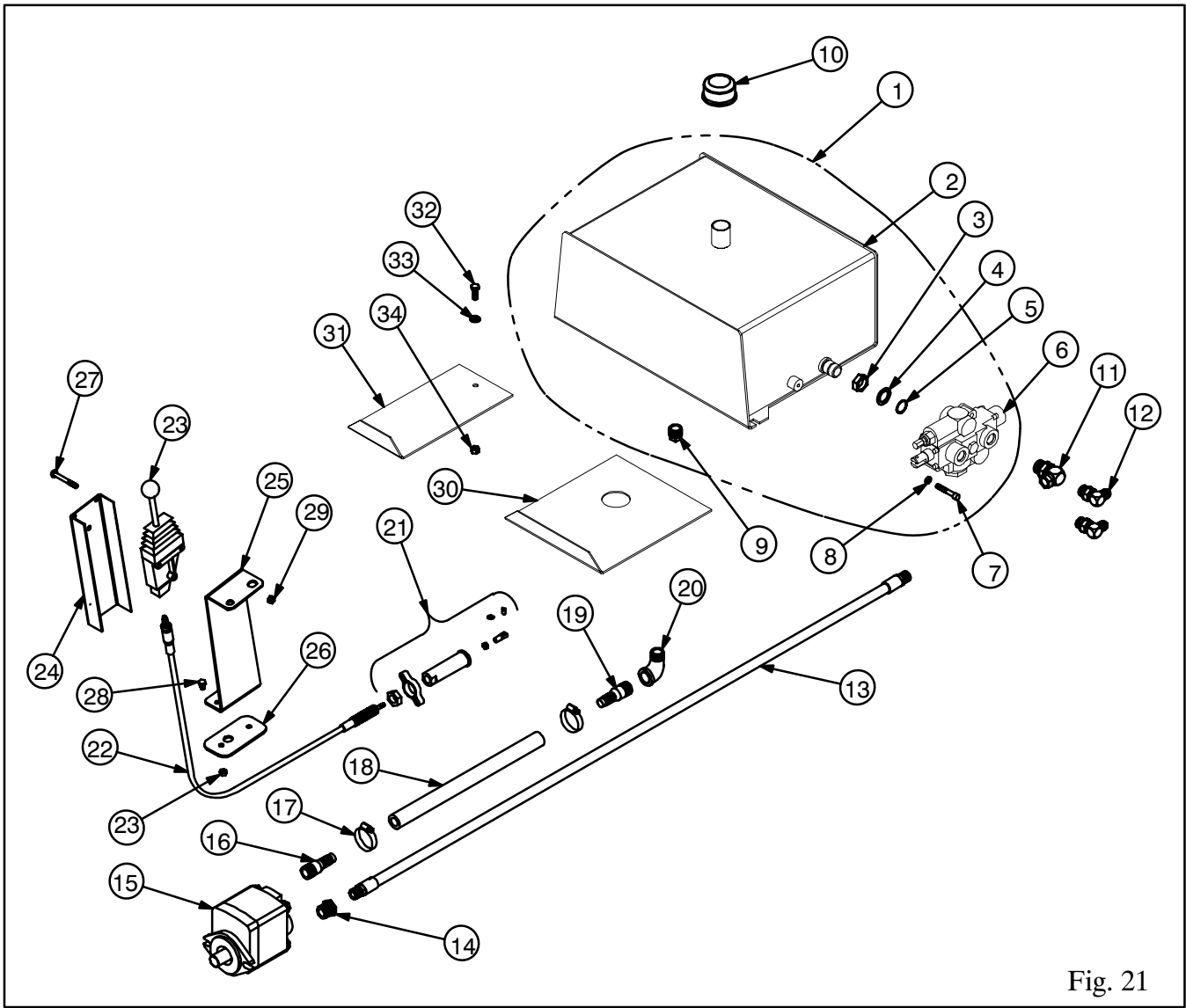

Fig. 21

ITEM	DESCRIPTION	HOIST MODEL	PART NO.	QTY.
1.	Reservoir/Valve Assy 10 Gal 3250 PSI	RC540-RC650	116367	1
	Reservoir/Valve Assy 10 Gal 2000 PSI	RC750-RC860	116634	1
	Reservoir/Valve Assy 18 Gal 3250 PSI	RC580	116369	1
	Reservoir/Valve Assy 18 Gal 2000 PSI	RC690	116637	1
	Reservoir/Valve Assy 18 Gal 2700 PSI	RC6100	118951	1
2.	Reservoir Weldment 10 Gal	RC540-RC860	116368	1
	Reservoir Weldment 10 Gal	RC580-RC6100	116370	1
3.	Hex Jam Nut 1 1/16-12	All	402092	1
4.	Cone Washer 1 1/16	All	402093	1
5.	O-Ring .924 ID x .116 CS	All	401094	1
6.	Control Valve 3250 PSI -10 Port	RC540, RC650, RC580	402065	1
	Control Valve 2000 PSI -10 Port	RC750-RC860	402067	1
	Control Valve 2000 PSI -12 Port	RC690	402105	1
	Control Valve 2700 PSI -12 Port	RC6100	402481	1

7.	Soc Cap Screw 5/16–18 x 2	All	402115	1
8.	Lock Washer 5/16	All	400165	1
9.	Magnetic Pipe Plug 3/4"	All	400405	1
10.	Breather Cap	All	400764	1
11.	Adapter 1 1/16 ORB x 1/2 NPT 90°	RC540–RC750, RC580	401285	1
	Adapter 1 1/16 ORB x 3/4 NPT 90°	RC860, RC690–RC6100	401291	1
12.	Adapter 7/8 ORB x 1/2 NPT 90°	RC540–RC750, RC580	401107	2
	Adapter 7/8 ORB x 3/4 NPT 90°	RC860	401477	2
	Adapter 1 1/16 ORB x 3/4 NPT 90°	RC860	401477	2
13.	Hose 1/2 NPT x 72" 3500 PSI	RC540–RC750, RC580	401447	1
	Hose 3/4 NPT x 72" 2500 PSI	RC860, RC690	401982	1
	Hose 3/4 NPT x 72" 3000 PSI	RC6100	401937	1
14.	Hex Bushing 3/4 NPT x 1/2 NPT	RC540–RC650	401091	1
	Adapter 1 5/16 ORB x 1/2 NPT	RC750, RC580	210608	1
	Adapter 1 5/16 ORB x 3/4 NPT	RC860, RC690–RC6100	219825	1
15.	Pump 6 GPM P20	RC540–RC650	400394	1
	Pump 10 GPM P20	RC750–RC580	402344	1
	Pump 15 GPM P20	RC860, RC690–RC6100	402113	1
16.	Hose Barb 3/4 NPT x 3/4	RC540–RC650	401447	1
	Hose Barb 1 5/16 ORB x 1 1/4	RC750–RC6100	401450	1
17.	Hose Clamp #24 1 1/16–2	RC540–RC650	401441	2
	Hose Clamp 1 3/4 T–Bolt	RC750–RC6100	402164	2
18.	Suction Hose 3/4 ID x 72"	RC540–RC650	210604	1
	Suction Hose 1 1/4 ID x 72"	RC750–RC6100	210606	1
19.	Hose Barb 3/4 NPT x 3/4	RC540–RC650	401447	1
	Hose Barb 1 1/4 NPT x 1 1/4	RC750–RC6100	401449	1
20.	Street Elbow 3/4 90°	RC540–RC650	402144	1
	Street Elbow 1 1/4 90°	RC750–RC6100	401296	1
21.	Valve Connection Kit	All	402127	1
22.	Control Cable 84"	All	402419	1
23.	Valve Control	All	402120	1
24.	Channel, Tall Pedstal	All	223397	1
25.	Pedestal, Tall	All	223396	1
26.	Clamp Plate, Pedestal	All	225127	1
27.	Machine Screw 5/16–18 x 2 1/2	All	402154	3
28.	Cap Screw 5/16–18 x 1/2 HH	All	402415	2
29.	Hex Lock Nut 5/16–18	All	401240	5
30.	Reservoir Mount, Left (large)	All	223626	1
31.	Reservoir Mount, Right (small)	All	223627	1
32.	Cap Screw 3/8–16 x 1	All	400121	4
33.	Flat Washer 3/8	All	400164	4
34.	Hex Lock Nut 3/8–16	All	402038	4

ROLLER-COMBO CYLINDER PARTS

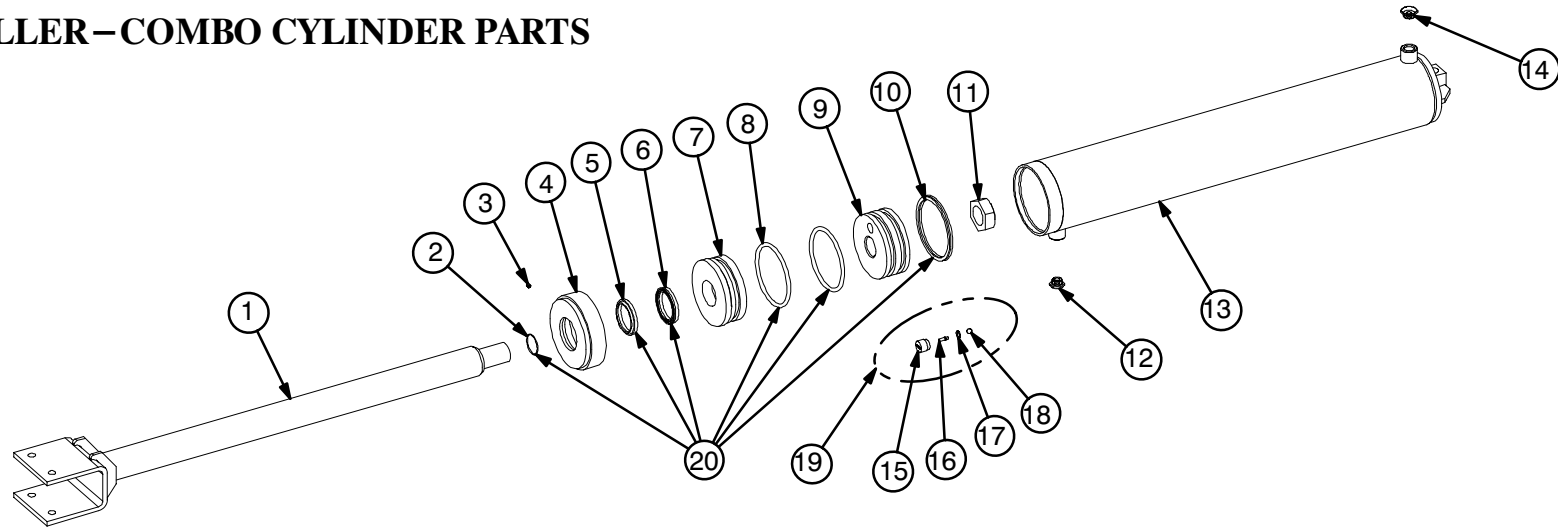

Fig. 22

Item	Description	RC540	RC650	RC750	RC860	RC580	RC690	RC6100	Qty
1.	Cylinder Shaft Assy	104321	104323	104323	115617	104334	104340	104340	1
2.	O-Ring	400255	400255	400255	402051	400255	400255	400255	1
3.	Set Screw 1/4 x 3/16	400149	400149	NONE	NONE	400149	NONE	NONE	1
4.	Cap Assy	104293	104299	NONE	NONE	104294	NONE	NONE	1
5.	Wiper	400913	400914	400914	400914	400914	400915	400915	1
6.	Shaft Seal	400253	400907	400907	400907	400907	400908	400908	1
7.	Cylinder Head	202469	205141	223373	221457	205145	221937	221937	1
8.	O-Ring	400254	400258	401281	402000	400254	400258	400258	2
9.	Cylinder Piston	202461	202472	209185	221456	202461	202472	202472	1
10.	Piston Seal	400252	400257	401282	402001	400252	400257	400257	1
11.	Hex Jam Nut	401370	401370	401370	NONE	401370	401370	401370	1
12.	Plug, Nylon	401389	401389	401389	401390	401389	401389	401389	1
13.	Cylinder Tube Assy	104316	102035	116881	115407	104329	115488	115488	1
14.	Plug, Nylon	401390	401390	401390	401582	401390	401390	401390	1
15.	Bypass Valve Body	400978	400978	400978	400978	400978	400978	400978	1
16.	Bypass Valve Pin	400979	400979	400979	400979	400979	400979	400979	1
17.	Steel Ball 3/8 Dia	400013	400013	400013	400013	400013	400013	400013	1
18.	O-Ring	401017	401017	401017	401017	401017	401017	401017	1
19.	Bypass Valve Kit	105185	105185	105185	105185	105185	105185	105185	1
20.	Seal Kit	107960	107962	107963	141390	107960	107962	107962	1
21.	Cylinder Assy	104242	104244	107512	115553	104247	115487	115487	1

NOTES

NOTES

SPECIALLY DESIGNED – WITH QUALITY IN MIND

CUSTOMER SATISFACTION PLEDGE

Crysteel's Customer Satisfaction Pledge is designed to be the most comprehensive warranty in the truck equipment industry. This pledge covers new products for a period of five (5) years, and is not restricted by vehicle mileage or when product is invoiced to our distributors. Our warranty begins when our product is put into service by the final customer.

This warranty covers our products for defective material and/or workmanship at a rate of 100 % for the first (3) years and at a rate of 50 % for years 4 and 5. This warranty covers:

- Crysteel Manufactured product
- OEM Products purchased by Crysteel as part of our product
- The repair of warranted product
- The replacement of warranted product
- Labor to replace warranted product
- Freight for replacement product
- Warranted product return freight (if required)

This warranty is limited to product supplied under the Crysteel Mfg. name and does not cover distributor modifications. Repair or replacement is at Crysteel's option. Primer warranty is limited to adherence to metal surfaces only and does not include the inside or understructure of dump bodies. Crysteel will not assume responsibility for travel, loss of use, downtime expenses or other incidental or consequential damages. This warranty is void if the product has been obviously abused or subjected to other than normal usage. There are no other warranties except as described above, and Crysteel makes no warranty of fitness for a particular purpose.

! CAUTION !

- **BODY MUST BE BRACED BEFORE SERVICING HOIST OR WORKING IN AREA WITH BODY IN RAISED POSITION**
- **LUBRICATE HOIST GREASE FITTINGS OFTEN – AT LEAST EACH TIME TRUCK IS SERVICED**
- **TRUCK MUST BE LEVEL FOR DUMPING**
- **DO NOT OVERLOAD**

CRYSTEEL MFG, INC.

CRYSTEEL MANUFACTURING, INC.

P.O. Box 178 52182 Ember Road
Lake Crystal, MN 56055

1902 Route 57 South
Fulton, NY 13069

(507) 726-2728 (800) 533-0494