

CRYSTEEL'S STINGRAY HOIST



P.O. Box 178
52182 Ember Road
Lake Crystal, MN 56055

www.crysteel.com
crysteel@crysteel.com
(507) 726-2728 (800) 533-0494

1902 Route 57 South
Fulton, NY 13069

DATE PURCHASED

BODY SERIAL NUMBER

HOIST SERIAL NUMBER

CYLINDER SERIAL NUMBER

DEALER

ADDRESS

PHONE

FOREWORD

The Stingray twin cylinder underbody hoist is designed for use on single and tandem axle trucks with 12 to 28 foot bodies. The Stingray line provides hoists ranging from Model 1500 in NTEA class E/50 to the Model 7700 in NTEA class L/120.

This manual contains the information needed for the proper installation and operation of these hoists.

These instructions are for standard installations using a self contained reservoir/valve unit. Study this manual carefully before attempting to install or

operate this product. Other hydraulic packages will come with supplemental instruction sheets when needed. With the proper installation, use and regular maintenance, Crysteel's Stingray hoist will give many years of trouble free service.

When ordering parts, be sure to give serial number of hoist, pump, and cylinder. The serial number of the pump is found on the plate on the pump. The serial number of the cylinder is stamped on the barrel of the cylinder near the base. For future reference, copy these numbers NOW in the space provided above. Order parts by number and description as given in the parts listing in this manual.

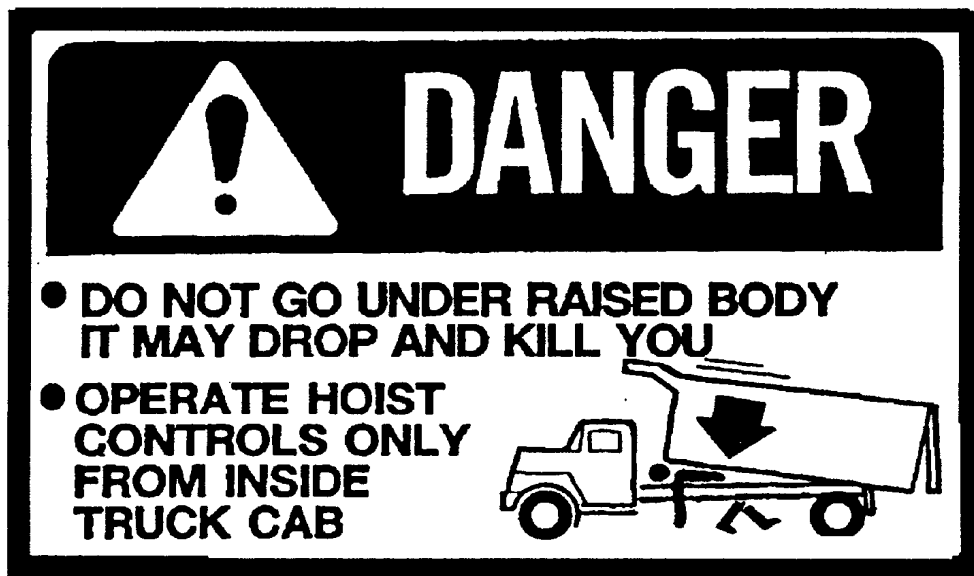

OPERATION AND USE

1. Engage PTO from cab and adjust engine speed to fast idle.
2. The hoist should raise when the hoist control lever is pulled back, hold when the lever is in the center detent, and lower when the lever is pushed forward.
3. To raise the hoist, pull the control lever back. To hold the body in a raised position, place the control lever in its center detent position. To lower the hoist, push the control lever forward.
4. **ALWAYS** return the hoist control lever to its center detent position after each use.
5. **DO NOT LEAVE THE PTO IN GEAR WHILE TRANSPORTING. THIS CAN CAUSE SEVERE DAMAGE TO THE PTO OR HYDRAULIC PUMP/VALVE.**
6. The hydraulic system should be drained, flushed and refilled with proper hydraulic fluid at regular intervals. **CAUTION: NEVER use hydraulic BRAKE FLUID in the hydraulic system.**

SOME DO'S AND DON'TS FOR SAFE AND LONG SERVICE

1. Use the proper hydraulic fluid. **KEEP IT CLEAN.** Remember to change it regularly.
2. Lubricate all grease fittings at regular intervals.
3. **ALWAYS** carefully block up the body, using the body prop, before working under it.
4. Do not “race” the engine when unloading.
5. Do not load the hoist beyond its capacity.
6. **DO NOT** tamper with the hydraulic relief valve. This will void the warranty. It can cause severe damage to the hoist and cylinder.
7. Never leave the PTO in gear while transporting. It could ruin the hydraulic pump, the PTO or the transmission.
8. Check all bolts and fittings regularly. Keep them tight.

TABLE OF CONTENTS

Purchase Record	1
Foreword	1
Operation and Use	2
Some Do's and Don't's	2
Table of Contents	3
Complete Cylinder Installation	4–5
Mount Rear Hinge	6
Locate Hoist on Truck Frame	6
Mount Hoist to Truck Frame	6
Mount Gear Pump	7
Mount Reservoir/Valve	9
Install Remote Valve Control	9
Install Hoses 1500–1900	10
Install Hoses 3300 & 4400 Single–Acting	10
Install Hoses 5500, 6600, 7700 Single–Acting	10
Install Hoses 3300 & 4400 Double–Acting	10
Install Hoses 5500, 6600, 7700 Double–Acting	10
Add Hydraulic Oil	12
Mount Body	12
Install Body Guides	13
Install Body Props	14
Install Grease Zerks and Lubricate	15
Install Decals	15
Routine Maintenance	17
Parts Lists and Diagrams	18–20

INSTALLATION INSTRUCTIONS

COMPLETE CYLINDER INSTALLATION

Place the hoist upside down on the floor. The cylinders have been installed in the cylinder mounting sleeves. They need to be bolted to the crossheads.

On **DOUBLE-ACTING CYLINDERS** the head ports should be toward the center of the hoist for hoist models 3300 through 7700. Lift the base end of the cylinders to align the cylinders with the crossheads. (The hoist may need to be opened slightly to do this.) Bolt the cylinders to the crossheads using 3/8 x 1 1/2 cap screws, lock washers and hex nuts. Check the cylinder mounting screws; they should be tight.

On **SINGLE-ACTING CYLINDERS** bolt the cylinders to the crosshead using 3/8 x 1 1/2 capscrews, and hex locknuts. (The hoist may

need to be opened slightly to do this.) Check the cylinder mounting screws, they should be tight.

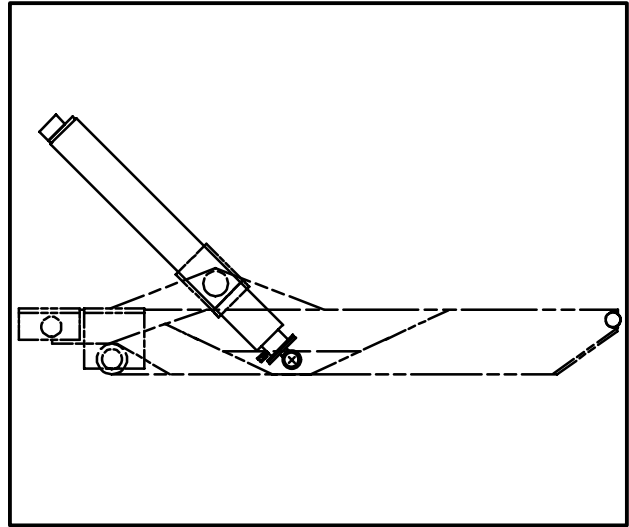

MOUNT THE REAR HINGE

The rear hinge must be located as close as possible behind the rear spring hanger. This will be 32 to 36 inches behind the center of the rear axle on single axle trucks and 42 to 50 inches behind the center of the tandem on tandem axle trucks. Mark the rear of the truck frame for notching as shown, leaving enough of the bottom flange of the truck frame to be bent up later to box in the truck frame. Notch the truck frame as marked. Make sure the rear hinge is square with the truck frame and at the correct height. The top surface of the rear hinge bracket should be flush with the top of the angle mounting brackets of the hoist frame. Securely weld the rear hinge to the truck frame. Bend the bottom flange of the truck frame up and weld all around to box in the truck frame.

the gusset does not interfere with the rear hinge operation. Securely weld the gussets to the rear hinge, the truck frame rail and the top flange of the truck frame rail.

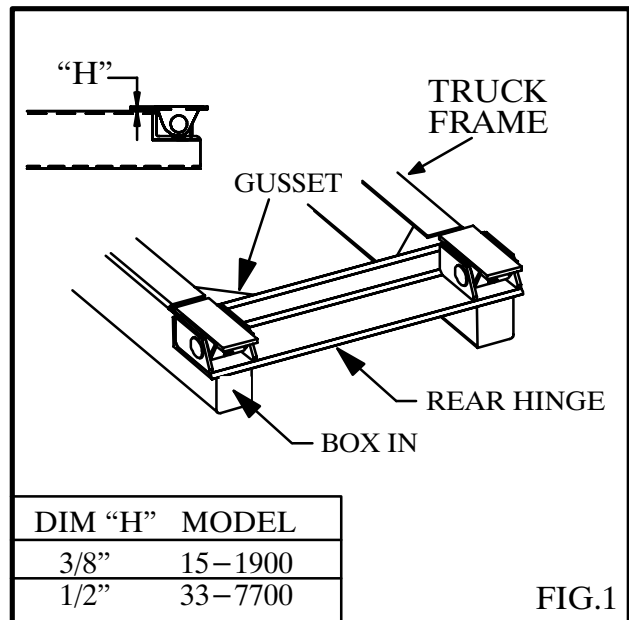

FIG.1

Place the gussets in the corners formed by the truck frame rail and the rear hinge frame angle. Raise the front end of the gusset so it touches the top flange of the truck frame rail. Be sure that

LOCATE HOIST ON TRUCK FRAME

Find the “D” dimension in TABLE 1, on page 6, for the hoist model and desired dump angle. Using this dimension, measure forward from the center of the rear hinge and mark the truck frame. Place the hoist on the truck frame. (See Fig. 2) Center the front cross tube of the hoist over the mark on the truck frame. Be sure to allow enough room for the cylinders to swing as the body is raised. Make sure the hoist is centered on and square with the truck frame. The angle mounting brackets must rest flat on the truck frame. If rivets are encountered in the truck frame, and the hoist cannot be moved to

clear them, countersink the rivet heads into the brackets. The rear end of the main hoist frame is designed to rest on a crossmember in the truck frame. If no crossmember exists to support the hoist frame, add one.

Note: In some cases the hoist may fit the truck frame better if it is mounted reversed or “backwards” as shown in Figure 3. When mounting the hoist “backwards” be sure to measure to the front crosstube of the hoist as shown in Figure 3 and to allow enough room for the cylinders to swing as the body is raised.

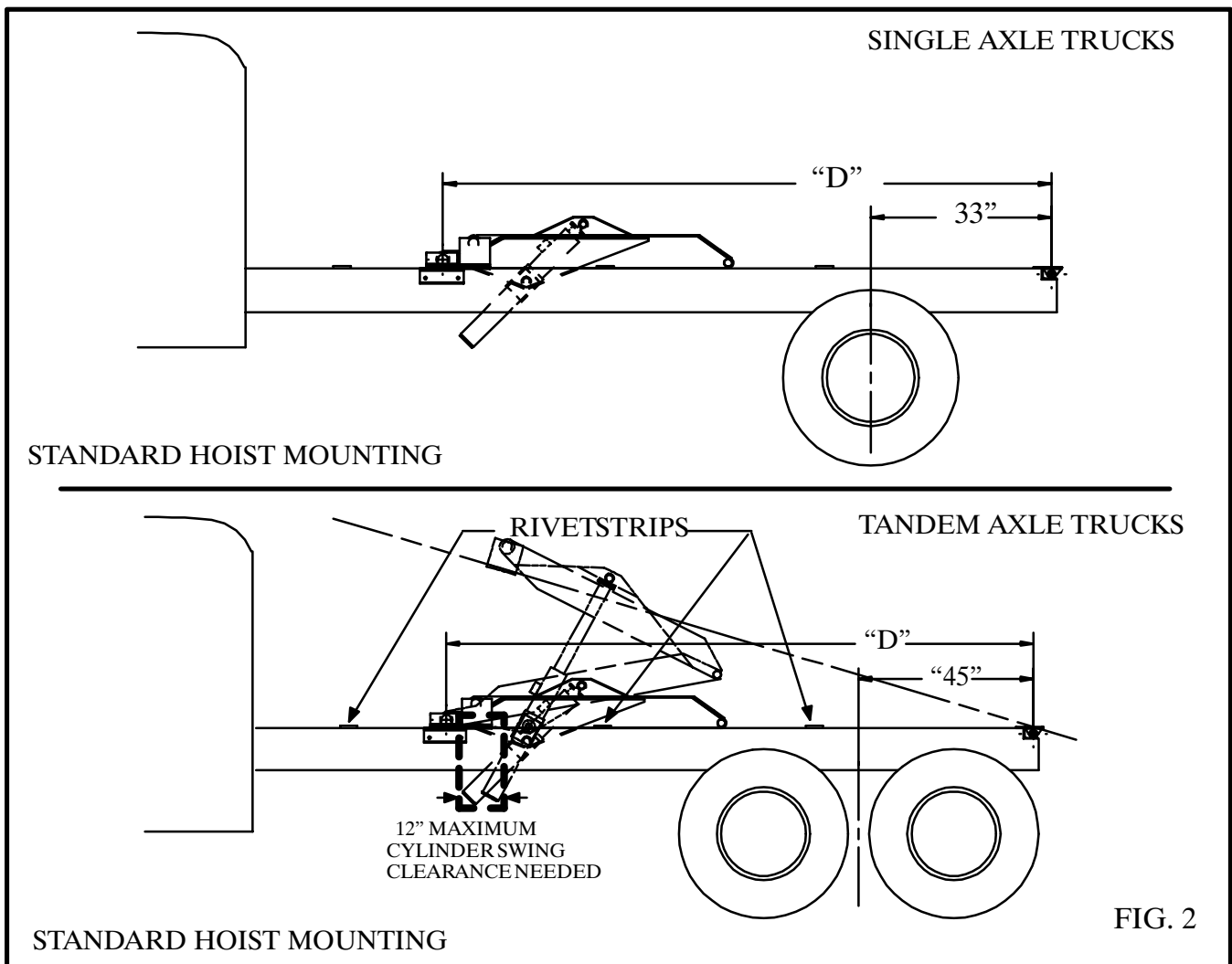

NOTE: NO CROSSBRACING allowed within cylinder swing clearance area. Crossbracing will lead to interference with the working operation of the hoist. (Fig. 2 and 3 on the Tandem Axle Trucks.)

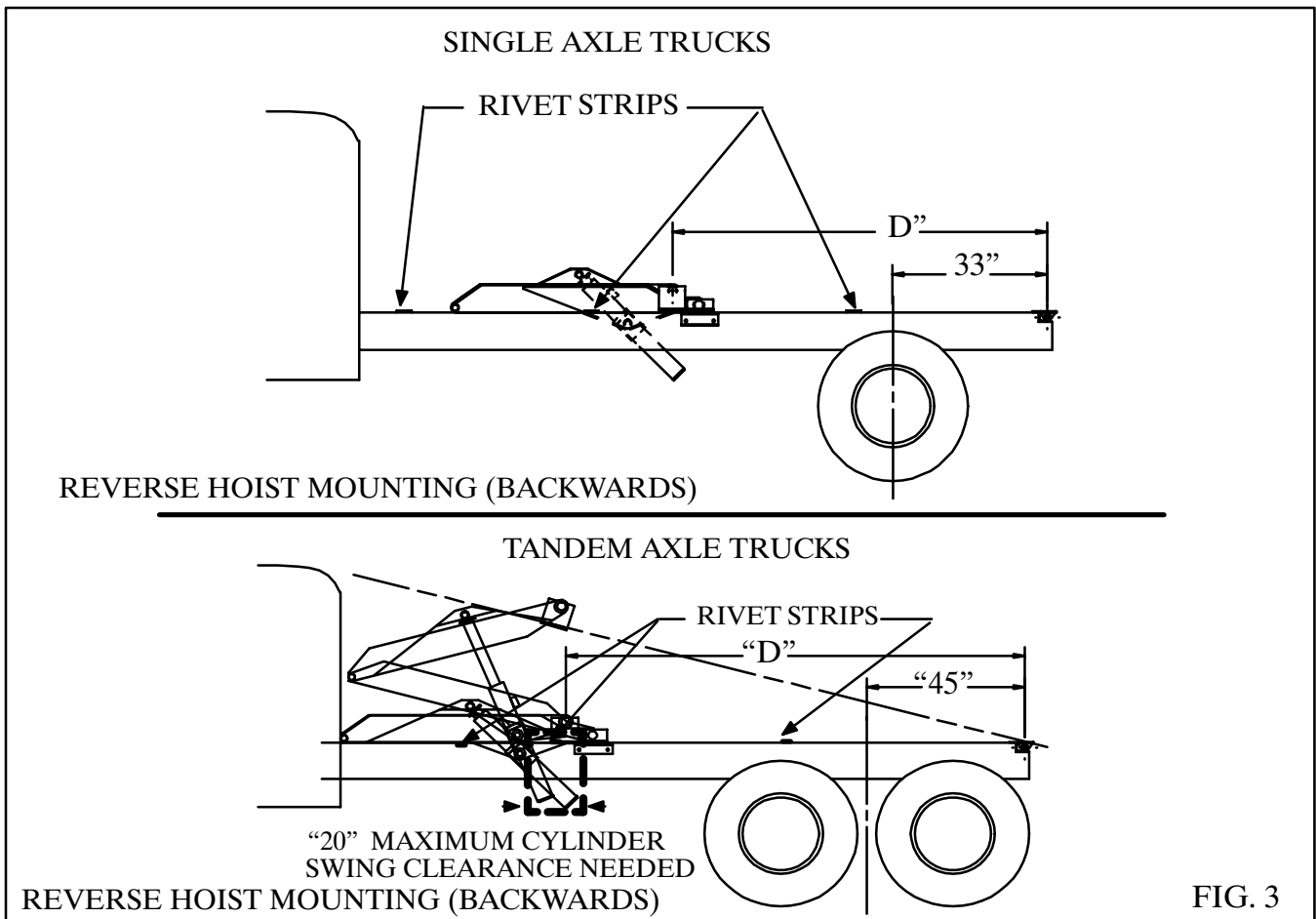

TABLE 1

MODEL	DUMP ANGLE			
	40°	45°	50°	55°
1500	113"	97"	88"	81"
1900	113"	97"	88"	81"
3300	136"	123"	111"	102"
4400	136"	123"	111"	102"
5500	171"	153"	140"	128"
6600	191"	171"	156"	143"
7700	208"	186"	169"	155"

MOUNT HOIST TO TRUCK FRAME

Center the mounting angles under the angle mounting brackets on the hoist. Clamp them in place and mark the truck frame for drilling, using the mounting angles as guides. (See Fig. 4)

CAUTION: WHEN DRILLING THE TRUCK FRAME BE CAREFUL OF BRAKELINES, WIRING, ETC, INSIDE THE TRUCK FRAME.

Drill $21/32$ inch holes in the truck frame and bolt the mounting angles in place using $5/8 \times 1\ 3/4$ cap screws, lock washers and hex nuts. Securely weld the angle mounting brackets to the mounting angles.

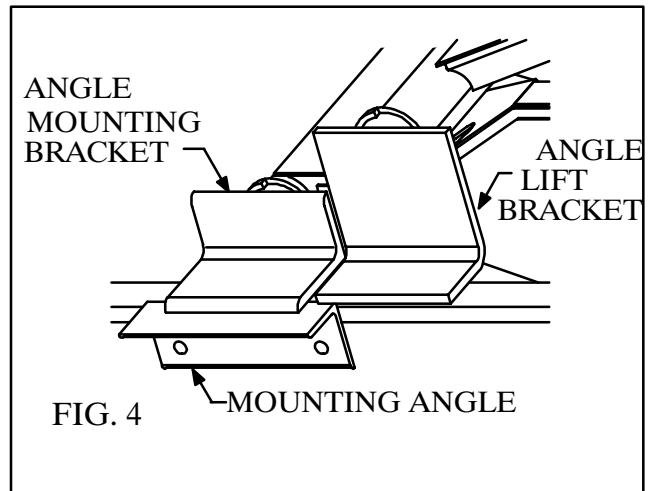

MOUNT GEAR PUMP

The gear pump has an SAE 'B' mounting configuration, a 13-tooth splined shaft and a four-bolt mounting flange, and is assembled for rotation in either direction. *NOTE:* This pump will mount directly to Chelsea's output type 'XK' or Muncie's output type 'D'. Crysteel Manufactur-

ing recommends a PTO ratio of 100–120%. This assures a minimum pump operating speed of 600 RPM. Bolt the gear pump to the PTO output flange using $1/2 \times 1\ 1/4$ " cap screws and lock washers.

MOUNT RESERVOIR/VALVE ASSEMBLY

The reservoir/valve assembly should be mounted on the same side of the truck as the pump with the exposed end of the valve spool toward the front. Bolt the mounting angles to the reservoir/valve assembly using $3/8 \times 1$ cap screws, flat washers, lock washers and hex nuts. Place the valve/reservoir assembly inside the truck frame and raise it as high as possible. See Fig. 5. (There is no drive line to align and the res-

ervoir should be higher than the pump for reliable performance.) Make sure there is enough clearance for the truck drive line and hot exhaust pipes. **THE ENGINE EXHAUST MUST NEVER BLOW DIRECTLY ONTO THE RESERVOIR/VALVE ASSEMBLY.** Clamp the mounting angles to the truck frame and mark the truck frame for drilling using the pump mounting angles as guides.

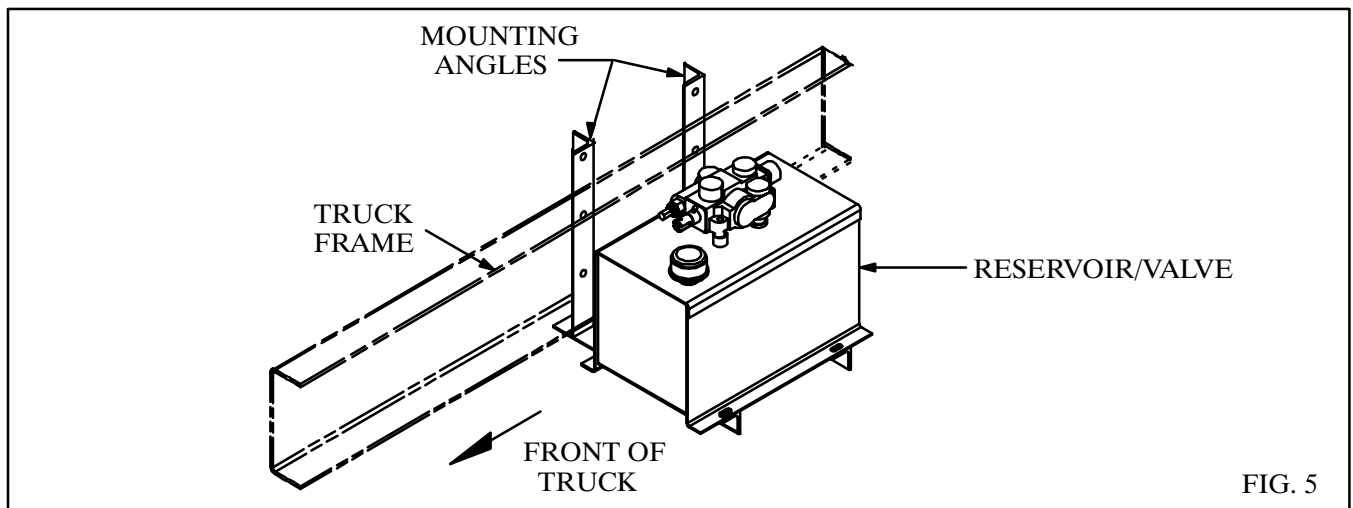

CAUTION: WHEN DRILLING THE TRUCK FRAME BE CAREFUL OF BRAKELINES, WIRING, ETC. INSIDE THE TRUCK FRAME .

Drill 17/32” holes in the truck frame and bolt the reservoir/valve assembly in place using 1/2 x 1 3/4” cap screws, lock washers and hex nuts.

INSTALL REMOTE VALVE CONTROL

Temporarily assemble the valve control head to the pedestal using 5/16 x 2 1/4” machine screws and hex nuts. Place this assembly on the floor of the cab. Make sure there is enough room to operate the valve control and the gear shift lever and to adjust the seat. Check below the floor for obstructions and cable routing. Relocate the valve control if necessary. Mark the floor using the pedestal as a template and drill 1/4” holes for the mounting screws and a 3/4” hole for the control cable. Assemble the control cable to the valve control head and assemble the valve

control head and cover to the pedestal using 5/16 x 2 1/4” machine screws, lock washers and hex nuts. Insert the control cable through the hole in the floor and mount the pedestal to the floor using 5/16 x 3/4” self-tapping screws. Make sure the valve control lever is in its center detent position. Keep the control cable away from hot exhaust pipes and rotating drive shafts. The control cable should not have any sharp bends or kinks in it (these will make the control harder to operate).

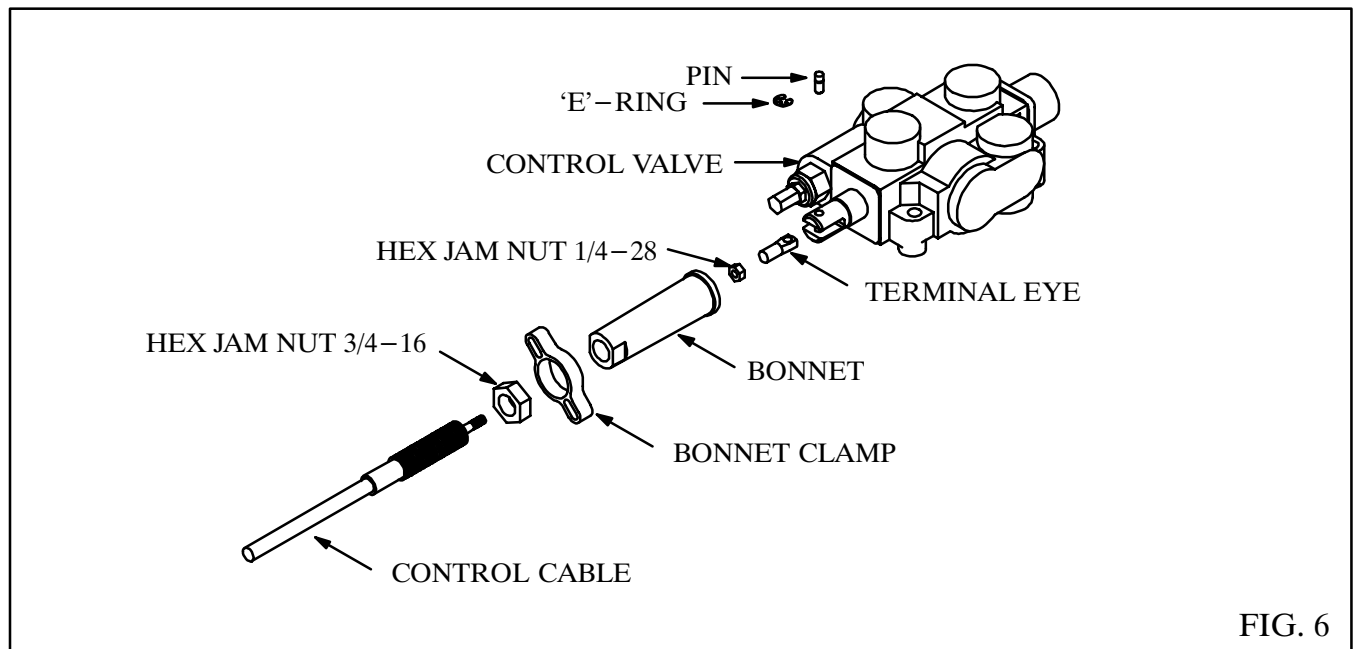

Install the 3/4” hex jam nut onto the valve end of the control cable and turn past the threads. Insert the end of the cable through the bonnet clamp. Install the bonnet onto the control cable and turn it past the threads also. Install the 1/4” hex jam nut and terminal eye on the core rod of the cable. Lock the terminal eye to the core rod using the hex jam nut. Place the terminal eye in the slot of the valve spool; insert the short pin through the valve spool and terminal eye and secure it in place with the 'E' ring.

Thread the bonnet onto the end of the cable so it firmly touches the end valve. (Do not over or under tighten the bonnet as either would move the valve spool out of its neutral position.) Remove two cap screws from opposite corners of the seal retainer plate. Slide the bonnet clamp onto the bonnet and secure it to the valve using the 1/4 x 1 1/4” cap screws, lock washers and flat washers. Lock the bonnet to the cable using the 3/4” hex jam nut. See Fig. 6.

INSTALL HOSES – 1500 & 1900

Study Fig. 8 very carefully before connecting the hoses. Install a 1 1/4" 90° street elbow and a 1 1/4" hose barb in the suction port on the bottom of the reservoir. Install a 1 5/16 ORB x 1 1/4" hose barb in the suction port on the pump and install the suction hose. Secure the suction hose in place using hose clamps. Install a 1 5/16 ORB x 1/2 NPT adapter in the pressure port of the pump and install a 90° swivel adapter in the 'IN' port on the control valve. Install the 72" long 1/2" hose from the pump to the valve.

Install 90° swivel adapters in the work port of the control valve and the ports on the base end of the cylinders. Connect a 60" long 1/2" hose from the control valve to the swivel nut tee; connect a 24" long 1/2" hose from the tee to the ports on the base end of the cylinder. This will raise the hoist when the control lever is pulled back and lower it when pushed forward. Secure the 24" long hoses to the cylinder mount using the tie straps provided.

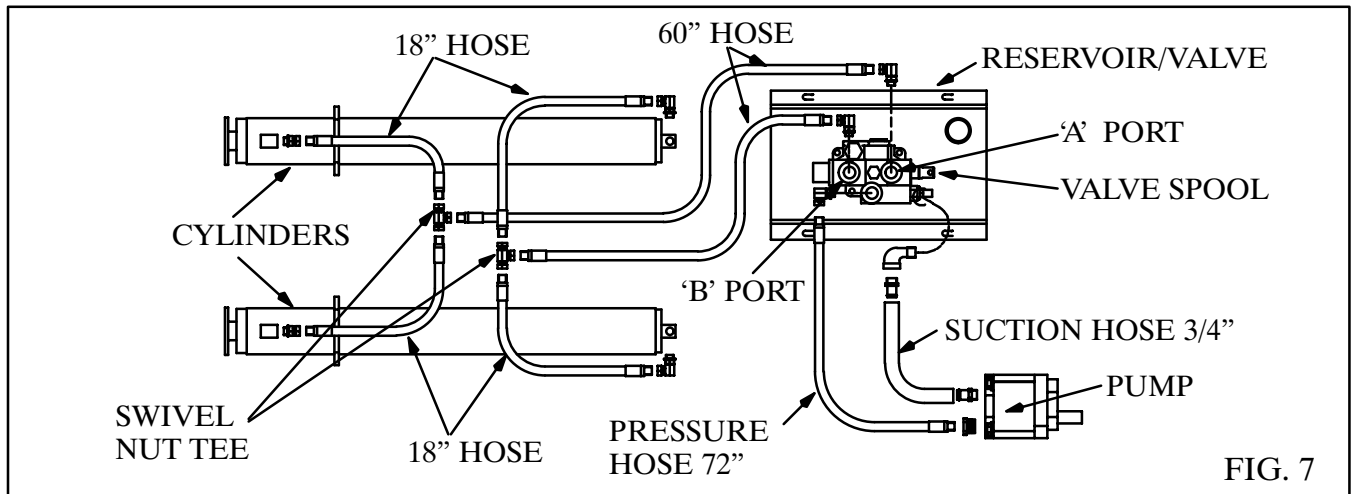

INSTALL HOSES – 3300 & 4400 SINGLE-ACTING

Study Fig. 8 very carefully before connecting the hoses. Install a 1 1/4" 90° street elbow and a 1 1/4" hose barb in the suction port on the bottom of the reservoir. Install a 1 5/16 ORB x 1 1/4" hose barb in the suction port on the pump and install the suction hose. Secure the suction hose in place using hose clamps. Install a 1 5/16 ORB x 1/2 NPT adapter in the pressure port of the pump and install a 90° swivel adapter in the 'IN' port on the control valve. Install the 72" long 1/2" hose from the pump to the valve.

Install 90° swivel adapters in the work port of the control valve and the ports on the base end of the cylinders. Connect a 60" long 1/2" hose from the control valve to the swivel nut tee; connect a 24" long 1/2" hose from the tee to the ports on the base end of the cylinder. This will raise the hoist when the control lever is pulled back and lower it when pushed forward. Secure the 24" long hoses to the cylinder mount using the tie straps provided.

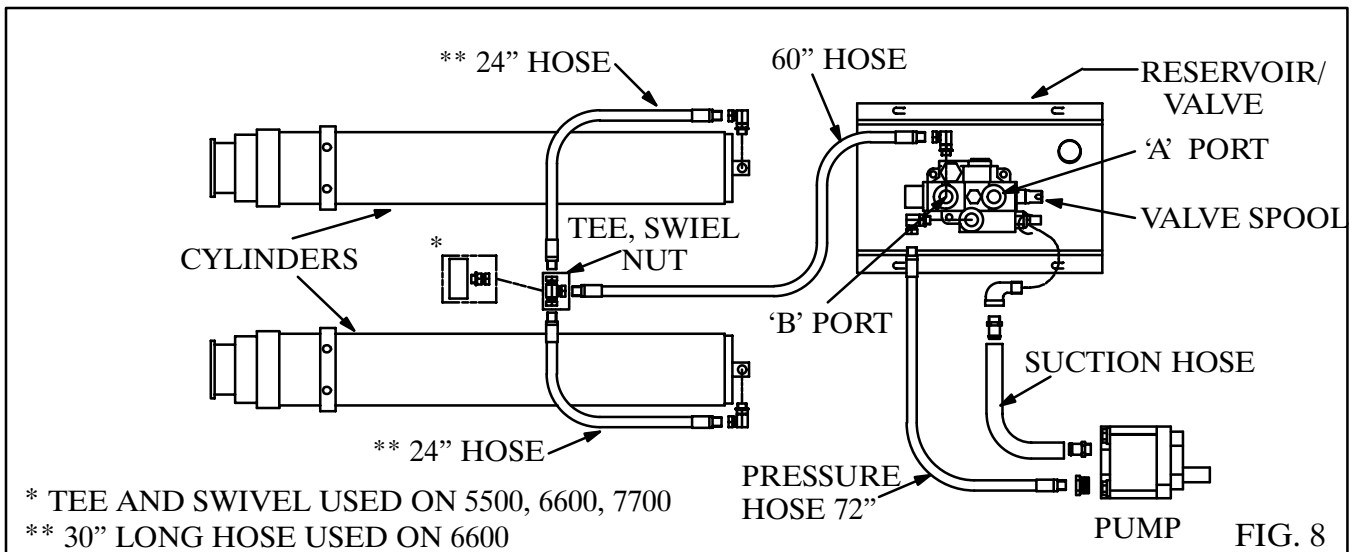

INSTALL HOSES – 5500, 6600 & 7700 SINGLE-ACTING

Study Fig. 8 very carefully before connecting the hoses. Install a 1 1/2" 90° street elbow and an 1 1/2" hose barb in the suction port on the bottom of the reservoir. Install a 1 5/16 ORB x 1 1/2" hose barb in the suction port of the pump and install the suction hose. Secure the suction hose in place using hose clamps. Install a 1 5/16 ORB x 3/4" NPT adapter in the pressure port of the pump and install a 90° swivel adapter in the "IN" port of the control valve. Install the 72" long 3/4" hose from the pump to the valve.

Install 90° swivel adapters in the work port of

the control valve and the ports on the base end of the cylinders. Install a 7/8 ORB x 3/4" NPT swivel in the middle port of the 7/8 ORB tee.

Connect a 60" long 3/4" hose from the control valve to the middle port of the tee; connect 24" long 1/2" NPT-7/8 ORB hoses (30" long hoses for the 6600) from the tee to the ports on the base end of the cylinders. This will raise the hoist when the control lever is pulled back and lower it when pushed forward. Secure the 24" (30") long hoses to the cylinder mount using the tie straps provided.

INSTALL HOSES – 3300 & 4400 DOUBLE-ACTING

Study Fig. 9 very carefully before connecting the hoses. Install a 1 1/4" 90° street elbow and a 1 1/4" hose barb in the suction port on the bottom of the reservoir. Install a 1 5/16 ORB x 1 1/4" hose barb in the suction port on the pump and install the suction hose. Install a 1 5/16 ORB x 1/2" NPT adapter in the pressure port of the pump and install a 90° swivel adapter in the 'IN' port of the control valve. Install the 72" long 1/2" hose from the pump to the valve. Secure the suction hose in place using hose clamps.

Install 90° swivel adapters in the work ports of the control valve and the ports on the base end of the cylinders. Connect a 60" long 1/2" hose from

the control valve to the swivel nut tee; connect 24" long 1/2" hose from the tee to the ports on the base end of the cylinder. Secure the 24" long hoses to the cylinder mount using the tie straps provided.

There is plumbing inside the hoist frame for the power down function of the hoist. Install a 3/8" NPT x 1/2" NPT swivel adapter in the pipe elbow near the front of the hoist frame. Connect a 42" long 1/2" hose from the 'A' port on the control valve to the swivel adapter. Connect 27" long 1/4" hoses from the pipe fittings on the upper frame to the ports on the rod end of the cylinders. This will raise the hoist when the control le-

ver is pulled back and lower it when pushed forward.

NOTE: The 'A' port is the 'power-down' port

and has a pressure of only 500–1000 PSI; the 'B' port has full system pressure.

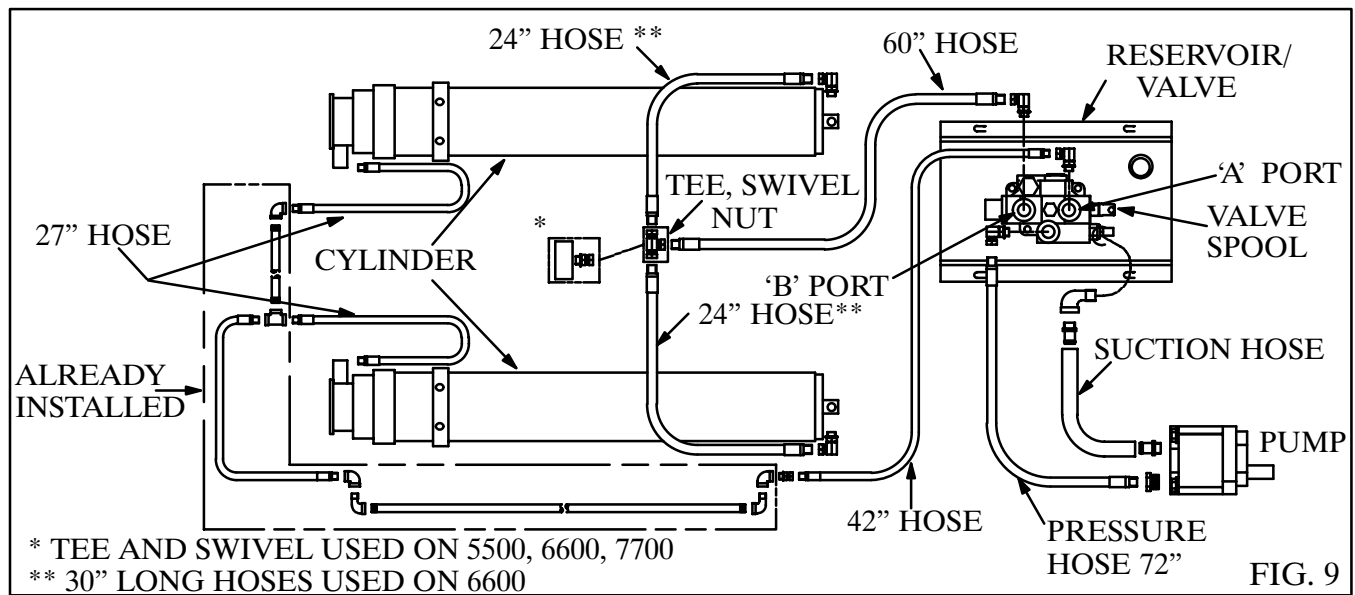

INSTALL HOSES – 5500, 6600 & 7700 DOUBLE-ACTING

Study Fig. 9 very carefully before connecting the hoses. Install a 1 1/2" 90° street elbow and an 1 1/2" hose barb in the suction port on the bottom of the reservoir. Install a 1 5/16 ORB x 1 1/2" hose barb in the suction port of the pump and install the suction hose. Secure the suction hose in place using hose clamps. Install a 1 5/16 ORB x 3/4 NPT adapter in the pressure port of the pump and install a 90° swivel adapter in the 'IN' port of the control valve. Install the 72" long 3/4" hose from the pump to the valve.

Install 90° swivel adapters in the work ports of the control valve and the ports on the base end of the cylinders. Install a 7/8 ORB x 3/4 NPT swivel in the middle port of the 7/8 ORB tee. Connect a 60" long 3/4" hose from the control valve to the middle port of the tee; connect 24" long 1/2" hoses (30" long hoses for the 6600) from the tee

to the ports on the base end of the cylinders. Secure the 24" (30") long hoses to the cylinder mount using the tie straps provided.

There is plumbing inside the hoist frame for the power down function of the hoist. Install a 3/8 NPT x 1/2 NPT swivel adapter in the pipe elbow near the front of the hoist frame. Connect a 42" long 1/2" hose from the 'A' port on the control valve to the swivel adapter. Connect 27" long 1/4" hoses from the pipe fittings on the upper frame to the ports on the rod end of the cylinders. This will raise the hoist when the control lever is pulled back and lower it when pushed forward.

NOTE: The 'A' port is the 'power-down' port and has a pressure of only 500–1000 PSI; the 'B' port has full system pressure.

ADD HYDRAULIC OIL

Refer to TABLE 2 below for the amount of hydraulic oil required to operate the hoist. Use a quality hydraulic fluid of 150 SSU @ 100°F. which contains corrosion and oxidation inhibitors and a foam depressant. This is approxi-

mately the equivalent of SAE 10W or lighter weight oil, or use Type A automatic transmission fluid for improved performance in cold weather.

TABLE 2

HOIST MODEL	RESERVOIR SIZE	OIL REQUIRED	HOIST MODEL	RESERVOIR SIZE	OIL REQUIRED
1500	6 GAL.	13QTS	5500	14 GAL.	34QTS
1900	6 GAL.	15QTS	6600	14 GAL.	39QTS
3300	8 GAL.	20QTS	7700	14 GAL.	42QTS
4400	8 GAL.	27QTS			

MOUNT BODY

It is recommended that the body be painted before it is mounted on the truck. Place the body in position on the truck with three inches of clearance behind the cab. Use the rivet strip mounting pads between the longbeams and the truck frame. Use three on each side, spaced as seen on Fig. 2 on page 5 or Fig. 3 on page 6. Weld them to the longbeams. Align body longbeams carefully with the truck frame. Securely weld the longbeams to the rear hinge brackets.

the hoist. On the inside of the longbeams, insert the filler plate between the lift bracket and the longbeam. Securely weld the filler plate to the angle lift brackets and to both flanges of the longbeam channels as shown in Fig. 10. For Crysteel's new grain body, place the filler plate between the angle lift bracket and the inside of the longbeam as shown in Fig. 11. Securely weld this plate to the longbeam and to the lift bracket. Be sure to do this on both sides.

Weld the longbeams to the angle lift brackets of

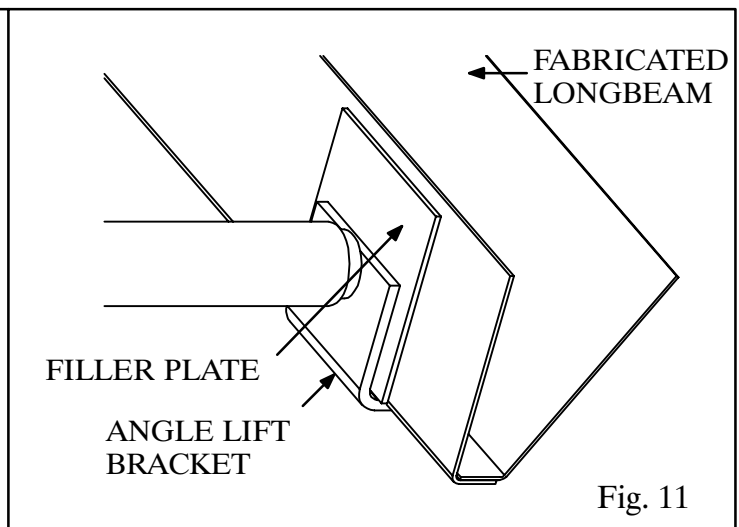
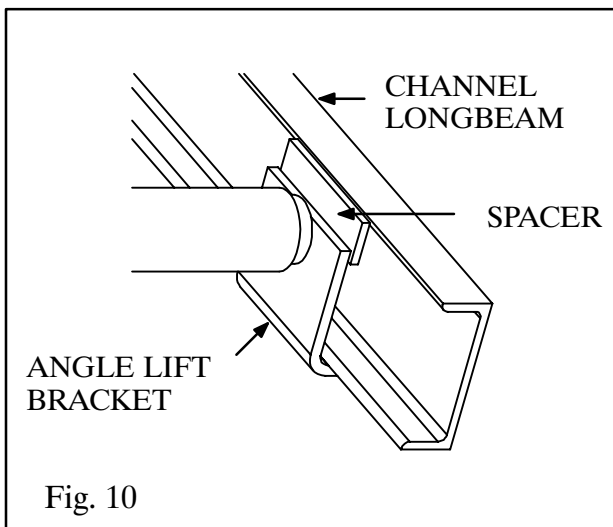

INSTALL BODY GUIDES

The four body guides supplied with your hoist are of two types. Part number 217503 has an obtuse angle that allows it to match the angle of fabricated longbeams. Position this type as shown in Fig. 12 with wide end down, pushed against the longbeam, and centered over the hoist lower mounting angle. Weld securely to the mounting angles. **DO NOT** use the other body guides with fabricated longbeams.

Part number 201415 body guide is used with

channel type longbeams and has a right angle that allows it to be positioned as shown in Fig. 13. Position this guide 1/4" away from the longbeam, centered over the lower mounting angle. Place the 217503 body guide inside of it as shown so that the flat sides of the guides fit together. Weld number 201415 to the lower mounting angle and 217503 to the longbeam.

There should be **NO SIDEPLAY** when the truck body is in the lowered position.

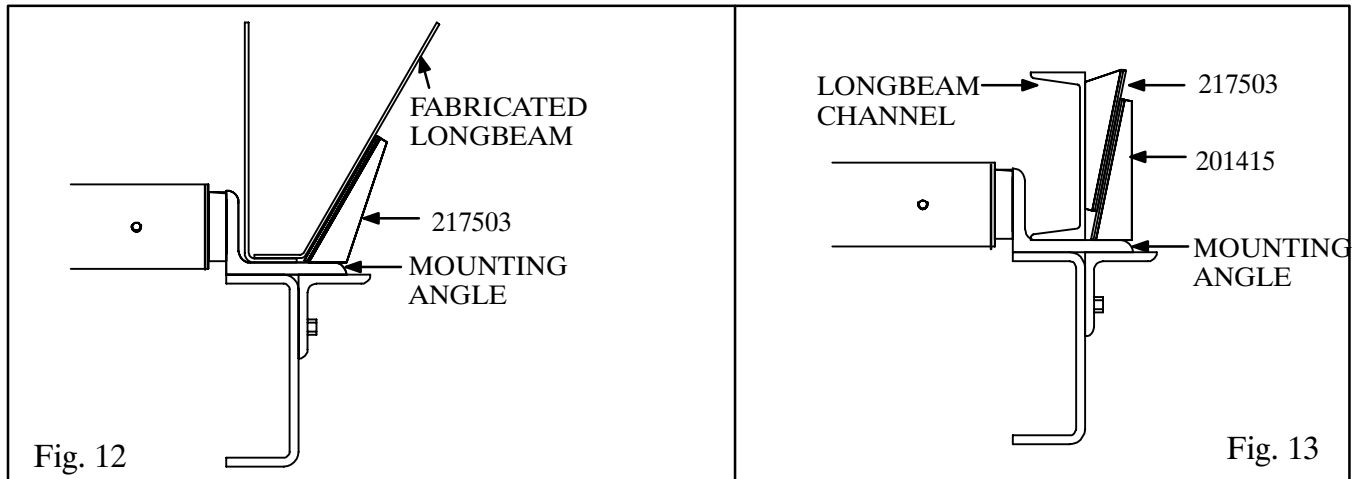

INSTALL BODY PROP

The body prop is designed and intended to support an **EMPTY** truck body in the raised position. Use of the body prop permits service to be performed safely beneath a raised body. One body prop is included with Stingray Hoist models 1500 and 1900; two body props (one pair) are included with models 3300 through 7700. Be sure to install each prop on the correct side of the truck as explained below. (See Fig. 14)

1. Raise the body to a 30° to 35° angle and brace it securely before beginning installation.
2. Assemble the prop arm to the prop pivot mount with a 1/4 x 3 roll pin. Clamp the prop pivot mount against the outside of the truck frame just behind the rear axle. Raise the body prop arm to a free standing position. Place the body prop bracket in the prop arm saddle. Reposition if needed to locate the
3. prop bracket on the longbeam. It may be necessary to raise or lower the body to get the best location for the prop pivot mount. Using the prop pivot mount as a guide, mark the location of holes on the truck frame and drill 17/32 inch holes. Assemble the prop pivot mount to the frame using 1/2 x 1 3/4 cap screws, lock washers and hex nuts. Raise the prop arm to a free standing position, place the body prop bracket in the saddle and securely weld the bracket to the longbeam.
4. When mounting two body props, repeat steps 1 and 2 for the other side. Use the body prop already mounted to assure that both body props hold the body at the same height. The left and right body props should pivot toward the front of the truck in the storage position.
5. To operate the body prop, raise the body to the desired height, shut off all power, raise the prop arm to a free standing position.

Lower the body slowly until the body prop bracket contacts the prop arm saddle. **DO NOT POWER HOIST DOWN.**

5. To place the body prop in the storage posi-

tion, raise the body to clear the body prop saddle, lower the body prop to the storage position and lower the body.

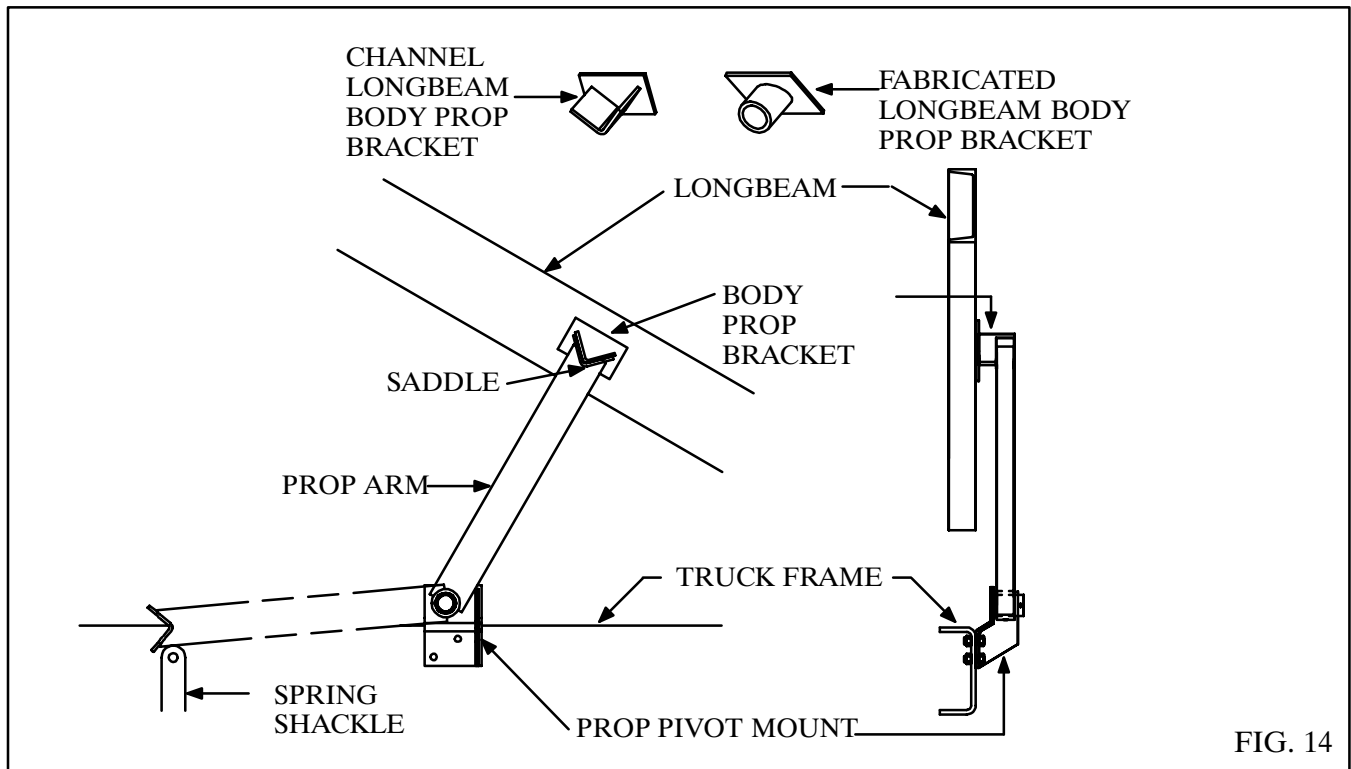

GREASE HOIST

Install grease zerks and lubricate in the following locations:

- A. Upper Crosstube 2 fittings
- B. Lower Crosstube 2 fittings
- C. Body Props 2 fittings
- D. Rear Hinge . . . 2 fittings (Installed)

Lubricate all fittings at regular intervals, at least

every 200 cycles or 2 months. There are very high forces on the bearing surfaces within the hoist frame. It pays to be generous in lubricating the hoist to ensure proper operation and long life.

NOTE: The crossheads, the lower cylinder mount pivots and the center hinge of the hoist are equipped with SELF LUBRICATING COMPOSITE BEARINGS. These points do not need to be greased.

BLEED CYLINDERS – SINGLE ACTING

The StingRay single-acting cylinders are equipped with a self-bleeding feature. When first installed, raise the body to full height and lower completely two or three times. Air is removed from the cylinder every time the hoist is cycled. No further bleeding is required.

NOTE: Double-acting cylinders do not have bleed valves because they bleed themselves in use. Cycle the hoist several times to remove any air from the cylinders

INSTALL DECALS

There should be a total of 8 decals supplied in the manual packet. Be sure that you have all of them as shown on the following page. If you do not, notify Crysteel and we will gladly supply those missing. Be careful that the decals are

placed in the proper places and are applied to a clean, dry surface. Locations are described on the next page. Installation is not considered complete without all decals in place.

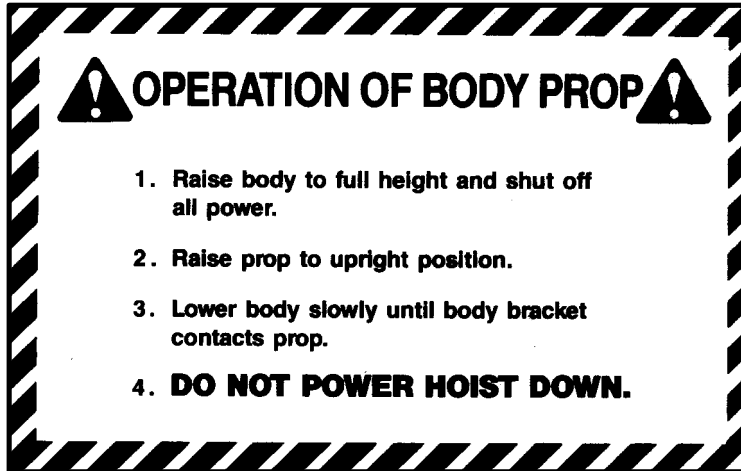

400719—Mount on the body longbeam near the body prop

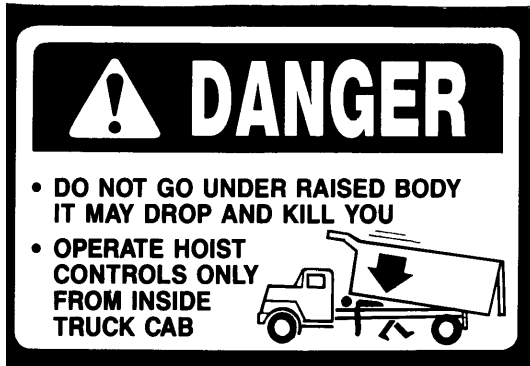

401576—Mount on the outside of the body longbeams near the front of the body (one on each side).



400643—Mount on the longbeam on the drivers side.

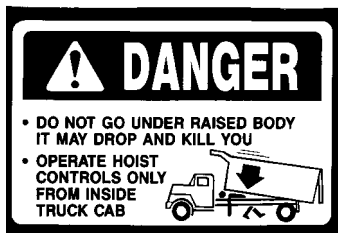

401577—Mount in the cab in a prominent location

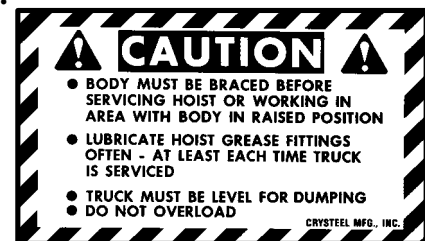

400642—Mount in the cab in a prominent location?



400661 — Mount on the body prop arm.

FIG. 15

ROUTINE MAINTENANCE

LUBRICATE REGULARLY

Install grease zerks and lubricate the Stingray Hoist in the following locations:

- A. Body Prop 2 fittings
- B. Upper Crosstube 2 fittings
- C. Lower Crosstube 2 Fittings
- D. Rear Hinge 2 Fittings

Lubricate all fittings at regular intervals, at least every 200 cycles or 2 months. There are very high

forces on the bearing surfaces within the hoist frame. It pays to be generous in lubricating the hoist to ensure proper operation and long life.

NOTE: The crossheads, the lower cylinder mount pivots and the center hinge of the hoist are equipped with SELF LUBRICATING COMPOSITE BEARINGS. These points do not need to be greased.

CHANGE HYDRAULIC OIL

With normal use and working conditions the hydraulic oil should be changed annually. The breather cap should be cleaned regularly. With heavy use or very dusty working conditions the hydraulic oil should be changed more often.

KEEP THE OIL CLEAN! USE CLEAN CONTAINERS, FUNNELS AND OTHER EQUIPMENT!

Use a quality hydraulic fluid of 150 SSU @ 100° F. which contains corrosion and oxidation inhibitors and a foam depressant. This is approximately the equivalent of SAE 10W or lighter weight oil, or use Type A automatic transmission oil for improved performance in cold weather. Refer to chart on page 10 for the amount of oil needed.

STINGRAY 1500–1900 HOIST PARTS

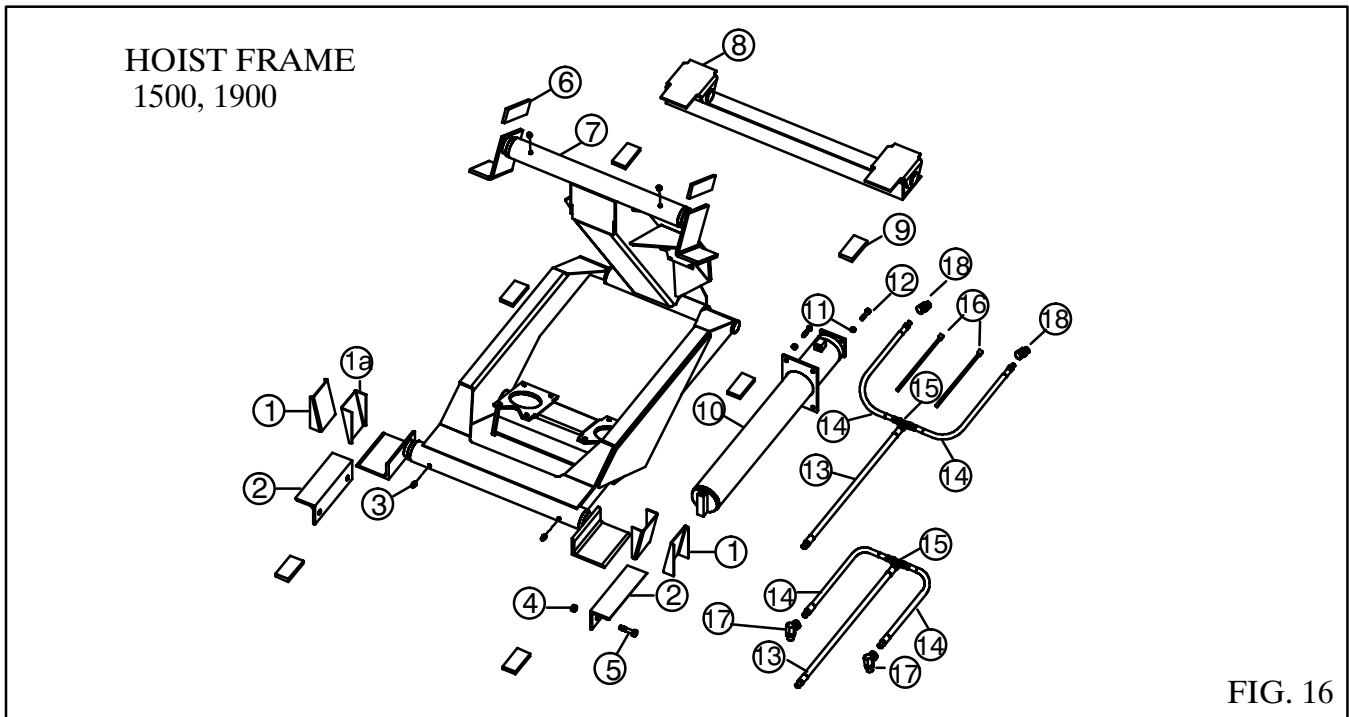

ITEM	DESCRIPTION	MODEL 1500	MODEL 1900	QTY.
1.	Body Guide	201415	201415	2
1a.	Body Guide	217503	217503	2
2.	Mounting Angle	201422	201422	2
3.	Grease Zerk	400103	400103	6
4.	Hex Lock Nut 5/8 NC	401582	401582	4
5.	Hex Cap Screw 5/8 NC x 2	402374	402374	4
6.	Longbeam Filler	200900	200900	2
7.	Hoist Frame	112972	112972	1
8.	Rear Hinge	106060	106060	1
9.	Longbeam Spacer	200892	200892	6
10.	Cylinder	112138	111717	2
11.	Hex Lock Nut 3/8 NC	401316	401316	8
12.	Hex Cap Screw 3/8 NC x 1 1/2	400114	400114	8
13.	Hose 3/8 NPT X 60	402471	402471	2
14.	Hose 3/8 NPT X 18	402470	402470	2
15.	Swivel Tee 3/8 NPSM	402156	402156	2
16.	Tie Strap	401542	401542	2
17.	Adapter 9/16 ORBM X 3/8 NPSM 90°	402162	402162	2
18.	Swivel 9/16 ORBM X 3/8 NPSM	402161	402161	2

STINGRAY 1500–1900 CYLINDER PARTS

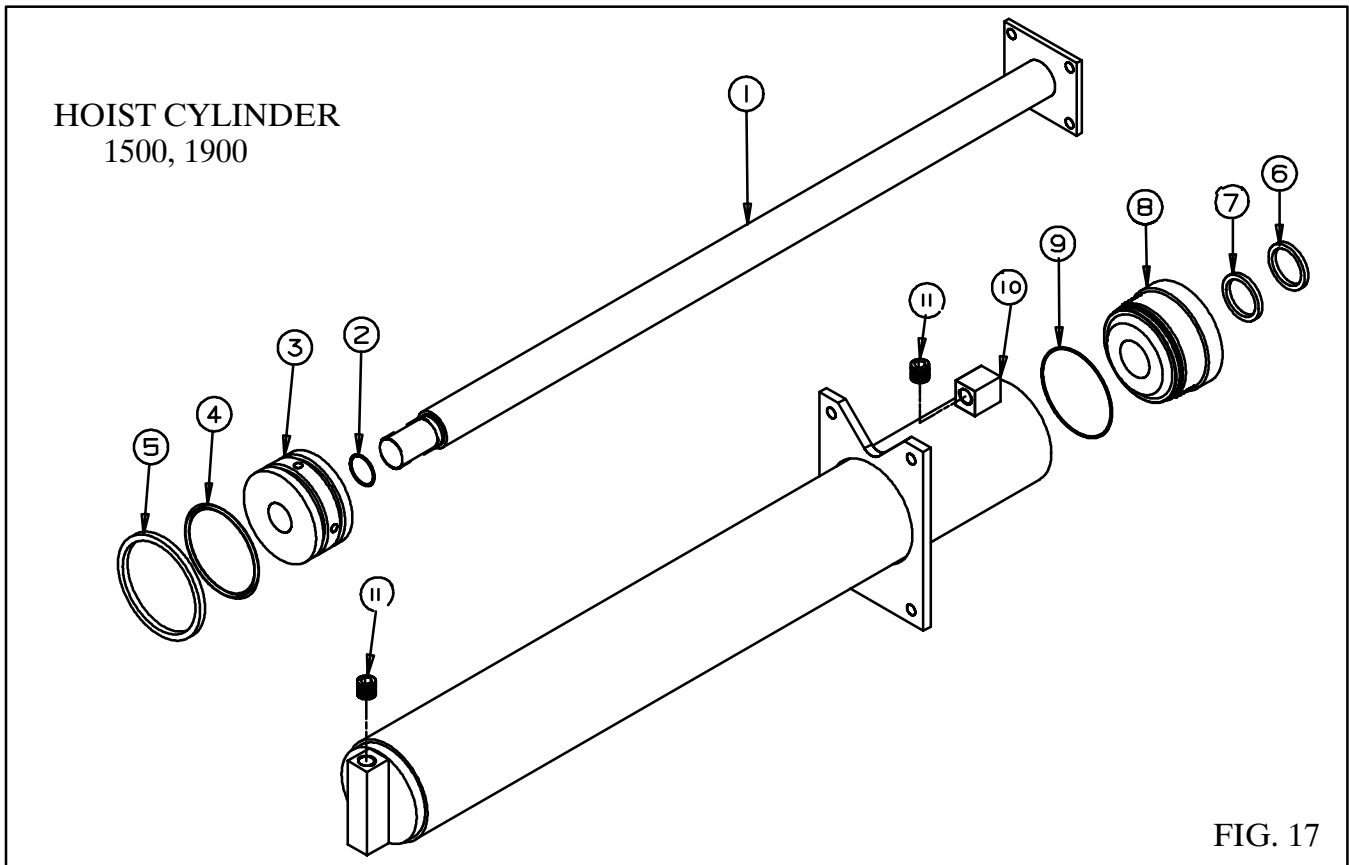

ITEM	DESCRIPTION	MODEL 1500	MODEL 1900	QTY.
1.	Shaft Assy	112141	112141	1
2.	O–Ring *	401131	401131	1
3.	Piston	215364	214838	1
4.	O–Ring *	401633	401616	1
5.	Poly Seal *	401645	401646	1
6.	Wiper	401617	401617	1
7.	Poly Seal *	401132	401132	1
8.	Head	215363	214837	1
9.	O–Ring *	401634	400957	1
10.	Outer Tube Assy	112140	111721	1
11.	Plug 9/16 ORB	400404	400404	2
12.	Seal Kit (includes items with *)	113478	113479	1

401509

19

03112005

SINGLE
ACTING

3300 7700

DOUBLE
ACTING

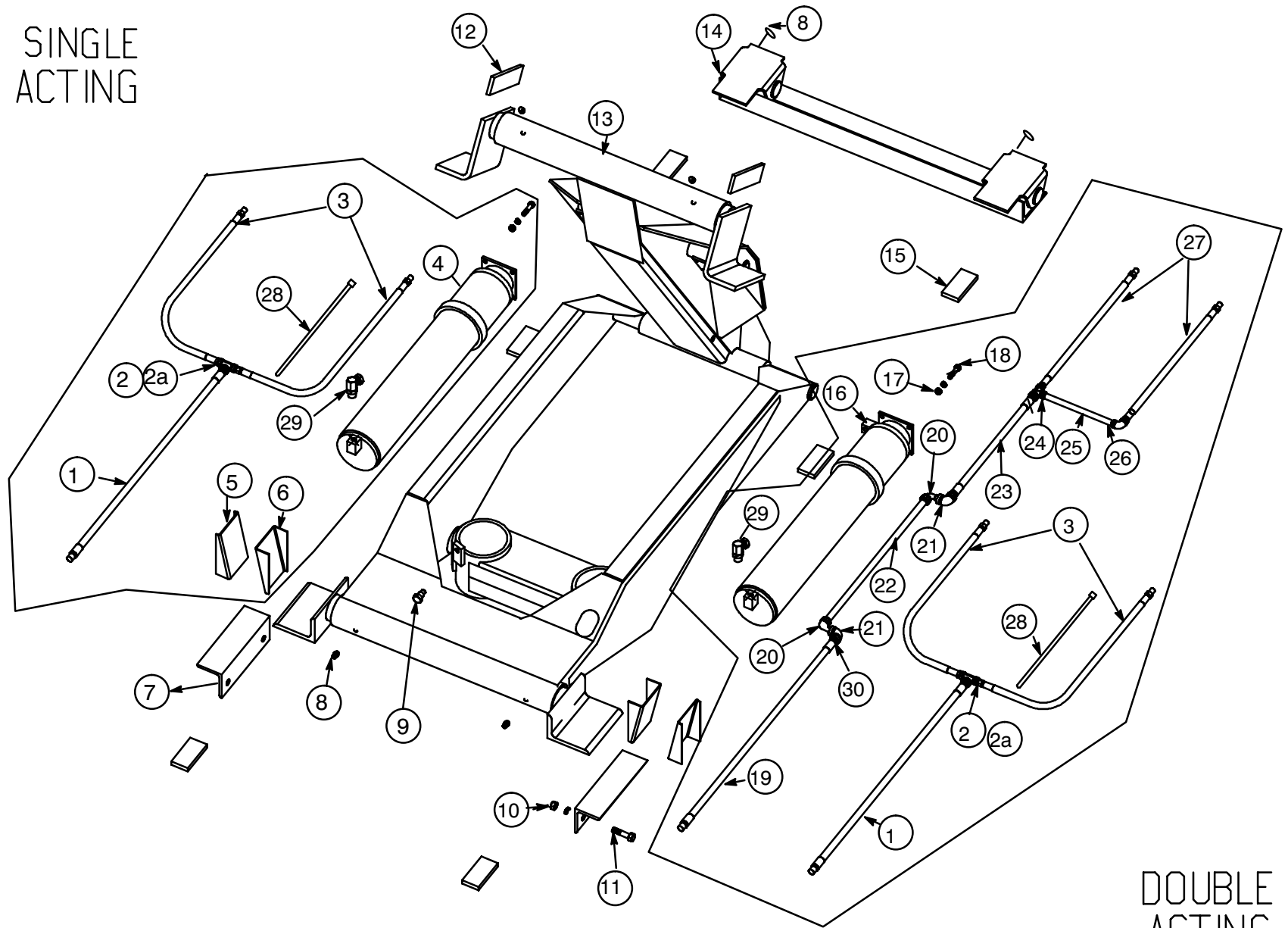

STINGRAY 3300-7700 HOIST PARTS

ITEM	DESCRIPTION	MODEL 3300	MODEL 4400	MODEL 5500	MODEL 6600	MODEL 7700	QTY
1.	Hose 1/2 NPT	401502	402143	401938	401938	401938	1
2.	Tee 1/2 NPSM Swivel	402165	402165				1
	Tee 7/8 ORB			200033	200033	200033	1
2a.	Swivel 7/8 ORBM x 3/4 NPTF			402079	402079	402079	1
3.	Hose 1/2 NPT	402166	402166	401303	402159	401303	2
4.	Cylinder – SA	128453	128454	128455	128456	128457	2
5.	Body Guide	201415	201415	201415	201415	201415	2
6.	Body Guide	217503	217503	217503	217503	217503	2
7.	Mounting Angle	201422	201422	201422	201422	201422	2
8.	Grease Zerk 1/8 NPT	400103	400103	400103	400103	400103	6
9.	Retaining Screw	401612	401612	401612	401612	401612	2
10.	Hex Lock Nut 5/8 NC	401582	401582	401582	401582	401582	4
11.	Hx Cap Screw 5/8 x 2	402374	402374	402374	402374	402374	4
12.	Longbeam Filler	200896	200896	200896	200896	200896	2
13.	Hoist Frame – SA	110021	110026	109655	110293	110373	1
	Hoist Frame – DA	111348	111349	111350	111352	111354	1
14.	Rear Hinge	107037	107037	107037	107037	107037	1
15.	Longbeam Spacer	200890	200890	200890	200890	200890	6
16.	Cylinder – DA	111072	111073	111074	111076	111078	2
17.	Hex Lock Nut 3/8 NC	401316	401316	401316	401316	401316	8
18.	Hx Cap Screw 3/8 x 1 1/2	400114	400114	400114	400114	400114	8
19.	Hose 1/2 NPT x 42	402141	402141	402141	402141	402141	1
20.	Street Elbow 3/8	400412	400412	400412	400412	400412	2
21.	Elbow 3/8	400413	400413	400413	400413	400413	2
22.	Pipe 3/8	401521	401521	401597	401598	401599	1
23.	Hose 3/8 NPT	400510	400510	400512	400513	400514	1
24.	Tee Reducing 3/8 x 1/4 x 1/4	401519	401519	401519	401519	401519	1
25.	Pipe 1/4 x 9	401520	401520	401520	401520	401520	1
26.	Ellbow 1/4	400417	400417	400417	400417	400417	1
27.	Hose 1/4 NPT x 27	402301	402301	402301	402301	402301	2
28.	Tie Strap	401542	401542	401542	401542	401542	3
29.	Adapter 7/8 ORBM x 1/2 NPTF 90°	401107	401107	401107	401107	401107	2
30.	Swivel 3/8 NPTM x 1/2 NPTF	402152	402152	402152	402152	402152	1

STINGRAY 3300 – 7700SA CYLINDER PARTS

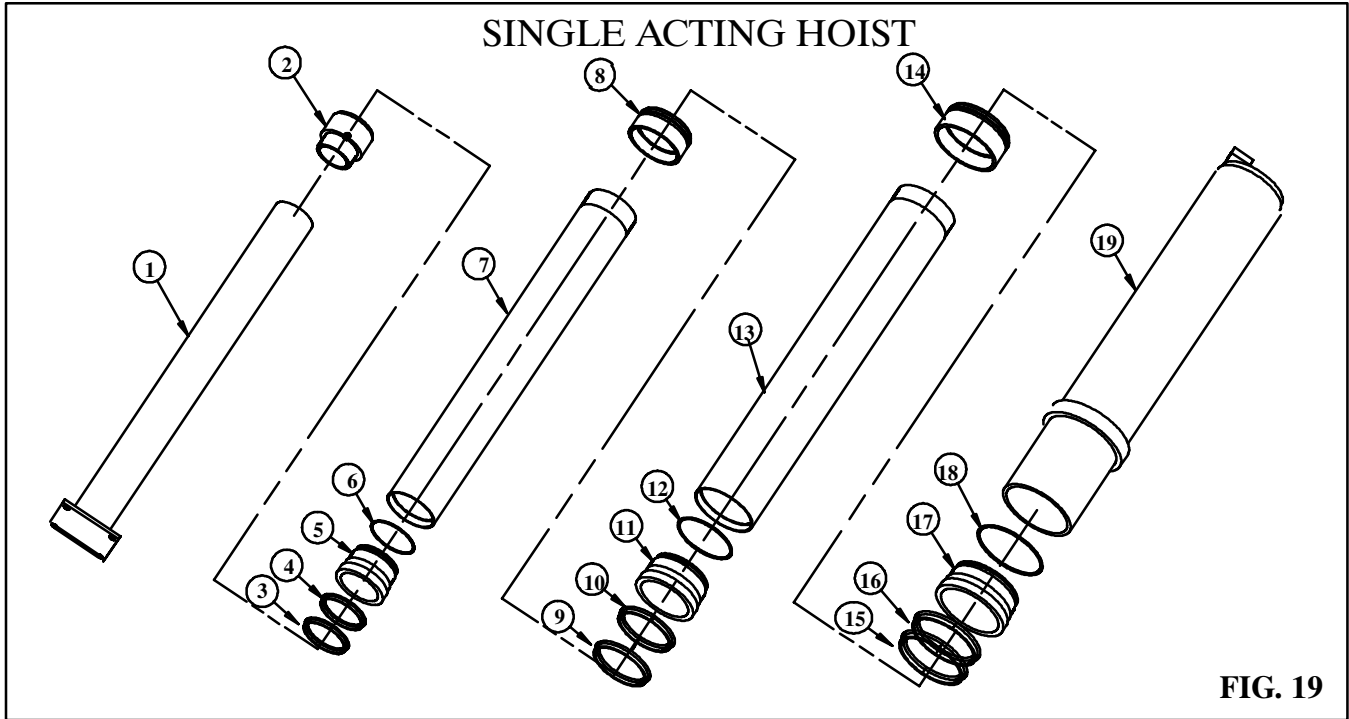

FIG. 19

ITEM	DESCRIPTION	MODEL 3300	MODEL 4400	MODEL 5500	MODEL 6600	MODEL 7700	QTY
1.	Inner Tube Assy	135257	133942	135258	135259	135260	1
2.	Inner Piston	213683	213684	213683	213683	213683	1
3.	Wiper 2 3/4 ID	402536	--	402536	402536	402536	1
4.	Seal 2 3/4 IC x 1/4 *	401695	--	401695	401695	401695	1
5.	Head 2 3/4 ID	253750	--	253750	253750	253750	1
6.	O-Ring 2 7/8 ID x .070 *	400956	--	400956	400956	400956	1
7.	Stage Tube 3 1/2 OD	251561	--	251562	251563	251564	1
8.	Piston 3 1/2 Stage	208360	--	208360	208360	208360	1
9.	Wiper 3 1/2 ID *	402498	402498	402498	402498	402498	1
10.	Seal 3 1/2 ID x 1/4 *	401596	401596	401596	401596	401596	1
11.	Head 3 1/2 ID	251597	251597	251597	251597	251597	1
12.	O-Ring 3 1/2 ODx.070 *	400957	400957	400957	400957	400957	1
13.	Stage Tube 4 1/4 OD	--	253763	253764	253765	253766	1
14.	Piston 4 1/4 Stage	--	208361	208361	208361	208361	1
15.	Wiper 4 1/4 ID *	--	402499	402499	402499	402499	1
16.	Seal 4 1/4 ID x 1/4 *	--	401697	401697	401697	401697	1
17.	Head 4 1/4 ID	--	253751	253751	253751	253751	1
18.	O-Ring 4 1/4 ODx.070 *	--	400958	400958	400958	400958	1
19.	Outer Tube Assy	138014	138015	133935	138016	138017	1
20.	Seal Kit (includes *)	114346	114347	114348	114348	114348	

STINGRAY 3300–7700DA CYLINDER PARTS

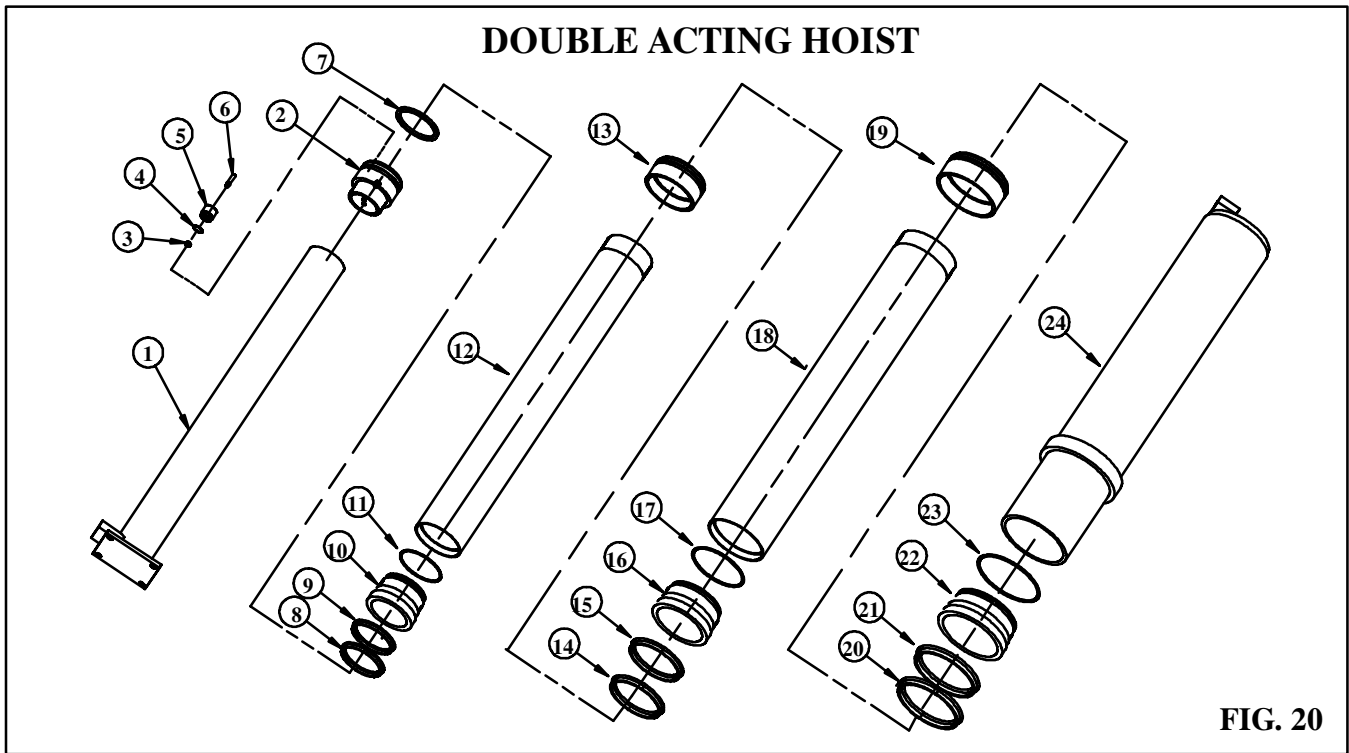

FIG. 20

ITEM	DESCRIPTION	MODEL 3300	MODEL 4400	MODEL 5500	MODEL 6600	MODEL 7700	QTY
1.	Inner Tube Assy	135253	133941	135254	135255	135256	1
2.	Inner Piston	218237	218238	218237	218237	218237	1
3.	Bal; 3/8 Dia	400013	400013	400013	400013	400013	1
4.	O–Ring 7/16 ID	401017	401017	401017	401017	401017	1
5.	Bypass Valve Body	400978	400978	400978	400978	400978	1
6.	Bypass Valve Pin	401338	401338	401338	401338	401338	1
7.	Seal, PIP 3” OD *	401777	--	401777	401777	401777	1
	Seal, PIP 3 3/4 OD *	--	401778	--	--	--	1
8.	Wiper 2 3/4 ID	402536	--	402536	402536	402536	1
9.	Seal 2 3/4 IC x 1/4 *	401695	--	401695	401695	401695	1
10.	Head 2 3/4 ID	253750	--	253750	253750	253750	1
11.	O–Ring 2 7/8 ID x .070 *	400956	--	400956	400956	400956	1
12.	Stage Tube 3 1/2 OD	218231	--	218232	218233	218234	1
13.	Piston 3 1/2 Stage	208360	--	208360	208360	208360	1
14.	Wiper 3 1/2 ID *	402498	402498	402498	402498	402498	1
15.	Seal 3 1/2 ID x 1/4 *	401696	401696	401696	401696	401696	1
16.	Head 3 1/2 ID	251597	251597	251597	251597	251597	1
17.	O–Ring 3 1/2 ODx.070 *	400957	400957	400957	400957	400957	1
18.	Stage Tube 4 1/4 OD	--	253781	253764	253765	253766	1
19.	Piston 4 1/4 Stage	--	208361	208361	208361	208361	1

20.	Wiper 4 1/4 ID *	--	402499	402499	402499	402499	1
21.	Seal 4 1/4 ID x 1/4 *	--	401697	401697	401697	401697	1
22.	Head 4 1/4 ID	--	253751	253751	253751	253751	1
23.	O-Ring 4 1/4 ODx.070 *	--	400958	400958	400958	400958	1
24.	Outer Tube Assy	113797	113798	113799	113800	113801	1
25.	Seal Kit (includes *)	114350	114351	114352	114352	114352	

STINGRAY HYDRAULICS

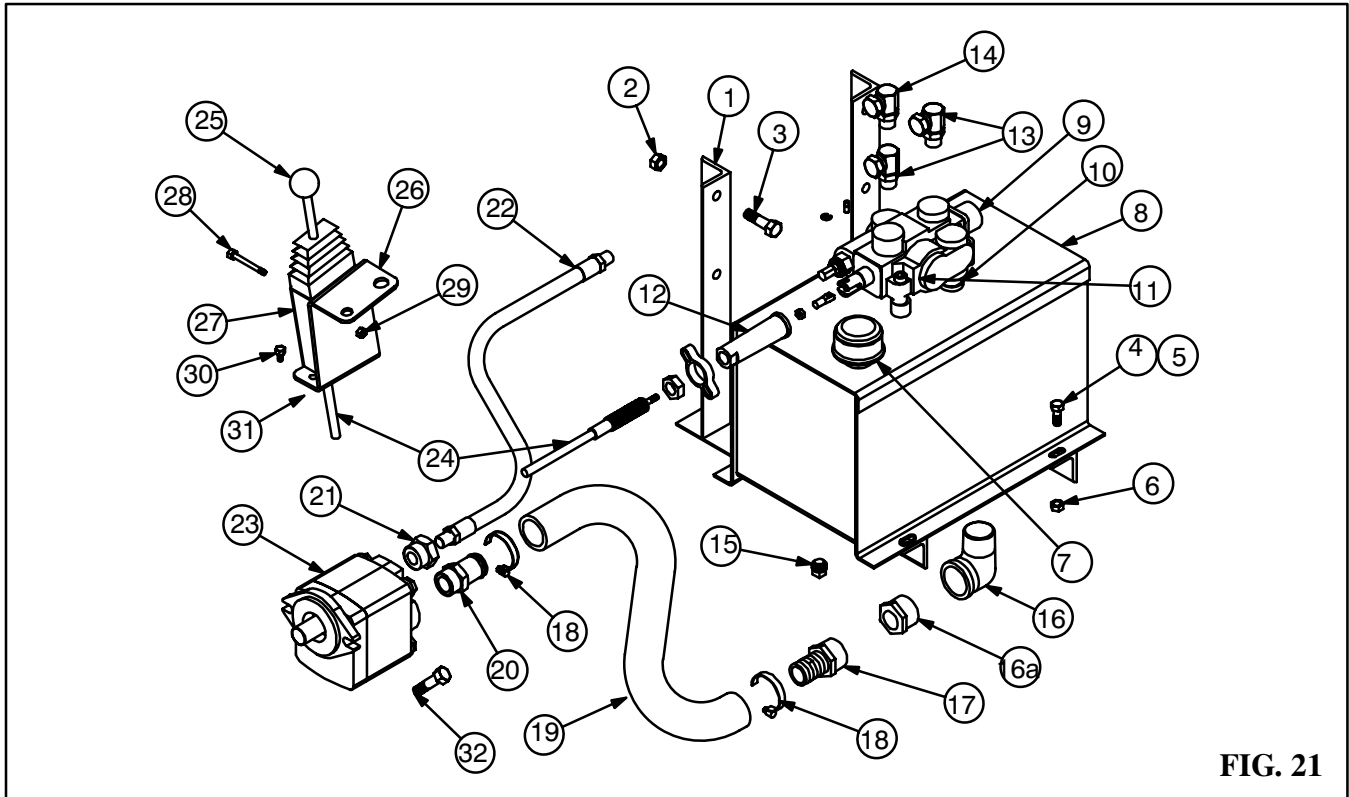

FIG. 21

ITEM	DESCRIPTION	MODELS	MODEL	MODEL	MODELS	QTY
		1500 1900	3300	4400	5500 6600 7700	
1.	Mounting Angle Assy	100511	100511	100511	100511	2
2.	Hex Lock Nut 1/2 NC	401316	401316	401316	401316	4
3.	Hex Cap Screw 1/2 NC x 2	400105	400105	400105	400105	4
4.	Hex Cap Screw 3/8 NC x 1	400121	400121	400121	400121	4
5.	Flat Washer 3/8	400164	400164	400164	400164	4
6.	Hex Lock Nut 3/8 NC	402038	402038	402038	402038	4
7.	Breather Cap	400764	400764	400764	400764	1
8.	Reservoir – 6 Gallon	116361	--	--	--	1
	Reservior – 8 Gallon	--	116350	116350	--	1
	Reservoir – 14 Gallon	--	--	--	116352	1

ITEM	DESCRIPTION	MODELS 1500 1900	MODEL 3300	MODEL 4400	MODELS 5500 6600 7700	QTY
9.	Valve – DA 4000 PSI 7/8 Ports	402068	402068	--	--	1
	Valve – SA 4000 PSI 7/8 Ports	--	402070	--	--	1
	Valve – DA 32500 PSI 7/8 Ports	--	--	402065	--	1
	Valve – SA 3250 PSI 1 1/16 Ports	--	--	402069	402069	1
	Valve – DA 3250 PSI 1 1/16 Ports	--	--	--	402104	1
10.	O–Ring .924 ID x .116 CS	401094	401094	401094	401094	1
11.	Soc Cap Screw 5/16 NC x 2	402115	402115	402115	402115	1
12.	Connection Kit – RVC	402127	402127	402127	402127	1
13.	Adapter 7/8 ORBM x 3/8 NPTF 90°	401200	--	--	--	DA 2
	Adapter 7/8 ORBM x 1/2 NPTF 90°	--	401107	--	--	DA 2 SA 1
	Adapter 7/8 ORBM x 1/2 NPTF 90°	--	--	401107	--	DA 2
	Adapter 1 1/16 ORBM x 1/2 NPTF 90°	--	--	-- 401285	401285	DA 1 SA 1
	Adapter 1 1/16 ORBM x 3/4 NPTF 90°	--	--	--	401291	DA 1 SA 1
14.	Adapter 1 1/16 ORBM x 1/2 NPTF 90°	401285	401285	401285	--	1
	Adapter 1 1/16 ORBM x 3/4 NPTF 90°	--	--	--	401291	1
15.	Pipe Plug 3/4 NPT Magnetic	400405	400405	400405	400405	1
16.	Pipe Elbow 3/4" Street 90°	402144	--	--	--	1
	Pipe Elbow 1 1/4 Street 90°	--	401296	401296	--	1
	Pipe Elbow 1 1/2 Street 90°	--	--	--	402145	1
16A.	Hex Bushing 1 1/2 NPT x 1 1/4 NPT	--	--	--	402149	1
17.	Hose Barb 3/4 NPT x 3/4	401447	--	--	--	1
17.	Hose Barb 1 1/4 NPT x 1 1/4	--	401449	401449	401449	1
18.	Hose Clamp #24	401441	--	--	--	2
	Hose Clamp 1 3/4 T–Bolt	--	402164	402164	402164	2
19.	Suction Hose 3/4 ID x 6'	404911	--	--	--	1
	Suction Hose 1 1/4 ID x 6'	--	404912	404912	404912	1
20.	Hose Barb 3/4 NPT x 3/4	401447	--	--	--	1
	Hose Barb 1 5/16 ORB x 1 1/4	--	401450	401450	401450	1

21.	Hex Bushing 3/4 NPT x 7/8 ORBF	404899	--	--	--	1
	Adapter 1 5/16 ORB x 7/8 ORB	--	210612	--	--	1
	Adapter 1 5/16 ORB x 1/2 NPTF	--	--	210608	--	1
	Adapter 1 5/16 ORB x 3/4 NPTF	--	--	--	219825	1
ITEM	DESCRIPTION	MODELS 1500 1900	MODEL 3300	MODEL 4400	MODELS 5500 6600 7700	QTY
22.	Hose 1/2 NPT x 72 4000 PSI	401446	401446	--	--	1
	Hose 1/2 NPT x 72 3500 PSI	--	--	401445	--	1
	Hose 3/4 NPT x 72 3000 PSI	--	--	--	401937	1
23.	Pump 6 GPM DM	400394	--	--	--	1
	Pump 10 GPM DM	--	402114	--	--	1
	Pump 10 GPM DM	--	--	402344	--	1
	Pump 15 GPM DM	--	--	--	402113	1
24.	Cable Valve Control 96"	402122	402122	402122	402122	1
25.	Remote Valve Control – Wescon	402120	402120	402120	402120	1
26.	Pedestal Tall Wescon	223396	223396	223396	223396	1
27.	Channel Pedestal Cover Tall	223397	223397	223397	223397	1
28.	Mach Screw 5/16 x 2 1/2	402154	402154	402154	402154	3
29.	Hex Lock Nut 5/16 NC	401240	401240	401240	401240	5
30.	Mach Screw 5/16 x 1/2	402415	402415	402415	402415	2
31.	Clamp Plate – Pedestal	225127	225127	225127	225127	1
32.	Hex Cap Screw 1/2 NC x 1 1/4	400153	400153	400153	400153	4

Standard Valve/Tank Assembly Numbers				
Hoist Model	Assy Number	Tank Size	Pressure Setting	Work Port Size
1500	116652	6 Gal	4000 PSI	7/8 ORB
1900	116652	6 Gal	4000 PSI	7/8 ORB
3300 DA	116655	8 Gal	4000 PSI	7/8 ORB
3300 SA	116656	8 Gal	4000 PSI	7/8 ORB
4400 DA	116653	8 Gal	3250 PSI	7/8 ORB
4400 SA	116654	8 Gal	3250 PSI	1 1/16 ORB
5500 DA	116657	14 Gal	3250 PSI	1 1/16 ORB
5500 SA	116658	14 Gal	3250 PSI	1 1/16 ORB
6600 DA	116657	14 Gal	3250 PSI	1 1/16 ORB
6600 SA	116658	14 Gal	3250 PSI	1 1/16 ORB
7700 DA	116657	14 Gal	3250 PSI	1 1/16 ORB
7700 SA	116658	14 Gal	3250 PSI	1 1/16 ORB

NOTES

SPECIALLY DESIGNED – WITH QUALITY IN MIND

CUSTOMER SATISFACTION PLEDGE

Crysteel's Customer Satisfaction Pledge is designed to be the most comprehensive warranty in the truck equipment industry. This pledge covers new products for a period of five (5) years, and is not restricted by vehicle mileage or when product is invoiced to our distributors. Our warranty begins when our product is put into service by the final customer.

This warranty covers our products for defective material and/or workmanship at a rate of 100 % for the first (3) years and at a rate of 50 % for years 4 and 5. This warranty covers:

- Crysteel Manufactured product
- OEM Products purchased by Crysteel as part of our product
- The repair of warranted product
- The replacement of warranted product
- Labor to replace warranted product
- Freight for replacement product
- Warranted product return freight (if required)

This warranty is limited to product supplied under the Crysteel Mfg. name and does not cover distributor modifications. Repair or replacement is at Crysteel's option. Primer warranty is limited to adherence to metal surfaces only and does not include the inside or understructure of dump bodies. Crysteel will not assume responsibility for travel, loss of use, downtime expenses or other incidental or consequential damages. This warranty is void if the product has been obviously abused or subjected to other than normal usage. There are no other warranties except as described above, and Crysteel makes no warranty of fitness for a particular purpose.

! CAUTION !

- **BODY MUST BE BRACED BEFORE SERVICING HOIST OR WORKING IN AREA WITH BODY IN RAISED POSITION**
- **LUBRICATE HOIST GREASE FITTINGS OFTEN – AT LEAST EACH TIME TRUCK IS SERVICED**
- **TRUCK MUST BE LEVEL FOR DUMPING**
- **DO NOT OVERLOAD**

CRYSTEEL MFG, INC.

CRYSTEEL MANUFACTURING, INC.

P.O. Box 178 52182 Ember Road
Lake Crystal, MN 56055

1902 Route 57 South
Fulton, NY 13069

(507) 726-2728 (800) 533-0494