

OWNERS
MANUAL

CRYSTEEL'S

COBRA

HOIST

MOUNTING AND OPERATING INSTRUCTIONS



HIGHWAY 60 EAST
LAKE CRYSTAL
MINNESOTA 56055
TELEPHONE 507-726-2728
OUT OF MN 800-533-0494

DATE PURCHASE _____
 HOIST SERIAL NUMBER _____
 CYLINDER SERIAL NUMBER _____
 DEALER _____
 ADDRESS _____
 PHONE _____

TABLE OF CONTENTS

Purchase Record Inside Front Cover
 Foreword 2
 Warranty 2

OPERATION AND MAINTENANCE

 Operation and Use 3
 Some Do's and Don'ts for Safety and Long Service 3

INSTALLATION INSTRUCTIONS

 Complete Cylinder Instructions 4
 Mount the Rear Hinge 4
 Locate Hoist on Truck Frame 5
 Mount Hoist to Truck Frame 7
 Mount Pump 7
 Install Driveshaft 8
 Install Control Cable 8
 Install Hoses-Single-Acting 9
 Install Hoses-Double-Acting 9
 Install Hoses - 1100, 1500, 1900 10
 Add Hydraulic Oil 10
 Grease Hoist 11
 Mount Body 11
 Install Body Prop 11
 Bleed Cylinders 12
 Install Decals 12

ROUTINE MAINTENANCE

 Lubricate Regularly 13
 Change Hydraulic Oil 13
 Lubricate Valve Control Cable 13

PARTS LIST 14

FOREWORD

The Cobra twin cylinder underbody hoist is designed for use on single and tandem axle trucks with 12 to 28 foot bodies. The Cobra hoist line consists of 8 models ranging from Model 1100 in NTEA class D to the Model 7700 in NTEA class L.

This manual contains all the information needed for the proper installation and operation of these hoists. Study it carefully before attempting to install or operate this product. With the proper installation, use and regular maintenance, Crysteel's Cobra hoist will give many years of trouble free service.

WARRANTY

- Crysteel Manufacturing, Inc. warrants its products for a period of one year from date of purchase.
 - The warranty provides that our products must perform satisfactorily or we will repair, replace or refund the purchase price at the option of the purchaser. Hydraulic pumps, valves, hoses and other purchased parts are covered by the warranties of their respective manufacturers.
 - Any parts returned to Crysteel Manufacturing, Inc. shall be shipped prepaid, and will be returned F.O.B. Lake Crystal, Minnesota.
 - We will not assume responsibility for shipping, labor or travel expenses.
 - The warranty is void if the product has been obviously abused, or subjected to other than normal usage.
 - We reserve the right to make improvements without notice or obligation regarding models previously sold.
-

OPERATION AND MAINTENANCE INFORMATION

OPERATION AND USE

1. Engage PTO from cab and adjust engine speed to fast idle.
2. To raise the hoist, pull the hoist control knob out. To hold the body in a raised position, return the hoist control knob to the center detent position.
3. To lower the hoist, push the hoist control knob in. Always return the hoist control knob to the center detent position after the body is all the way down.
4. **DO NOT LEAVE THE PTO IN GEAR WHILE TRANSPORTING. THIS WILL CAUSE SEVERE DAMAGE TO THE HYDRAULIC PUMP AND/OR DRIVELINE.**
5. The hydraulic system should be drained, flushed and refilled with proper hydraulic fluid at regular intervals. **CAUTION: NEVER** use hydraulic brake fluid in the hydraulic system.

SOME DO'S AND DON'T'S FOR SAFETY AND LONG SERVICE

1. **NEVER** operate the hoist control valve from outside the cab.
2. Use the proper hydraulic fluid. **KEEP IT CLEAN.** Remember to change it regularly.
3. Lubricate all grease fittings at regular intervals.
4. **ALWAYS** carefully block up the body, using the body prop, before working under it.
5. Do not "race" the engine when unloading.
6. Do not load the hoist beyond its capacity.
7. **DO NOT** tamper with the hydraulic relief valve. This will void the warranty. It can cause severe damage to the hoist and cylinder.
8. Never leave the PTO in gear while transporting. It will ruin the hydraulic pump.
9. Check all bolts and set screws regularly. Keep them tight.

**NEVER EXCEED THE G.V.W. (GROSS VEHICLE WEIGHT) RATING NOR THE G.A.W.
(GROSS AXLE WEIGHT) RATING SPECIFIED FOR YOUR TRUCK**

INSTALLATION INSTRUCTIONS

COMPLETE CYLINDER INSTALLATION

Place the hoist upside down on the floor. The cylinders have been installed in the cylinder mounting sleeves. They need to be bolted to the crossheads. Rotate the inner tubes so the bleed plug is down for single-acting cylinders. On double-acting cylinders the head ports should be toward the center of the hoist for hoist models 2200 through 7700. Lift the base end of the cylinders to align the cylinders with the crossheads. (The hoist may need to be opened slightly to do this.) Bolt the cylinders to the crossheads using $3/8 \times 1\ 1/2$ cap screws, lock washers and hex nuts. Check the cylinder mounting screws; they should be tight.

MOUNT THE REAR HINGE

The rear hinge must be located as close as possible behind the rear spring hanger. This will be 32 to 36 inches behind the center of the rear axle on single axle trucks and 42 to 50 inches behind the center of the tandem on tandem axle trucks. Mark the rear of the truck frame for notching as shown, leaving enough of the bottom flange of the truck frame to be bent up later to box in the truck frame. Notch the truck frame as marked.

Make sure the rear hinge is square with the truck frame and at the correct height. The top surface of the rear hinge bracket should be flush with the top of the angle mounting brackets of the hoist frame. Securely weld the rear hinge to the truck frame. Bend the bottom flange of the truck frame up and weld all around to box in the truck frame.

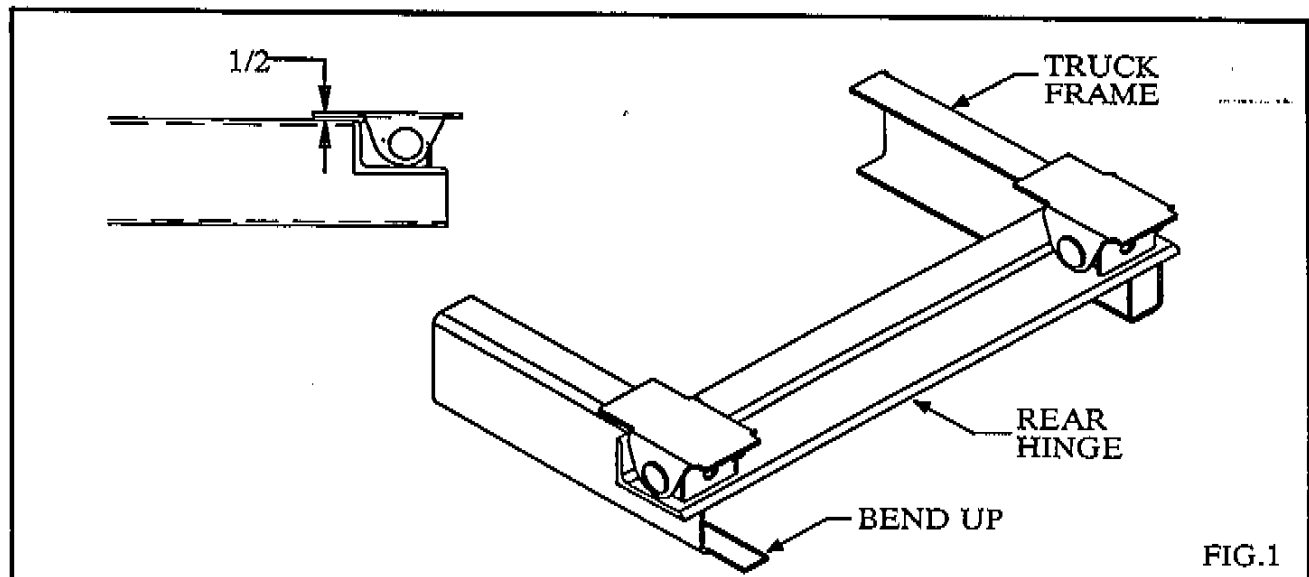

LOCATE HOIST ON TRUCK FRAME

Find the "D" dimension in TABLE 1 below for the hoist model and desired dump angle. Using this dimension, measure forward from the center of the rear hinge and mark the truck frame. Place the hoist on the truck frame. (See Fig. 2) Center the front cross tube of the hoist over the mark on the truck frame. Be sure to allow enough room for the cylinders to swing as the body is raised. Make sure the hoist is centered on and square with the truck frame. The angle mounting brackets must rest flat on the truck frame. If rivets are encountered in the truck frame, and the hoist cannot be moved to clear them, countersink the rivet heads into the brackets. The rear end of the main hoist frame is designed to rest on a crossmember in the truck frame. If no crossmember exists to support the hoist frame, add one.

Note: In some cases the hoist may fit the truck frame better if it is mounted reversed or "backwards" as shown in Figure 3. When mounting the hoist "backwards" be sure to measure to the front crosstube of the hoist as shown in Figure 3 and to allow enough room for the cylinders to swing as the body is raised.

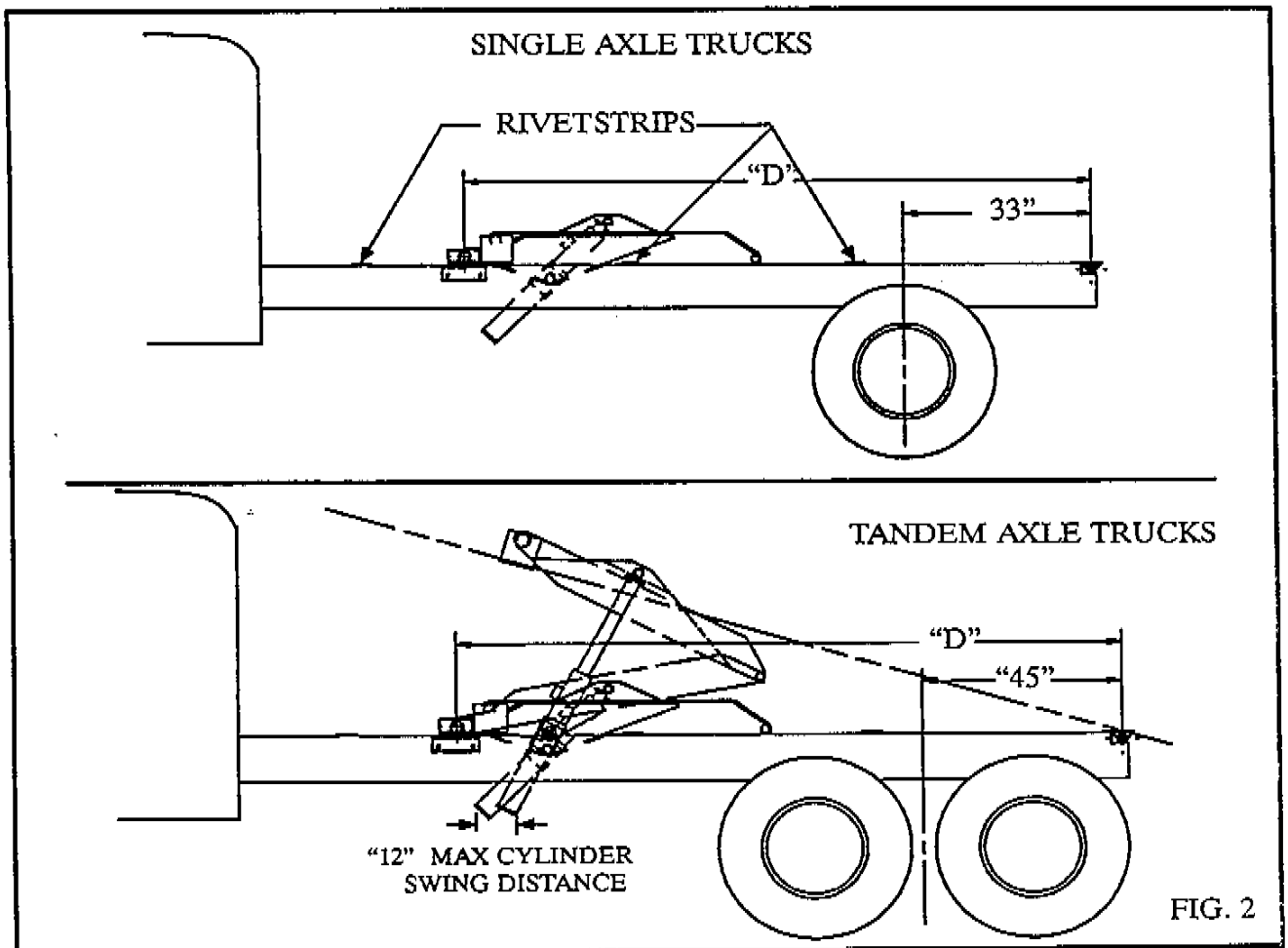

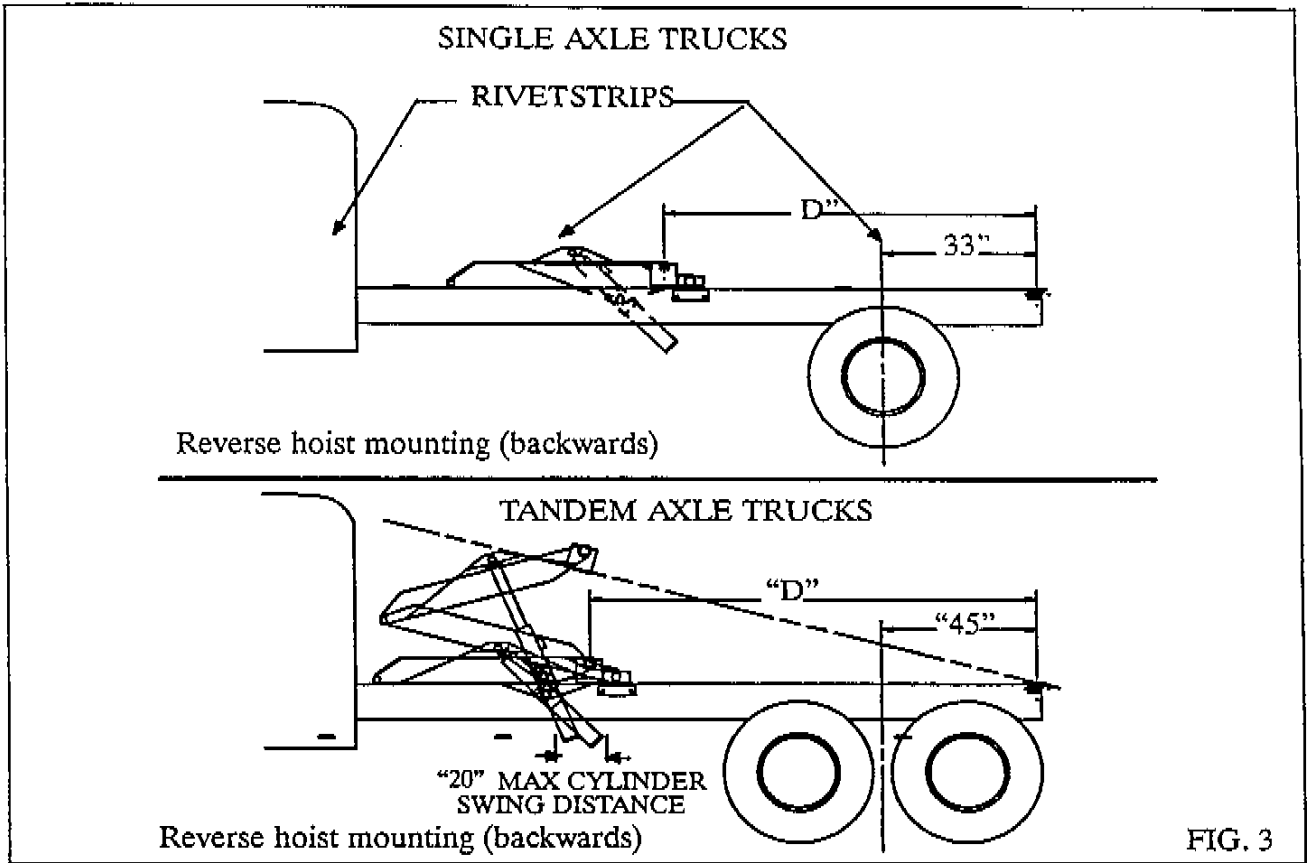
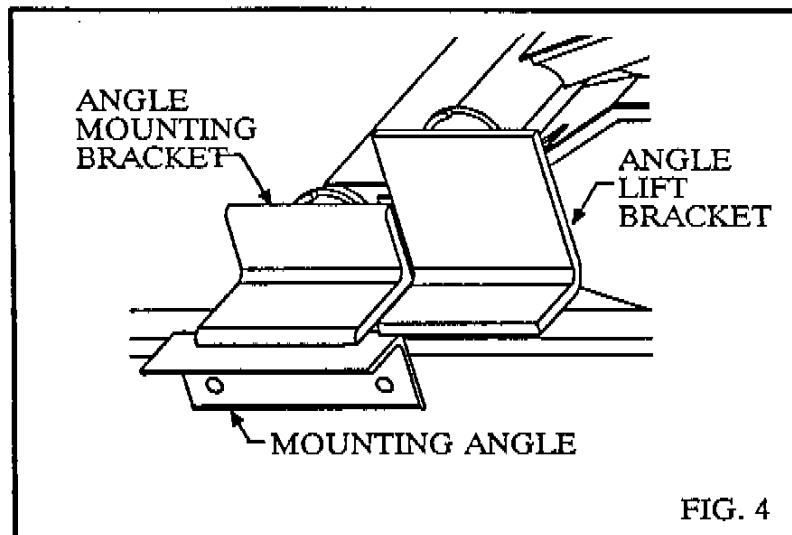

TABLE 1

MODEL	DUMP ANGLE			
	40°	45°	50°	55°
1100	113"	97"	88"	81"
1500	113"	97"	88"	81"
1900	113"	97"	88"	81"
2200	136"	123"	111"	102"
3300	136"	123"	111"	102"
4400	136"	123"	111"	102"
5550	168"	149"	136"	125"
6660	188"	167"	152"	140"
5500	171"	153"	140"	128"
6600	191"	171"	156"	143"
7700	208"	186"	169"	155"

MOUNT HOIST TO TRUCK FRAME

Center the mounting angles under the angle mounting brackets on the hoist. Clamp them in place and mark the truck frame for drilling, using the mounting angles as guides. (See Fig. 4)



CAUTION: WHEN DRILLING IN TRUCK FRAME BE CAREFUL OF BRAKELINES, WIRING, ETC, INSIDE THE TRUCK FRAME.

Drill $21/32$ inch holes in the truck frame and bolt the mounting angles in place using $5/8 \times 1 \ 3/4$ cap screws, lock washers and hex nuts. Securely weld the angle mounting brackets to the mounting angles.

MOUNT PUMP

Determine which side of the truck frame to mount the pump (same side as the PTO opening on the transmission). Bolt the mounting angles to the pump using $3/8 \times 1$ cap screws, flat washers, lock washers and hex nuts. Clamp the pump mounting angles to the truck frame with the pump inside the truck frame a few inches behind the cab. (See Figure 5) Check that the PTO drive shaft is long enough and does not exceed 15° in angularity. Check for sufficient clearance around the pump. Reposition the pump for the best location. Be sure the PTO shaft and the pump shaft are parallel. This improves the life expectancy of the U-Joints. In some cases, it may be necessary to rework the exhaust system for sufficient clearance around the pump.

NOTE: UNDER NO CIRCUMSTANCES SHOULD THE ENGINE EXHAUST BE PERMITTED TO BLOW DIRECTLY ONTO THE PUMP!

After locating the pump, drill $17/32$ holes through the truck frame and bolt in place using $1/2 \times 1 \ 3/4$ cap screws, lock washers and hex nuts (See caution note above).

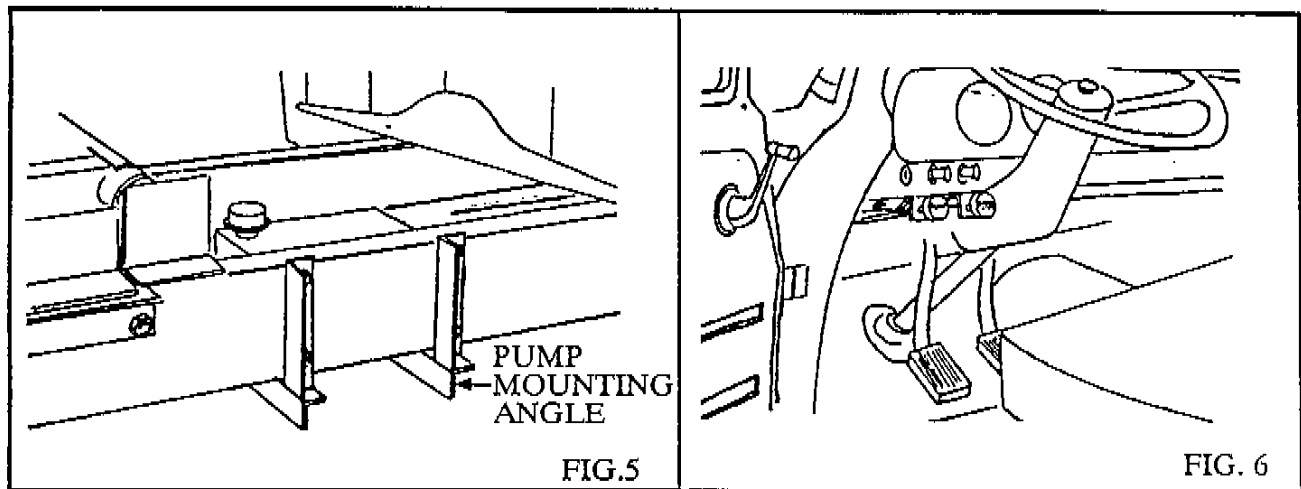

INSTALL DRIVESHAFT

Install the long U-joint on the pump drive shaft and the short U-joint on the PTO drive shaft so that the inner edge of the hub of each is flush with the end of the shaft. **DO NOT TIGHTEN THE SET SCREWS!** Measure the distance from the inner edge of the hub of one U-joint to the inner edge of the hub of the other U-joint. This is the length that the drive shaft needs to be. Cut the drive shaft to proper length with a hacksaw and deburr. Install the drive shaft and tighten all set screws. Re-tighten the set screws and secure them with a safety wire.

INSTALL CONTROL CABLE

Remove the control wire from the control cable housing and oil the inside of the cable housing and reassemble. Attach the control mounting angle at a convenient location under the dash using 1/4 x 3/4 cap screws, lock washers and hex nuts. (See Fig. 6.) Insert control cable through a hole in the firewall, and attach control knob end of the cable to the control mounting angle. The valve control cable has a detent lock to keep the control valve in neutral when it is not being used. Place the control cable in the center detent position and attach the other end to the valve control lever on the pump using the parts supplied. The control valve should be in neutral when the control cable is attached. Check for proper operation and adjust if necessary. Be sure that there are no sharp bends in the control cable. Keep the control cable away from hot exhaust pipes. After the cable is properly adjusted, install the valve guard on the pump.

NOTE: It is extremely important that the valve guard cover remain in place. It should be removed **ONLY** for lubrication or adjustment of the lever or cable, then replaced immediately. It protects the lever and cable from the weather and corrosion. It also prevents operation of the valve from outside the cab. **NEVER**, under any circumstances, try to operate the valve manually from outside the cab.

INSTALL HOSES - SINGLE ACTING MODELS 3300 - 7700

Please study Figure 7 very carefully before installing the hoses. Install a 90° street elbow in the valve port. Connect a 60" long 1/2" I.D. hose from the valve to the reducing pipe tee. Connect an 18" long 3/8" I.D. hose from the reducing pipe tee to one of the cylinders and connect a 24" long 3/8" I.D. hose from the reducing pipe tee to the other cylinder.

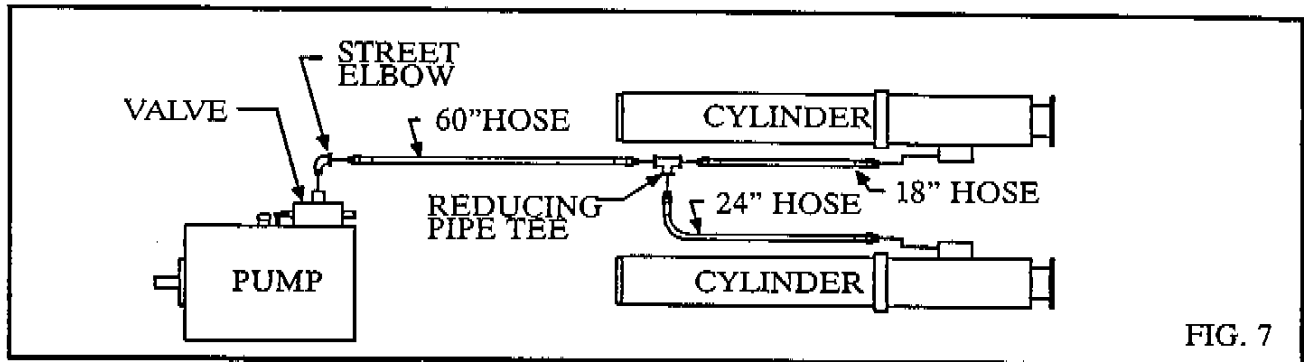

INSTALL HOSES - DOUBLE ACTING MODELS 2200 - 7700

Please study Figure 8 very carefully before installing the hoses. Install 90° street elbows in both work ports of the control valve. Install 90° street elbows in the ports on the bottom end of the cylinders. Connect a 48" long hose from the rear port on the control valve to the pipe tee. Connect a 24" hose from the pipe tee to the base end port of one cylinder and connect a 30" hose from the pipe tee to the base end port of the other cylinder.

There is plumbing inside the hoist frame for the power down function of the hoist. Connect a 36" long hose from the front port on the control valve to the pipe elbow near the front of the hoist frame. Connect 18" long hoses from the elbows on the upper frame to the ports on the top end of the cylinders. When the hoses are connected properly, the hoist should raise when the control knob is pulled out and lowered when it is pushed in.

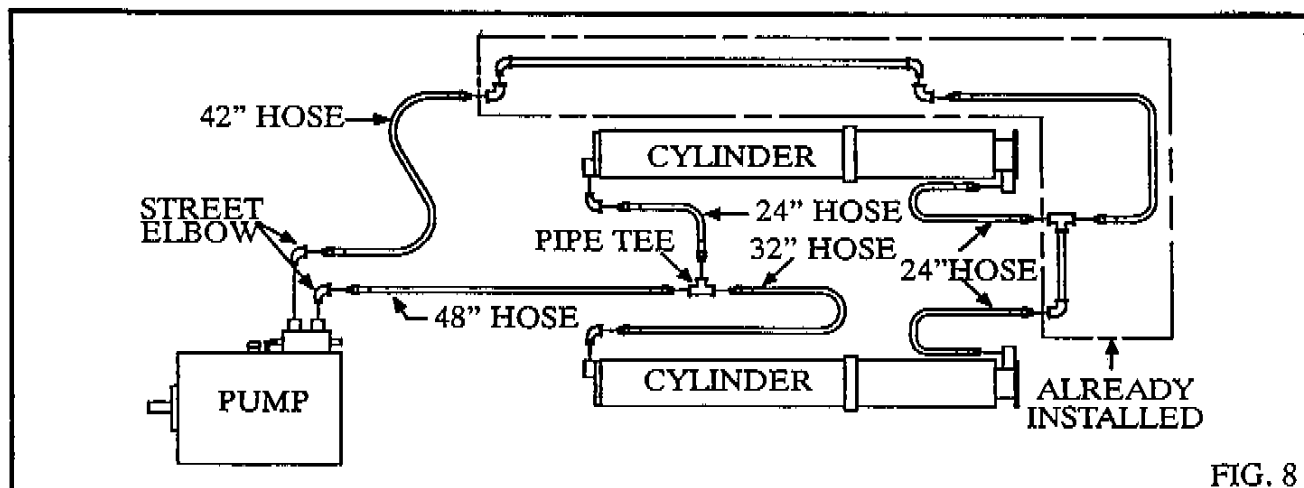

INSTALL HOSES - MODELS 1100, 1500, 1900

Please study Figure 9 very carefully before installing the hoses. Install 90° street elbows in both work ports of the control valve. Install 90° street elbows in the ports on the bottom end of both cylinders. Connect a 60" long hose from the rear port on the control valve to a pipe tee. Connect 18" long hoses from the pipe tee to the ports on the bottom end of the cylinders. Connect a 60" hose from the front port on the control valve to a second pipe tee. Connect 18" long hoses from the second pipe tee to the ports on the top end of the cylinders. Secure the 18" hoses to the cylinder mount using the tie straps provided. When the hoses are connected properly, the hoist should raise when the control knob is pulled out and lowered when it is pushed in.

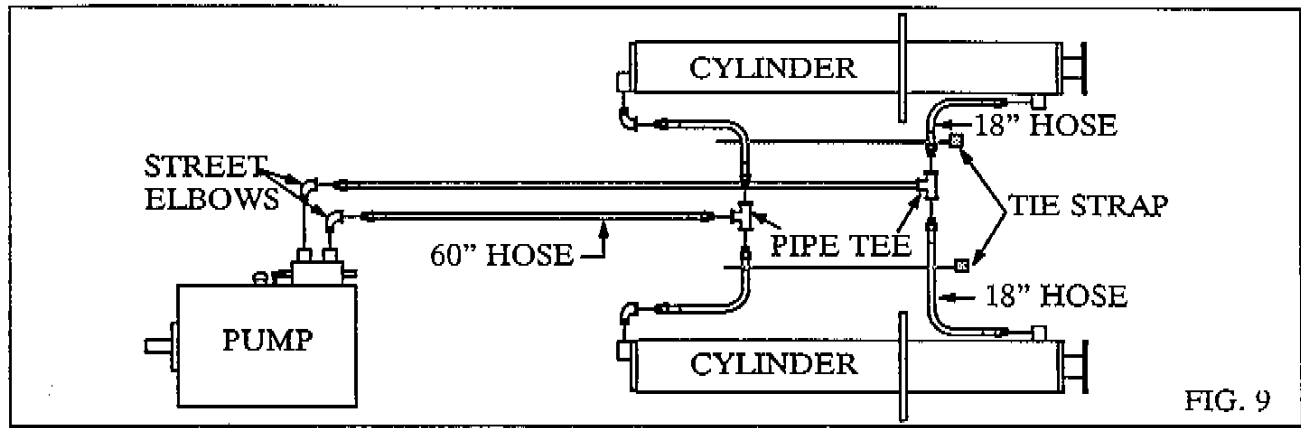

ADD HYDRAULIC OIL

Refer to TABLE 2 below for the amount of hydraulic oil required to operate the hoist. Use a quality hydraulic fluid of 150 SSU @ 100°F. which contains corrosion and oxidation inhibitors and a foam depressant. This is approximately the equivalent of SAE 10W or lighter weight oil, or use Type A automatic transmission fluid for improved performance in cold weather.

TABLE 2

HOIST MODEL	RESERVOIR SIZE	OIL REQUIRED	HOIST MODEL	RESERVOIR SIZE	OIL REQUIRED
1100	15QT	9 QTS	4400	27QT	27QTS
1500-4	15QT	11QTS	5500	42QT	34QTS
1500-8	21QT	13QTS	5550	27QT	24QTS
1900	21QT	15QTS	6600	42QT	34QTS
2200	21QT	14QTS	6660	42QT	35QTS
3300	27QT	20QTS	7700	42QT	42QTS

GREASE HOIST

Install grease zerks and lubricate in the following locations:

A. Upper Crosstube	2 fittings
B. Lower Crosstube	2 fittings
C. U-Joints	3 fittings (2 already installed)
D. Body Props	2 fittings
E. Rear Hinge	2 fittings (already installed)

Lubricate all fittings at regular intervals, at least every 200 cycles or 2 months. There are very high forces on the bearing surfaces within the hoist frame. It pays to be generous in lubricating the hoist to ensure proper operation and long life.

NOTE: The crossheads, the lower cylinder mount pivots and the center hinge of the hoist are equipped with self lubricating composite bearings. These points do not need to be greased.

MOUNT BODY

It is recommended that the body be painted before it is mounted on the truck. Place the body in position on the truck with three inches of clearance behind the cab. Use the rivet strip mounting pads between the longbeams and the truck frame. Use three on each side, spaced as seen on Fig. 2 on Page 5. Weld them to the longbeams. Align body longbeams carefully with the truck frame. Securely weld the longbeams to the rear hinge brackets.

Weld the longbeams securely to the angle lift brackets of the hoist. On the inside of the longbeams, securely weld the flat spacer to the top of the angle lift bracket and to the top flange of the longbeam channels. For Crysteel's new grain body, place the 9 inch square plate between the angle lift bracket and the inside of the longbeam. Securely weld this plate to the longbeam and to the angle lift bracket. Be sure to do this on both sides.

INSTALL BODY PROP

The body prop is designed and intended to support an EMPTY truck body in the raised position. Use of the body prop permits service to be performed safely beneath a raised body. One body prop is included with Cobra Hoist models 1100 through 1900; two body props (one pair) are included with models 2200 through 7700. Be sure to install each prop on the correct side of the truck as explained below.

1. Raise the body to a 30° to 35° angle and brace it securely before beginning installation.
2. Assemble the prop arm to the prop pivot mount with a 1/4 x 3 roll pin. Clamp the prop pivot mount against the outside of the truck frame just behind the rear axle. Raise the body prop arm to a free standing position. Reposition the prop pivot mount so the body prop arm lines up with the tube welded into the longbeam of the body. It may be necessary to raise or lower the body to get the best location for the prop pivot mount. Using the prop pivot mount as a guide, mark the location of holes on the truck frame and drill 17/32 inch holes. Assemble the prop pivot mount to the frame using 1/2 x 1 3/4 cap screws, lock washers and hex nuts.

3. When mounting two body props, repeat steps 1 and 2 for the other side. Use the body prop already mounted to assure that both body props hold the body at the same height. The left and right body props should pivot toward the front of the truck in the storage position.
4. To operate the body prop, raise the body to the desired height, shut off all power, raise the prop arm to a free standing position. Lower the body slowly until the tube welded into the longbeam contacts the prop arm saddle. **DO NOT POWER HOIST DOWN.**
5. To place the body prop in the storage position, raise the body to clear the body prop saddle, lower the body prop to the storage position and lower the body.

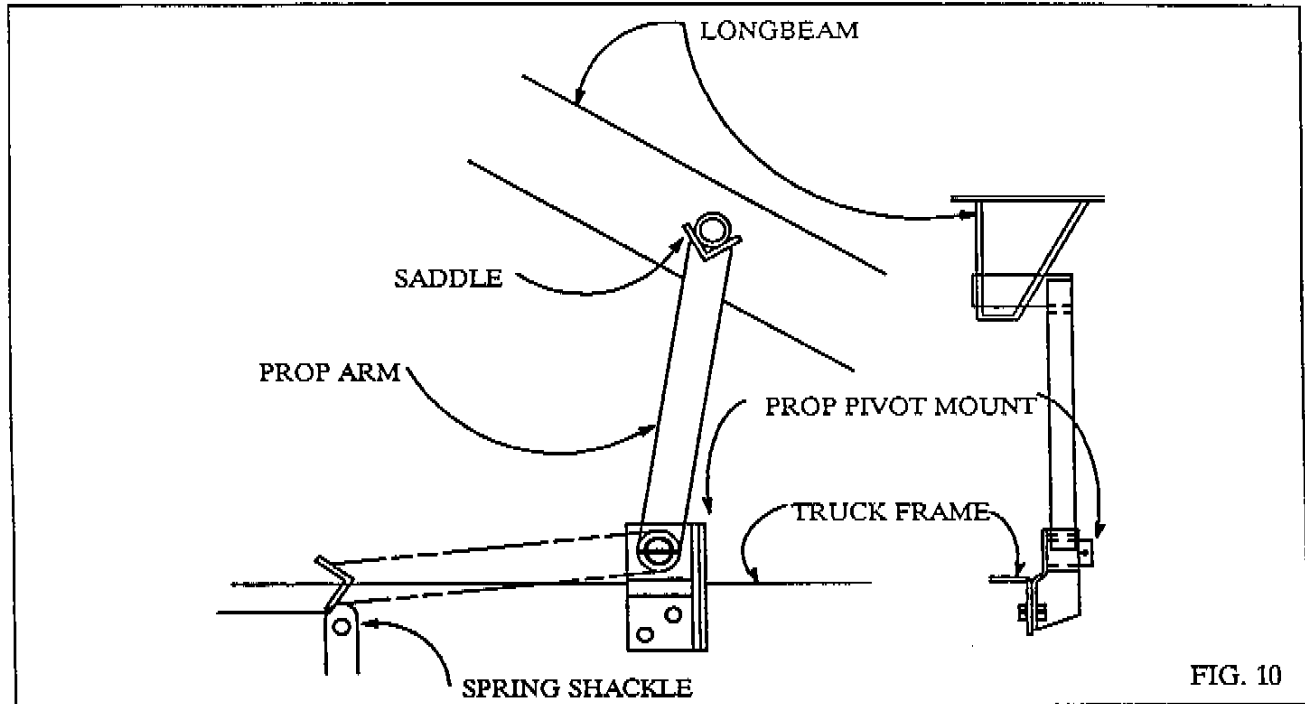

BLEED CYLINDERS - SINGLE-ACTING

After the body and the body prop have been installed, use the hoist to raise the body to its full height. Shut off the engine and place the control valve in neutral. Raise the body props to their support positions. Lower the body to within four inches of the body props. Very carefully, slowly loosen the bleed plug on the top end of one of the cylinders - **DO NOT REMOVE IT!** When oil starts seeping out around the bleed plug, tighten it. Repeat this for the other cylinder. After both cylinders have been bled, raise the body, lower the body prop and lower the body.

NOTE: Double-acting cylinders do not have a bleed plug because they bleed themselves in use. Cycle the hoist several times to remove any air from the cylinders.

INSTALL DECALS

There are three decals to be placed on the body and one decal to be placed in the cab. Place the large **CAUTION** decal and the **BODY PROP OPERATION** decal on the longbeam near the body prop. Place the small **BODY PROP CAUTION** decal on the body prop arm. Place the small **CAUTION** decal in the truck cab in a prominent location.

ROUTINE MAINTENANCE

LUBRICATE REGULARLY

Install grease zerks and lubricate the Cobra Hoist in the following locations:

- A. U-joint 3 fittings
- B. Body Prop 2 fittings
- C. Upper Crosstube 2 fittings
- D. Lower Crosstube 2 Fittings

Lubricate all fittings at regular intervals, at least every 200 cycles or 2 months. There are very high forces on the bearing surfaces within the hoist frame. It pays to be generous in lubricating the hoist to ensure proper operation and long life.

NOTE: The crossheads, the lower cylinder mount pivots and the center hinge of the hoist are equipped with self lubricating composite bearings. These points do not need to be greased.

CHANGE HYDRAULIC OIL

With normal use and working conditions the hydraulic oil should be changed annually. The breather cap should be cleaned regularly. With heavy use or very dusty working conditions the hydraulic oil should be changed more often.

KEEP THE OIL CLEAN! USE CLEAN CONTAINERS, FUNNELS AND OTHER EQUIPMENT!

Use a quality hydraulic fluid of 150 SSU @ 100° F. which contains corrosion and oxidation inhibitors and a foam depressant. This is approximately the equivalent of SAE 10W or lighter weight oil, or use Type A automatic transmission oil for improved performance in cold weather. Refer to chart on page 10 for the amount of oil needed.

LUBRICATE VALVE CONTROL CABLE

With normal use and working conditions the control cable should be oiled annually. With heavy use or very dusty conditions it should be oiled more often. Raise the body and rest it on the body props. Remove the valve guard cover. Disconnect the control cable from the control valve lever, remove the control wire from the control cable housing and oil the inside of the control cable housing. Reinsert the control wire in the control cable housing to center detent position and reattach the control cable to the control valve lever. Check for proper operation and adjust if necessary. Reinstall the valve guard on the pump.

NOTE: It is extremely important that the valve guard cover remain in place. It should be removed ONLY for lubrication or adjustment of the lever or cable, then replaced immediately. It protects the lever and cable from the weather and corrosion. It also prevents operation of the valve from outside the cab. NEVER, under any circumstances, try to operate the valve manually from outside the cab.

COBRA PARTS LIST

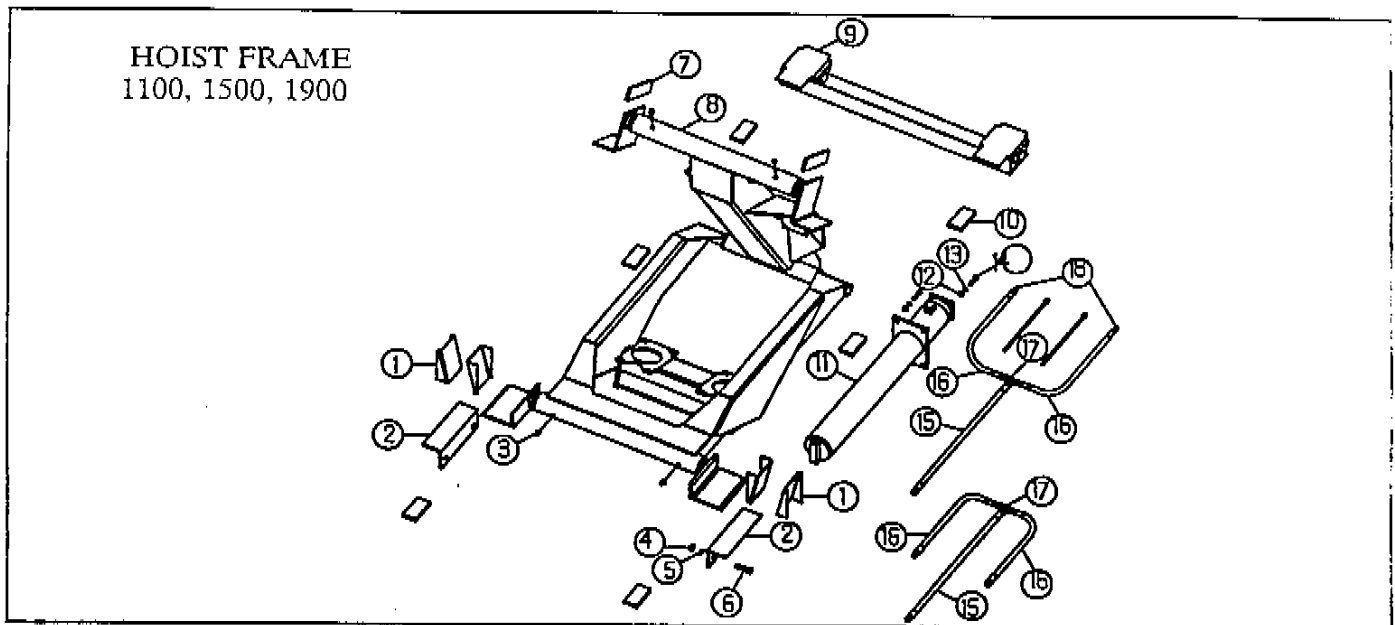

FRAME PARTS LIST 1100-1500-1900

ITEM	PART NO.	DESCRIPTION	QTY.
1.	201415	Body Guide	4
2.	201422	Mounting Angle	2
3.	400103	Grease Zerk	4
4.	400181	Hex Nut 5/8 NC	4
5.	400160	Lock Washer 5/8	4
6.	400100	Hex Cap Screw 5/8 NC X 1 3/4	4
7.	200900	Longbeam Filler	2
8.	113336	Hoist Frame - 1100	1
	111716	Hoist Frame - 1500	1
	112972	Hoist Frame - 1900	1
9.	106060	Rear Hinge	1
10.	200892	Longbeam Spacer	6
11.	113337	Cylinder - 1100	1
	112138	Cylinder - 1500	1
	111717	Cylinder - 1900	1
12.	400183	Hex Nut 3/8 NC	16
13.	400162	Lock Washer 3/8	16
14.	400114	Hex Cap Screw 3/8 NC x 1 1/2	16
15.	400515	Hose 3/8 NPT x 60	2
16.	400509	Hose 3/8 NPT x 18	4
17.	400416	Tee 3/8 NPT	2
18.	401542	Tie Strap	2

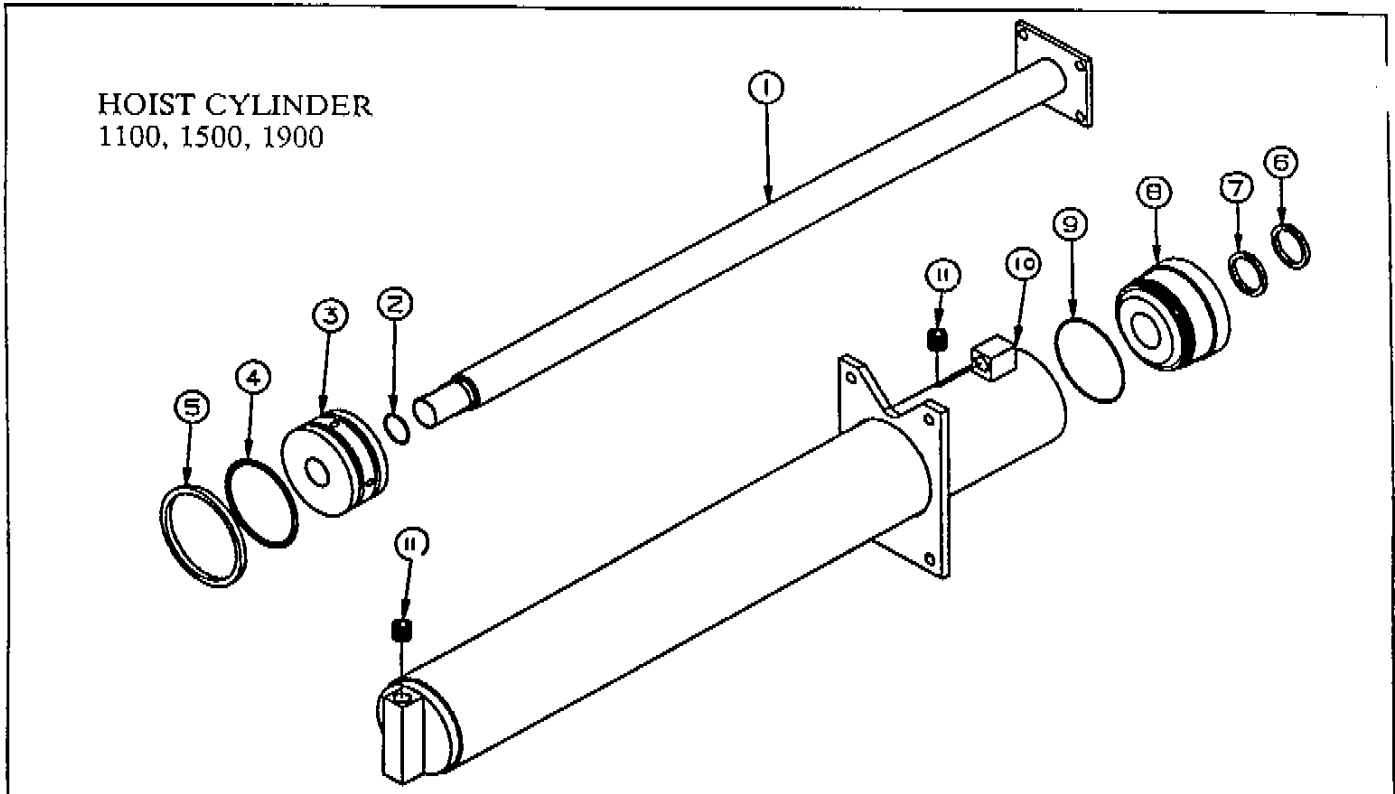

HOIST PARTS	1100	1500	1900
1. SHAFT ASSY	112141	112141	112141
2. O-RING*	401131	401131	401131
3. PISTON	216599	215364	214838
4. O-RING*	401639	401633	401616
5. POLYSEAL*	401638	401634	401646
6. WIPER SEAL	401617	401617	401617
7. POLYSEAL*	401132	401132	401132
8. HEAD	216014	215363	214837
9. O-RING*	401664	401634	400957
10. OUTER TUBE ASSY	113391	112140	111721
11. PIPE PLUG 3/8"	400222	400422	400422
12. SEAL KIT (includes items with *)	113477	113478	113479

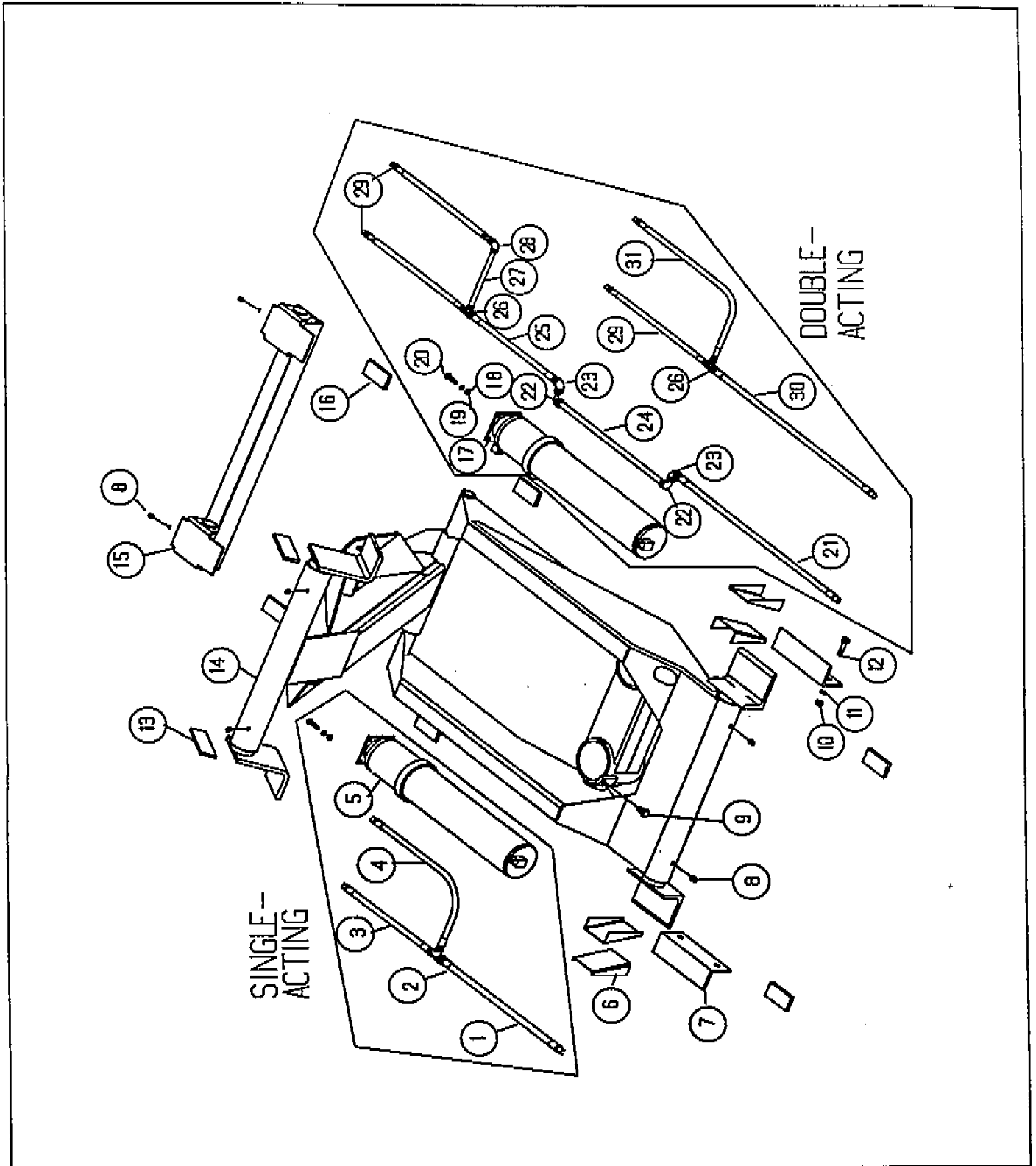

COBRA FRAME PARTS LIST

ITEM	PART NO.	DESCRIPTION	QTY.
1.	401502	Hose 1/2 NPT x 60"	1
2.	401503	Tee, Reducing 1/2 x 3/8 x 3/8	1
3.	400509	Hose, 3/8 NPT x 18"	1
4.	400510	Hose 3/8 NPT x 24"	1
5.	110023	Cylinder, SA 3300	2
	110028	4400	2
	109567	5500	2
	109101	5550	2
	110295	6600	2
	110296	6660	2
	110374	7700	2
6.	201415	Body Guide	4
7.	201422	Mounting Angle, Truck Frame	2
8.	400103	Grease Zerk, 1/8 NPT	6
9.	401612	Retaining Screw	2
10.	400181	Hex Nut 5/8-11	4
11.	400160	Lock Washer 5/8	6
12.	400100	Hex Cap Screw 5/8-11 x 1 3/4	4
13.	200896	Longbeam Filler	2
14.	110016	Hoist Frame 2200DA	1
	110021	3300SA	1
	111348	3300DA	1
	110026	4400SA	1
	111349	4400DA	1
	109655	5500SA	1
	111350	5500DA	1
	108765	5550SA	1
	111351	5550DA	1
	110293	6600SA	1
	111352	6600DA	1
	110294	6660SA	1
	111353	6660DA	1
	110373	7700SA	1
	111354	7700DA	1
15.	107073	Rear Hinge	1
16.	200890	Longbeam Spacer	6
17.	110018	Cylinder. DA 2200	2
	111072	3300	2
	111073	4400	2

COBRA FRAME PARTS CONTINUED

17.	111074	Cylinder , DA	5500	2
	111075		5550	2
	111076		6600	2
	111077		6660	2
	111078		7700	2
18.	400183	Hex Nut 3/8-16		8
19.	400162	Lock Washer 3/8		8
20.	400114	Hex Cap Screw 3/8-16 x 1 1/2		8
21.	400513	Hose 3/8 NPT x 42"		1
22.	400512	Street Elbow 3/8		2
23.	400413	Elbow 3/8		2
24.	401521	Pipe 3/8 x 34"	2200DA, 3300DA, 4400DA	1
	401597	Pipe 3/8 x 46"	5500DA, 5550DA	1
	401598	Pipe 3/8 x 55"	6600DA, 6660DA	1
	401599	Pipe 3/8 x 62"	7700DA	1
25.	400510	Hose 3/8NPT x 24"	2200DA, 3300DA, 4400SA	1
	400512	Hose 3/8 x 36"	5500DA, 5550DA	1
	400513	Hose 3/8 x 42"	6600DA, 6660DA	1
	400514	Hose 3/8 x 48"	7700DA	1
26.	401519	Tee, Reducing 3/8 x 1/4 x 1/4		2
27.	401520	Pipe 1/4 x 9"		1
28.	400417	Elbow 1/4		1
29.	400516	Hose 1/4 NPT x 24"		3
30.	400514	Hose 3/8 NPT x 48"		1
31.	400947	Hose 1/4 NPT x 32"		1

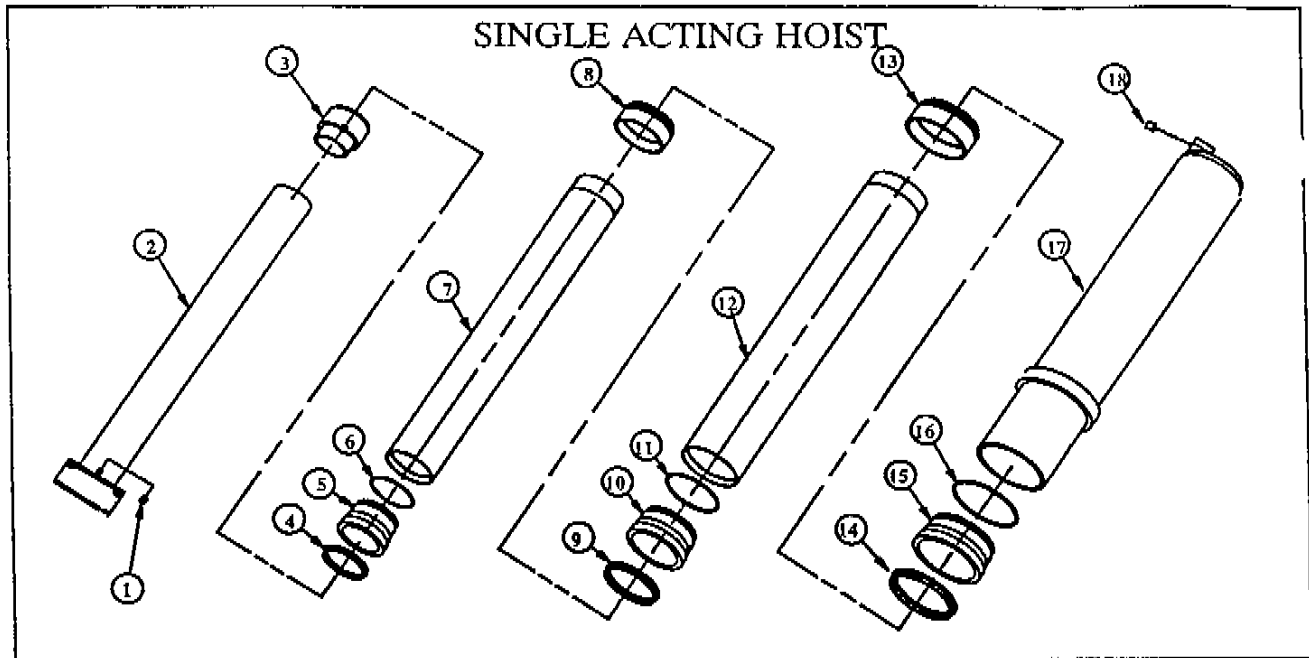

SINGLE ACTING HOIST 3300-7700							
	3300	4400	5500	5550	6600	6660	7770
1. PIPE PLUG 1/8 NPT	400477	400477	400477	400477	400477	400477	400477
2. INNER TUBE ASSY	110172	110030	110172	110160	110298	110300	110375
3. INNER PISTON	213683	213684	213683	213683	213683	213684	213683
4. POLYSEAL 2 3/4ID X 3/16	401461	---	401461	401461	401461	---	401461
5. HEAD 3 1/2 OD	213317	---	213317	213317	213317	---	213317
6. O-RING 2 7.8ID X .070	400956	---	400956	400956	400956	---	400956
7. TUBE 3 1/2 OD	213404	---	213404	213327	213621	---	213327
8. PISTON 3 3/4 OD	211750	---	211750	211750	211750	---	211750
9. POLYSEAL 3 1/2ID X 3/16	401462	401462	401462	401462	401462	401462	401462
10. HEAD 4 1/4 OD	213318	213318	213318	213318	213318	213318	213318
11. O-RING 4 1/4 ID	400957	400957	400957	400957	400957	400957	400957
12. TUBE 4 1/4 OD	---	213405	213405	---	213622	213625	213328
13. PISTON 4 1/4 OD	---	211751	211751	---	211751	211751	211751
14. POLYSEAL 4 1/4ID X 3/16	---	401463	401463	---	401463	401463	401463
15. HEAD 5 OD	---	213319	213319	---	213319	213319	213319
16. O-RING 4 1/4OD X .070	---	400958	400958	---	400958	400958	400958
17. OUTER TUBE ASSY	111079	111080	111080	111082	111083	111084	111085
18. PIPE PLUG 3/8 NPT	400422	400422	400422	400422	400422	400422	400422

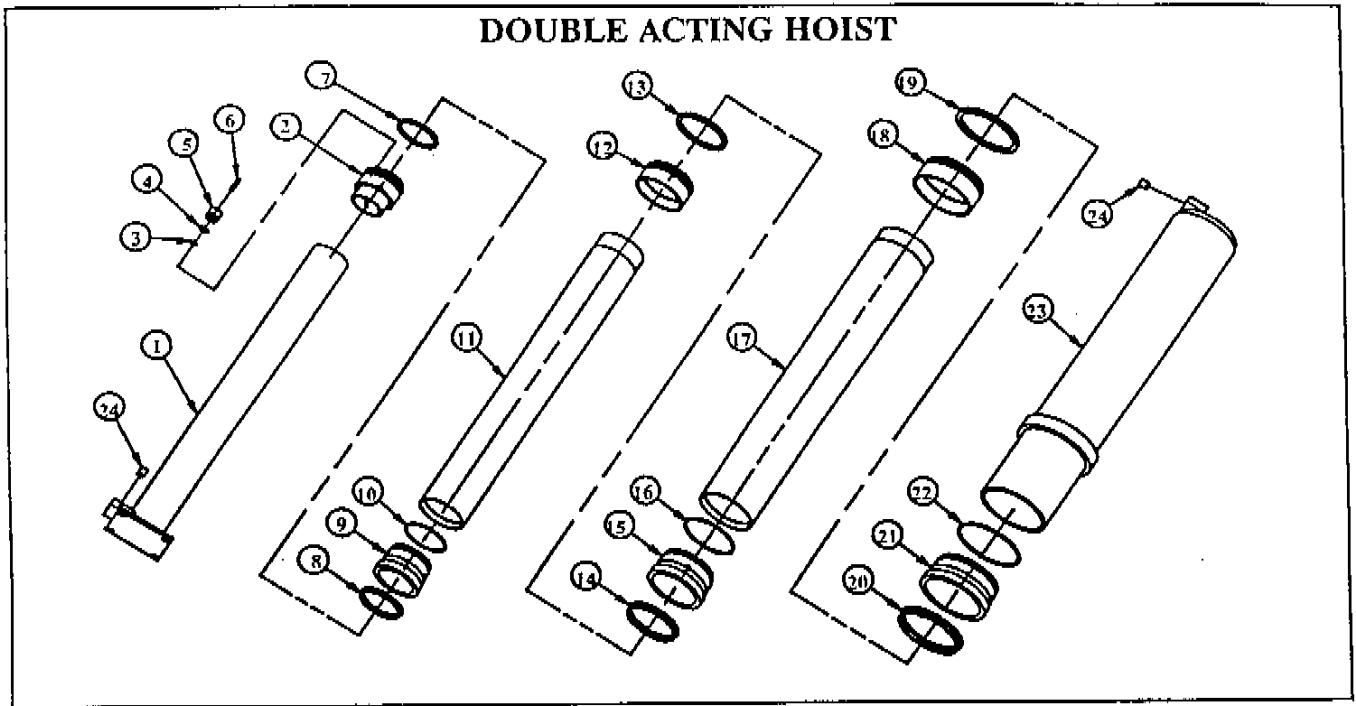

DOUBLE ACTING HOIST 2200-7700								
	2200	3300	4400	5500	5550	6600	6660	7700
1. INNER TUBE ASSY	110173	111086	111087	111086	111089	111090	111091	111089
2. PISTON INNER	213233	214290	214291	214290	214290	214290	214291	214290
3. BALL 3/8 DIA.	400013	400013	400013	400013	400013	400013	400013	400013
4. O-RING 7/16ID X.070	401017	401017	401017	401017	401017	401017	401017	401017
5. BY PASS PLUG	400978	400978	400978	400978	400978	400978	400978	400978
6. BY PASS SHAFT	401338	401338	401338	401338	401338	401338	401338	401338
7. PISTON RING 2 1/4	401516	---	---	---	---	---	---	---
PISTON RING 3 OD	401556	401556	---	401556	401556	401556	---	401556
8. POLYSEAL 2"	401460	---	---	---	---	---	---	---
POLYSEAL 2 3/4ID X 3/16	401461	401461	---	401461	401461	401461	---	401461
9. HEAD 2 3/4 OD	213316	---	---	---	---	---	---	---
HEAD 3 1/2 OD	213317	213317	---	213317	213317	213317	---	213317
10. O-RING 2 1/8	400955	---	---	---	---	---	---	---
O-RING 2 7/8 ID X .070	400956	400956	---	400956	400956	400956	---	400956
11. TUBE 2 3/4 OD	213407	---	---	---	---	---	---	---
TUBE 3 1/2 OD	---	213404	---	213404	213327	213621	---	213327
12. PISTON 3"	211749	---	---	---	---	---	---	---
PISTON 3 3/4 OD	---	211750	---	211750	211750	211750	---	211750

DOUBLE ACTING PARTS LIST CONTINUED								
	2200	3300	4400	5500	5550	6600	6660	7700
13. PISTON RING 3 3/4 X 3/16	—	401557	401557	401557	401557	401557	401557	401557
14. POLYSEAL 3 1/2ID X 3/16	—	401462	401462	401462	401462	401462	401462	401462
15. HEAD 4 1/4 OD	—	213318	213318	213318	213318	213318	213318	213318
16. O-RING 3 1/2ID X .070	—	400957	400957	400957	400957	400957	400957	400957
17. TUBE 4 1/4 OD	—	—	213405	213405	—	213622	213625	213328
18. PISTON 4 1/2 OD	—	—	211751	211751	—	211751	211751	211751
19. O-RING 4 1/2ID X 1/4	—	—	401558	401558	—	401558	401558	401558
20. POLYSEAL 4 1/4ID X 3/16	—	—	401463	401463	—	401463	401463	401463
21. HEAD 5" OD	—	—	213319	213319	—	213319	213319	213319
22. O-RING 4 1/4ID X .070	—	—	400958	400958	—	400958	400958	400958
23. OUTER TUBE ASSY	110019	111079	111080	111080	111082	111083	111084	111085
24. PIPE PLUG	400428	400428	400428	400428	400428	400428	400428	400428

COBRA HYDRAULICS

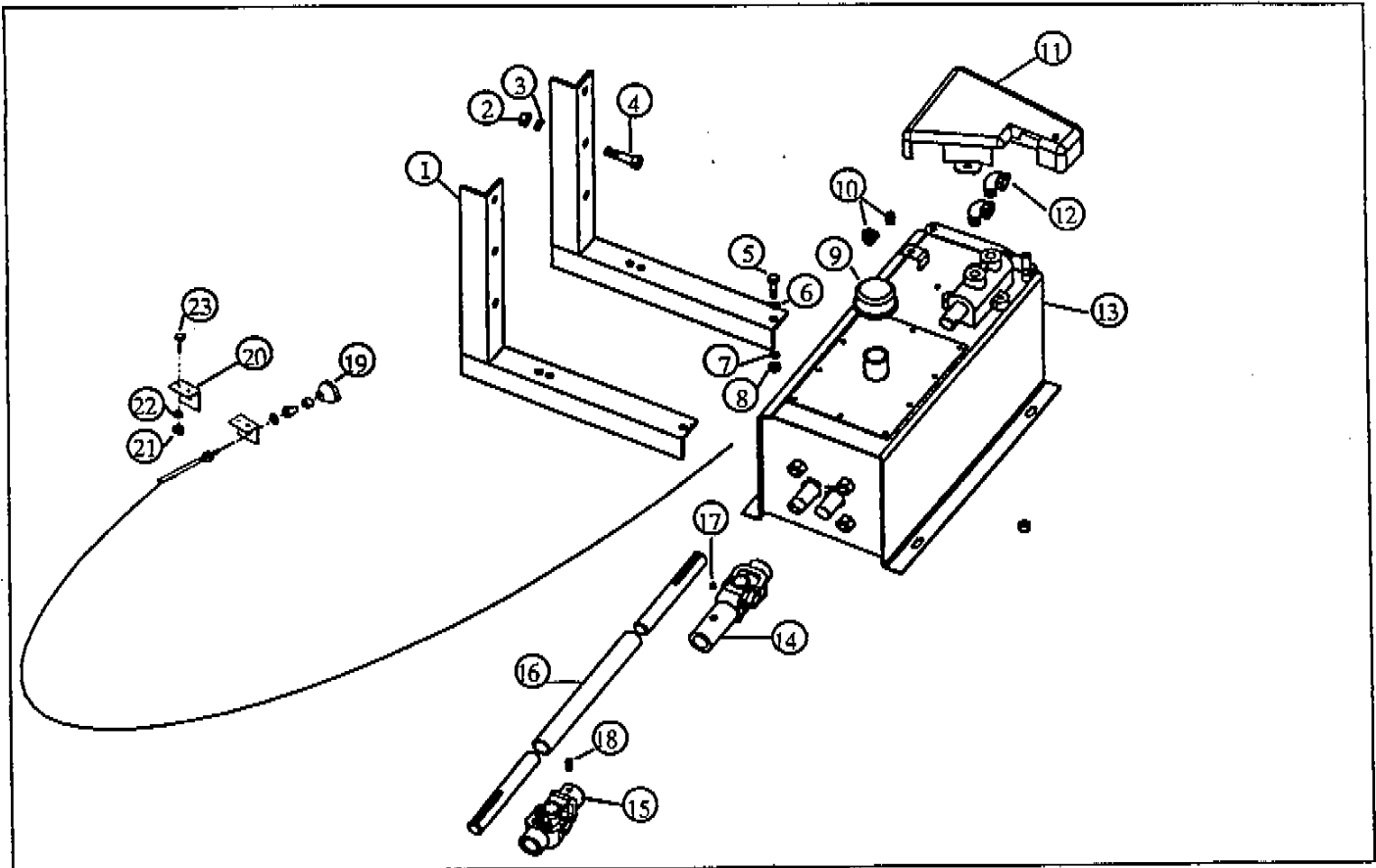

COBRA HYDRAULIC PARTS LIST

ITEM	PART NO.	DESCRIPTION	QTY
1.	100511	Pump Angle	2
2.	400182	Hex Nut 1/2-13	4
3.	400161	Lock Washer 1/2	4
4.	400104	Cap screw 1/2 x 1 3/4	4
5.	400121	Cap Screw 3/8 x 1	4
6.	400164	Flat Washer 3/8	4
7.	400162	Lock Washer 3/8	4
8.	400183	Hex Nut 3/8-16	4
9.	400764	Wms Breather Cap	1
10.	400741	Control Cable Clamp	1
11.	400807	Pump Valve Shield	1
12.	400412	Pipe Elbow 3/8 Street	1
13.	SA	DA Wms Pump	
		401661 1100-4 4 GPM, 15 Qt.	1
		401661 1500-4 4 GPM, 15 Qt.	1
		401662 1500-8 8 GPM, 21 Qt.	1
		401662 1900-8 8 GPM, 21 Qt.	1
		400324 2200 8 GPM, 27 Qt.	1
	401396	400324 3300 8 GPM, 27 Qt.	1
	401395	400317 4400 8 GPM, 27 Qt.	1
	401397	401548 5500 12 GPM, 40 Qt.	1
	401396	400324 5550 8 GPM, 27 Qt.	1
	401397	401548 6600 12 GPM, 40 Qt.	1
	401397	401548 6660 12 GPM, 40 Qt.	1
	401397	401548 7700 12 GPM, 40 Qt.	1
14.	400583	Slip Joint -Long	1
15.	400578	U-Joint Std.	1
16.	200885	Driveshaft 7/8 Sq. x 48"	1
17.	400103	Grease Zerk 1/8	1
18.	400102	Set Screw 3/8 x 1/2	3
19.	400025	Control Cable 15'	1
20.	201391	Control Cable Bracket-Dash	2
21.	400101	Cap Screw 1/4 x 3/4	4
22.	400163	Lock Washers 1/4	4
23.	400184	Hex Nut 1/4-20	4

SPECIALLY DESIGNED – WITH QUALITY IN MIND

WARRANTY

- Crysteel Manufacturing, Inc. warrants its products for a period of one year from date of purchase.
- The warranty provides that our products must perform satisfactorily or we will repair, replace or refund the purchase price at the option of the purchaser. Hydraulic pumps, valves, hoses and other purchased parts are covered by the warranties of their respective manufacturers.
- Any parts returned to Crysteel Manufacturing, Inc. shall be shipped prepaid, and will be returned F.O.B. Lake Crystal, Minnesota.
- We will not assume responsibility for shipping, labor or travel expenses.
- The warranty is void if the product has been obviously abused, or subjected to other than normal usage.
- We reserve the right to make improvements without notice or obligation regarding models previously sold.

! CAUTION !

- **BODY MUST BE BRACED BEFORE SERVICING HOIST OR WORKING IN AREA WITH BODY IN RAISED POSITION**
- **LUBRICATE HOIST GREASE FITTINGS OFTEN – AT LEAST EACH TIME TRUCK IS SERVICED**
- **TRUCK MUST BE LEVEL FOR DUMPING**
- **DO NOT OVERLOAD**

CRYSTEEL MFG. INC.

CRYSTEEL MANUFACTURING, INC.

HIGHWAY 60 EAST • LAKE CRYSTAL, MN 56055

401509 091490