

OWNERS  
MANUAL

**CRYSTEEL'S**

**LO-BOY**

**400 & 500**

**TRUCK HOIST**

MOUNTING AND OPERATING INSTRUCTIONS



HIGHWAY 60 EAST  
P.O. BOX 178  
LAKE CRYSTAL  
MINNESOTA 56055-0178  
TELEPHONE 507-726-2728  
OUT OF MN 800-533-0494

**DATE PURCHASED** \_\_\_\_\_  
**HOIST SERIAL NUMBER** \_\_\_\_\_  
**CYLINDER SERIAL NUMBER** \_\_\_\_\_  
**PUMP SERIAL NUMBER** \_\_\_\_\_  
**DEALER** \_\_\_\_\_  
**ADDRESS** \_\_\_\_\_  
**PHONE** \_\_\_\_\_

**OPERATION AND USE**

1. Engage PTO from cab and adjust engine speed to fast idle.
2. If the hydraulic hose connections are correct, the hoist should raise when the hoist control knob is pulled all the way out, hold when the knob is centered, and lower when the knob is pushed all the way in.
3. Cycle the hoist several times to remove air from the cylinders and hydraulic lines.
4. It is advisable to run the PTO to "power down", or lower, the hoist because this will act as a hydraulic lock to hold the hoist in the lowered position. It is not necessary to do this, however, because the reservoir has sufficient capacity whether or not the hoist is powered down. You will benefit from the advantages of the double acting hoist only if you power it down.
5. To make use of the hydraulic lock feature, place the hoist knob in the center hold position after the hoist is powered down. This places the pressure on the valve, where it belongs, not on the pump.
6. **DO NOT LEAVE THE PTO IN GEAR WHILE TRANSPORTING. THIS WILL CAUSE SEVERE DAMAGE TO THE HYDRAULIC PUMP AND/OR DRIVELINE.**
7. The hydraulic system should be drained, flushed and refilled with proper hydraulic fluid at regular intervals. **CAUTION: NEVER use hydraulic brake fluid in the hydraulic system.**

**SOME DO'S AND DON'T'S FOR SAFETY AND LONG SERVICE**

1. Use the proper hydraulic fluid. **KEEP IT CLEAN.** Remember to change it regularly.
2. Lubricate all grease fittings at regular intervals.
3. **ALWAYS** carefully block up the body, using the body prop, before working under it.
4. Do not "race" the engine when unloading.
5. Do not load the hoist beyond its capacity.
6. **DO NOT** tamper with the hydraulic relief valve. This will void the warranty. It can cause severe damage to the hoist and cylinder.
7. Never leave the PTO in gear while transporting. It will ruin the hydraulic pump.
8. Check all bolts and set screws regularly. Keep them tight.

### FOREWORD

Crysteel's LB400 and LB500 Hoists are designed and intended for use on single-axle trucks with cab-to-axle dimensions of 60 to 132 inches and body lengths of 8 to 14 feet.

This manual contains information necessary for the proper installation and operation of Crysteel's Model LB400 and LB500 Hoists. Study it carefully before attempting to mount or use the hoist. With proper installation and maintenance, the Crysteel Model LB400 or LB500 Hoist will give many years of trouble-free service.

When ordering parts, be sure to give the serial number of the hoist, pump, and cylinder. The serial number of the pump is found on the plate on the front of the pump. The serial number of the cylinder is stamped on the barrel of the cylinder near the base. For future reference, copy these numbers NOW in the space provided on page 1. Order parts by number and description as given in the parts listing in this manual.

**KEEP THIS MANUAL IN A SAFE PLACE FOR FUTURE REFERENCE**

### TABLE OF CONTENTS

- Purchase Record ..... 1
- Operation and Use ..... 1
- Mount Hoist-Subframe Assembly to Truck ..... 3
- Hydraulic Pumps ..... 5
- Mount Standard Pump ..... 5
- Install PTO Drive Shaft ..... 6
- Install Control Cables ..... 6
- Optional Pump With Remote Reservoir Mounting ..... 6
- Optional Electric Pump Mounting ..... 7
- Install Hydraulic Hoses ..... 8
- Add Hydraulic Oil ..... 8
- Power Hoist Down ..... 8
- Install Body on Truck ..... 9
- Install Body Prop Bracket in Body ..... 9
- Install Body Guides ..... 10
- Install Grease Zerks, Lubricate ..... 10
- Install Decals ..... 10
- Decals ..... 11
- Cylinder Illustration and Parts List ..... 12
- Hoist Illustrations ..... 13
- Hoist Parts List ..... 14
- Subframe Illustration and Parts List ..... 15
- Specifications ..... 16
- Warranty ..... Back Page

## MOUNT HOIST-SUBFRAME ASSEMBLY TO TRUCK

Place the hoist-subframe assembly on the truck frame. (See Fig. 1) Set the front of the subframe 3 inches from the back of the cab. The subframe is built for mounting on trucks with an 84" CA dimension. If mounting on a truck with a 60" CA dimension, shorten the subframe 24" at the front end of the subframe. Note: The reservoir mounting bracket will need to be relocated. Mark the front end of the subframe. Note: The reservoir mounting bracket will need to be relocated. Mark the rear of the truck frame even with the back of the subframe. Cut off the truck frame as marked (See Figures 1 and 4.)

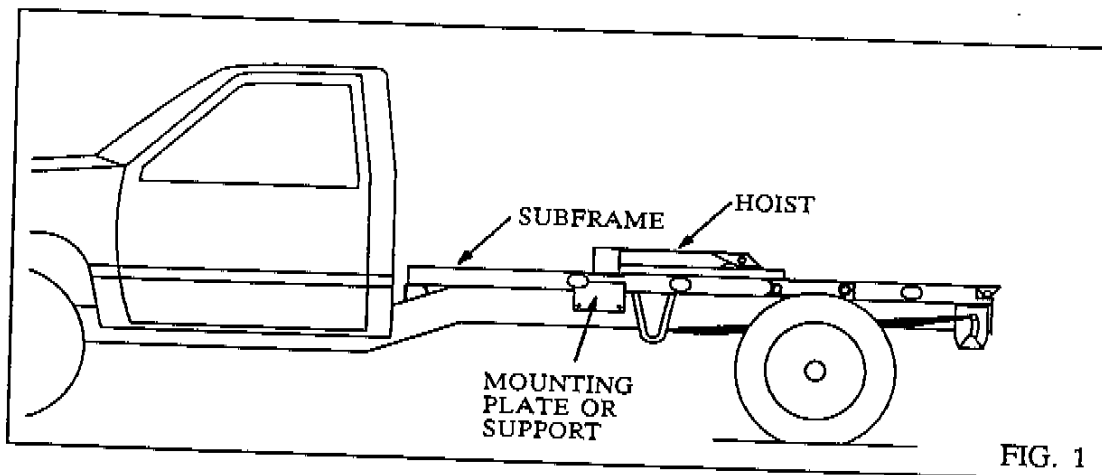
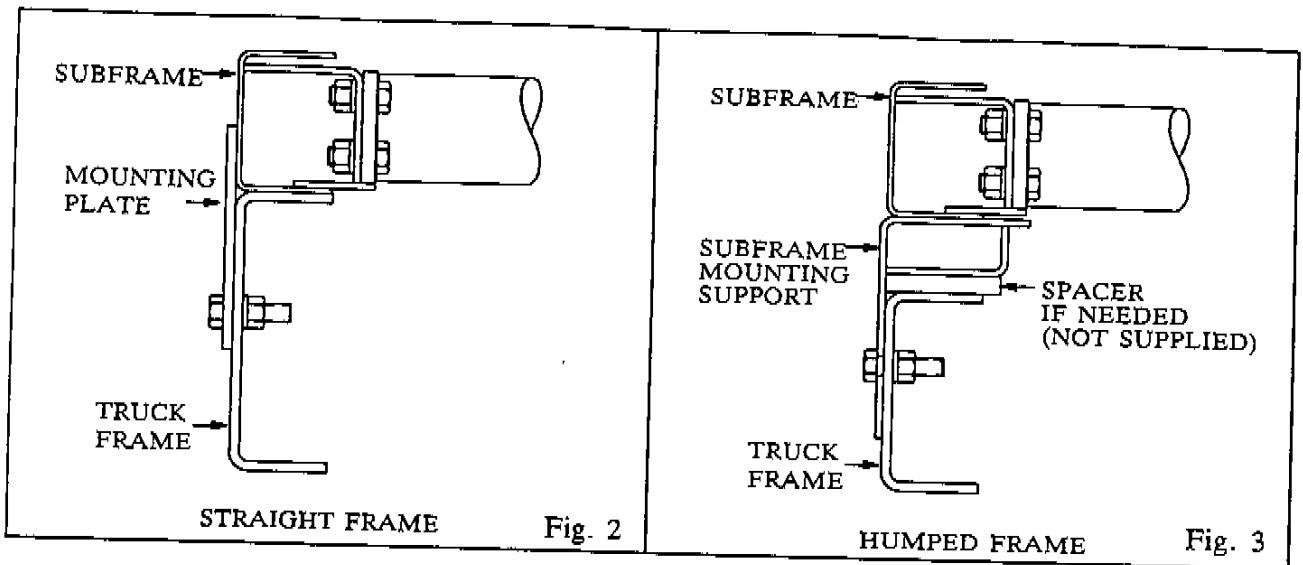

FIG. 1

The hoist is located in the subframe to give a 47° dump angle. If the top flange of the truck frame has rivets, rivet strips (not supplied) can be used to raise the subframe, or holes can be drilled in the bottom flange of the subframe or the subframe can sit directly on the rivet heads. For trucks with a hump in the truck frame over the rear axle, center the subframe mounting support under the lower cross-tube of the hoist (See Fig. 1). Depending on the depth of the hump in the truck frame, it may be necessary to add spacers (not supplied) between the truck frame and the subframe mounting support to raise the mounting support to the height needed so the subframe is level with the truck frame. (See Fig. 3.) Mark the truck frame for drilling using the subframe mounting support as a guide.

For trucks with a straight frame, clamp the flat mounting plates to the outside of the subframe at the lower cross-tube of the hoist. (See Figures 1 and 2.) Mark the truck frame for drilling, using the mounting plates as guides.

**CAUTION: BE CAREFUL OF BRAKELINES, WIRING, ETC. INSIDE THE TRUCK FRAME WHEN DRILLING THE TRUCK FRAME.**



Drill  $17/32$  holes in the truck frame and bolt the subframe mounting supports or plates in place using  $1/2 \times 1 \ 3/4$  cap screws, lock washers and hex nuts. Make sure the subframe is correctly located, centered and square on the truck frame. Clamp the subframe in place and securely weld the subframe to the subframe mounting supports or plates. (See Fig. 1)

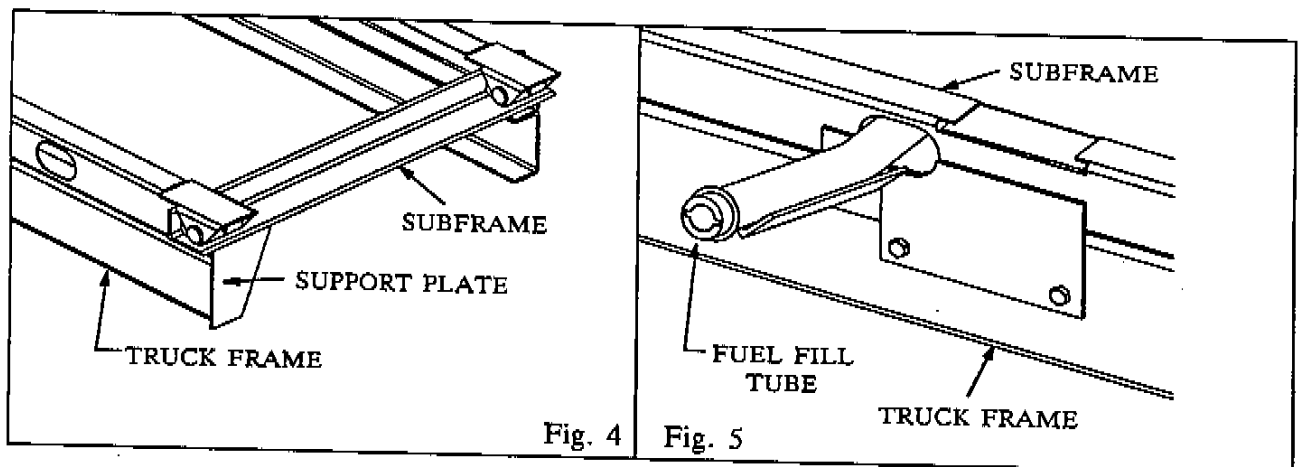

Place the rear hinge support plates against the rear of the truck frame and slide them up to the bottom of the rear hinge frame. (See Fig. 4) Securely weld them to the truck frame and rear hinge. Cut off any excess material below the truck frame.

There are holes in the left (driver's side) subframe rail for routing the fuel tank fill tube to the outside of the truck frame. On Dodge trucks, the fill tube will pass between the subframe and the truck frame. On Chevrolet, GMC and Ford trucks, route the fill tube through one of the holes in the subframe. After the body has been installed, construct a support for the fuel tank fill tube. Construct the support so that it does not interfere with any portion of the body or hoist operation. (See Fig. 5.)

# HYDRAULIC PUMPS

Crysteel offers four different hydraulic pumps for use with the Model LB400 Hoist. Mounting instructions for these pumps can be found on the page shown:

Standard Pump .....	Page 5
Direct Mount Gear Pump with Remote Reservoir .....	Page 6
Remote Mount Gear Pump with Remote Reservoir .....	Page 6
Electric Pump .....	Page 7

## MOUNT STANDARD PUMP

Determine which side of the truck frame to mount the pump (same side as the PTO opening on the transmission). Bolt the mounting angles to the pump using 3/8 x 1 cap screws, flat washers, lock washers and hex nuts. Clamp the pump mounting angles to the truck frame with the pump inside the truck frame a few inches behind the cab. (See Fig. 6). Check that the PTO drive shaft is long enough and does not exceed 15° in angularity. Check for sufficient clearance around the pump. Reposition the pump for the best location. Be sure the PTO shaft and the pump shaft are parallel, because this improves the life expectancy of the U-Joints. In some cases, it may be necessary to rework the exhaust system for sufficient clearance around the pump.

**NOTE: UNDER NO CIRCUMSTANCES SHOULD THE ENGINE EXHAUST BE PERMITTED TO BLOW DIRECTLY ONTO THE PUMP!**

After locating the pump, drill 17/32 holes through the truck frame and bolt in place using 1/2 x 1 3/4 cap screws, lock washers and hex nuts (See caution note on page 3).

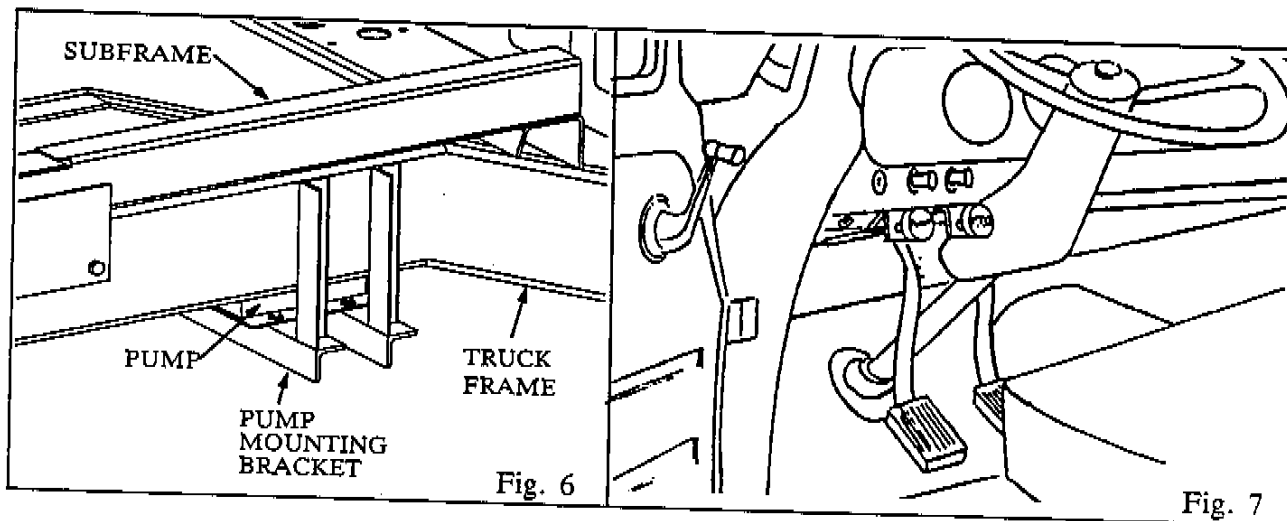

## INSTALL PTO DRIVE SHAFT

Install the long slip U-Joint on the pump shaft and the short U-Joint on the PTO shaft so that the inner edge of the hub of each is flush with the end of the shaft. **DO NOT TIGHTEN THE SETSCREWS!** Measure the distance from the inner edge of the hub of one U-joint to the inner edge of the hub of the other U-joint. This is the length that the drive shaft needs to be. Cut the drive shaft to proper length and deburr. Install the drive shaft and tighten all set screws. Be sure the U-Joints are properly timed with each other because this increases the life expectancy of the U-Joint and gives a smoother, quieter operation. Retighten set screws and secure them with a safety wire.

## INSTALL CONTROL CABLE

Remove the control wire from the control cable housing and oil the inside of the cable housing and reassemble. Attach the control mounting angle at a convenient location under the dash using 1/4 x 3/4 cap screws, lock washers and hex nuts. Insert the control cable through a hole in the firewall, and mount the control cable to the control mounting angle. (See Fig. 7.) Attach other end to the valve control lever on the pump using the parts supplied. Check for proper operation and adjust if necessary. Be sure that there are no sharp bends in the control cable. Keep the control cable away from hot exhaust pipes. Lubricate the control cable regularly.

## OPTIONAL PUMP WITH REMOTE RESERVOIR MOUNTING

Crysteel offers two gear pumps for use on trucks where the standard pump will not fit. The direct mount gear pump mounts directly onto the PTO. The remote mount gear pump can be either PTO or crankshaft driven. Both pumps come with a remote mount reservoir and valve assembly.

The direct mount pump has an SAE "B" 4-bolt flange and a 13 tooth splined shaft that can be bolted directly to a PTO with an SAE "B" flange. Bolt the pump to the PTO and install the pump and PTO on the transmission.

The remote mount gear pump has a 1" round shaft and mounting holes for a pump mounting bracket. The remote mount gear pump can be mounted behind the cab and driven from the PTO. Brackets are included for mounting the pump behind the cab. Use 1/2 x 1 cap screws and lock washers to mount the gear pump to the pump mounting bracket. Read the instructions on page 5 for mounting the standard pump and square drive shaft and mount the remote mount pump and short drive shaft accordingly.

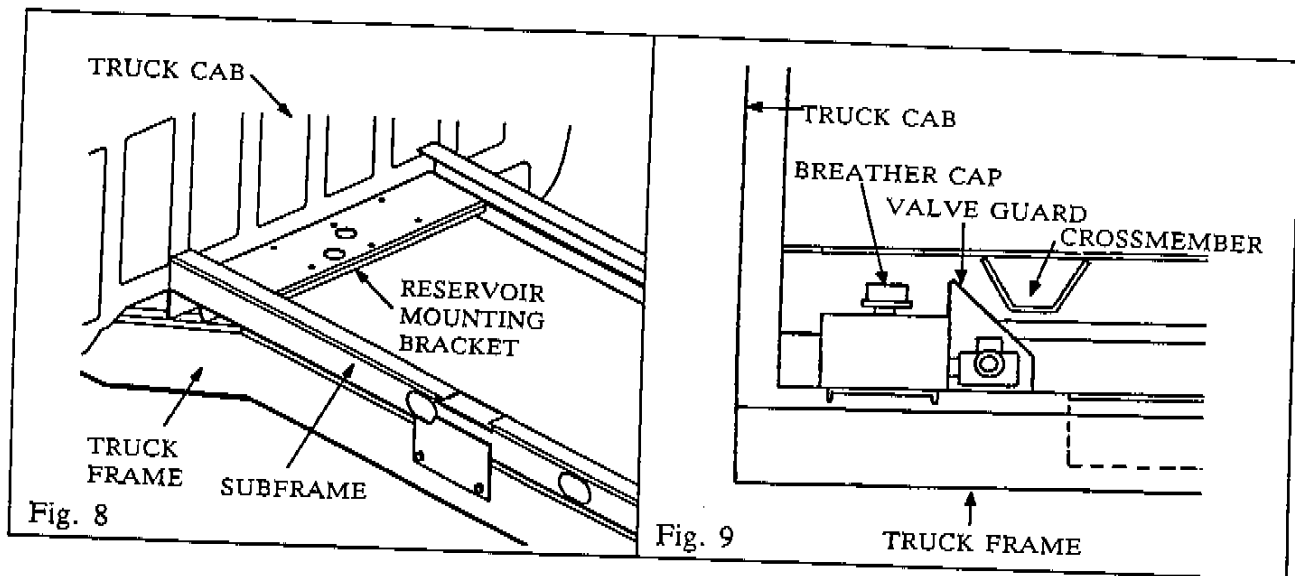

The reservoir mounting bracket is already installed on the subframe near the front. (See Fig. 8) (Note: The optional electric pump can be mounted on this same bracket.) Bolt the reservoir to the mounting bracket using 3/8 x 1 cap screws, lock washers and hex nuts. Connect the hoses and control cable according to the instructions elsewhere in this manual. When mounting the body, make sure that it does not interfere with the reservoir and valve assembly.

Connect a 3/4 inch I.D. suction hose, SAE 100R4, between the pump and the suction port on the reservoir (located on the bottom). Connect a 3/8 inch I.D. pressure hose, SAE R2, between the pump and the pressure port on the valve. This hose must have a minimum pressure rating of 3250 PSI.

### OPTIONAL ELECTRIC PUMP MOUNTING

Use the following instructions for mounting the optional electric pump:

1. Mount the electric pump to the mounting bracket using 3/8 x 1 cap screws, flat washers, lock washers and hex nuts.
2. Install the control cable as directed on page 6.
3. The Monarch electric pump will begin pumping oil when the control cable is pulled or pushed to operate the hoist. Connect the large terminal on the solenoid to the positive terminal on the battery using a No. 0 Gauge or heavier battery cable.
4. **IMPORTANT:** On all electric pump installations, install a heavy duty ground cable from the truck battery directly to the truck frame. The light cable normally used for grounding the engine to the frame is not heavy enough. The recommended battery cable size is No. 0. Never, under any circumstances, use cable lighter than No. 1
5. It is very important that the hose attached to the base end of the cylinder be connected to the valve port pointing toward the reservoir ("B" port) and the hose attached to the rod end of the cylinder be connected to the valve port pointing toward the pump motor. ("A" port) This will give full lifting capacity. If the hoses are reversed, there will be only 14% of full capacity since there is a bypass hole in the motor port of the valve.

## INSTALL HYDRAULIC HOSES

Study the diagram shown in Fig. 10 very carefully and follow it EXACTLY. Remove the port plugs from the cylinder. Connect an 18 inch hose from the base end port of the cylinder to a coupling. Connect a 24 inch hose from the coupling to the raise port on the valve as noted in Fig. 10. NOTE: The swivel ends of the hose should be connected to the cylinder and the valve, not to the couplings. Using the same procedure, connect an 18 inch hose from the rod end port of the cylinder to a coupling. Connect a 48 inch hose from the coupling to the power down port on the valve. Extension hoses, if required, are available from Crysteel. NOTE: IT IS VERY IMPORTANT that the rear port on the valve be connected to the base of the cylinder because the rear port on the valve has full system operating pressure. The front port on the valve has only about half as much pressure.

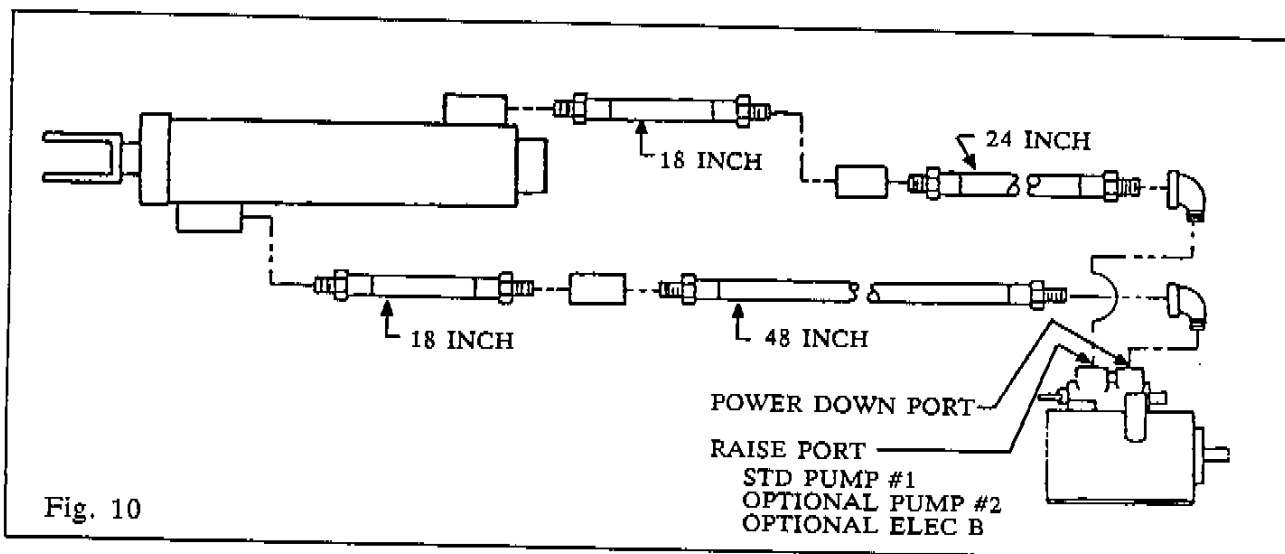

Fig. 10

## ADD HYDRAULIC OIL

Six quarts of hydraulic oil are required to operate the hoist. Use eight quarts in the nine quart reservoir used with the optional gear pump. Use a quality hydraulic fluid of 150 SSU @ 100° F. which contains corrosion and oxidation inhibitors and a foam depressant. This is approximately the equivalent of SAE 10W or lighter weight oil, or use Type A automatic transmission oil for improved performance in cold weather.

**KEEP THE OIL CLEAN. USE CLEAN CONTAINERS, FUNNELS AND OTHER EQUIPMENT!**

## POWER HOIST DOWN

Before mounting the body, the hoist must be completely closed to make certain that the hoist gives full lift height and performance. Make sure the lift plates are straight up and down. Start the truck engine, engage the PTO and power down the hoist to "bottom-out" the hydraulic cylinder and the hoist frame. Place the hoist valve control in the "hold" position. Both the hoist frame and the hydraulic cylinder are now completely closed.

## INSTALL BODY ON TRUCK

The LB400 and LB500 hoist require 6-inch longbeams on the body. Carefully measure the location of the hoist lift plate. Mark this location on the inside of the longbeams and box in the inside of the longbeams. This will provide a flat surface for welding the body and hoist together. Place the body on the truck with 3 inches of clearance behind the cab. Make sure there is sufficient clearance between the body and the reservoir/valve assembly. Relocate the reservoir/valve assembly if necessary. Carefully align the body longbeams to the subframe rails. Securely weld the rear hinge bracket to the longbeams. Securely weld the hoist lift plates to the boxed-in sections of the longbeams.

**DO NOT WORK UNDER A RAISED BODY UNLESS THE BODY IS SECURELY BLOCKED OR PROPPED IN THE RAISED POSITION!**

## INSTALL BODY PROP BRACKET IN BODY

The body prop is designed and intended to support an EMPTY truck body in the raised position. Using the body prop permits service work to be performed safely beneath a raised body. It is mounted on the outside of the subframe on the drivers side.

1. Raise the body to the desired height and brace it securely before beginning installation.
2. Raise the prop arm to a free standing position by allowing the prop arm to rest against the rear flange of the prop pivot.
3. Place the longbeam bracket assy in the body prop saddle. Raise or lower the body as needed to position the bracket on the outside of the longbeam where it will not interfere with the body prop when it is in the stored position and the body is down. Securely weld this bracket assy to the body. (See Fig. 11.)
4. To operate the body prop, raise the body to the desired height, shut off all power, raise the prop arm to a free standing position. Lower the body slowly until the longbeam bracket contacts the prop arm saddle. **DO NOT POWER HOIST DOWN!**
5. To place the body prop in the storage position, raise the body to clear the body prop saddle, lower the body prop to the storage position and lower the body.

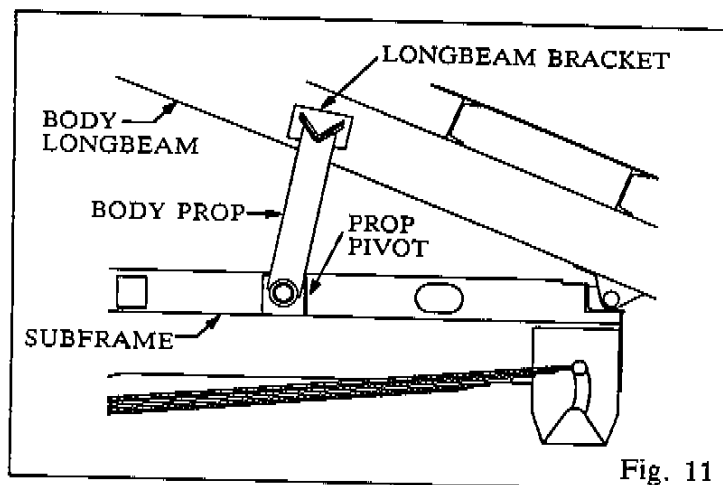

Fig. 11

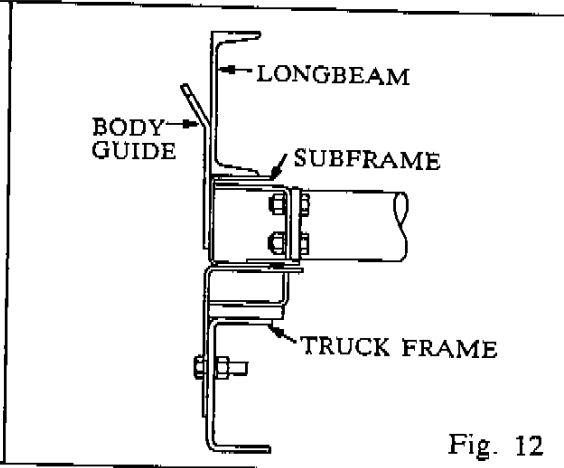

Fig. 12

## INSTALL BODY GUIDES

Two body guides have been included and should be mounted near the front of the subframe. Clamp the body guides to the outside of the subframe as shown in Fig. 12. The body guide should be tight against the outside of the longbeams of the body. Securely weld the body guides to the subframe.

## INSTALL GREASE ZERKS AND LUBRICATE HOIST

Install grease zerks on the hoist and lubricate the hoist in the following locations:

Upper Crosstube .....	2 Fittings
Lower Crosstube .....	2 Fittings
Cylinder Base Pivot .....	1 Fitting
Rear Hinge .....	(already installed) 2 Fittings
U-Joints .....	(2 already installed) 3 Fittings
Body Prop .....	(already installed) 1 Fitting

Lubricate all fittings and the control cable at regular intervals, at least each time the truck chassis is lubricated. There are extremely high forces on the bearings surfaces within the hoist frame. It pays to be generous in lubricating the hoist to insure proper operation and long life.

The center hinge and the cylinder crosshead do not need to be greased. These pivot points are equipped with self lubricating composite bearings that do not need lubrication.

ONE OF THE MOST COMMON REASONS FOR HOIST PROBLEMS IS FAILURE BY THE OPERATOR TO LUBRICATE THE HOIST.

## INSTALL DECALS

After the hoist is installed and the body has been painted, install the decals in the following locations:

1. Decal 400640 Mount in the cab above the valve control.
2. Decal 400719 Mount on the body longbeam near the body prop.
3. Decal 400661 Mount on the body prop arm.
4. Decal 401576 Mount on the outside of the body longbeams near the front of the body (one on each side).
5. Decal 400643 Mount on the body longbeam on the drivers side.
6. Decal 401577 Mount in the cab in a prominent location.
7. Decal 400642 Mount in the cab in a prominent location.

See the illustrations on the following page for decal identification.

**! OPERATION OF BODY PROP !**

1. Raise body to full height and shut off all power.
2. Raise prop to upright position.
3. Lower body slowly until body bracket contacts prop.
4. **DO NOT POWER HOIST DOWN.**

400719

**! DANGER !**

- DO NOT GO UNDER RAISED BODY IT MAY DROP AND KILL YOU
- OPERATE HOIST CONTROLS ONLY FROM INSIDE TRUCK CAB



401576

**! CAUTION !**

- BODY MUST BE BRACED BEFORE SERVICING HOIST OR WORKING IN AREA WITH BODY IN RAISED POSITION
- LUBRICATE HOIST GREASE FITTINGS OFTEN - AT LEAST EACH TIME TRUCK IS SERVICED
- TRUCK MUST BE LEVEL FOR DUMPING
- DO NOT OVERLOAD

CRYSTEEL MFG., INC.

400643

**! DANGER !**

- DO NOT GO UNDER RAISED BODY IT MAY DROP AND KILL YOU
- OPERATE HOIST CONTROLS ONLY FROM INSIDE TRUCK CAB



401577

**! CAUTION !**

- BODY MUST BE BRACED BEFORE SERVICING HOIST OR WORKING IN AREA WITH BODY IN RAISED POSITION
- LUBRICATE HOIST GREASE FITTINGS OFTEN - AT LEAST EACH TIME TRUCK IS SERVICED
- TRUCK MUST BE LEVEL FOR DUMPING
- DO NOT OVERLOAD

CRYSTEEL MFG., INC.

400642

**DOUBLE ACTING VALVE**  
**OUT - RAISE; CENTER - HOLD; IN - LOWER**  
**TO USE HYDRAULIC LOCK-DOWN**

CONTINUE POWER DOWN UNTIL RELIEF VALVE BY-PASSES; THEN SET IN "HOLD" POSITION.

400640

**! CAUTION !**

**UNLOAD BODY BEFORE USING BODY PROP.**

400661

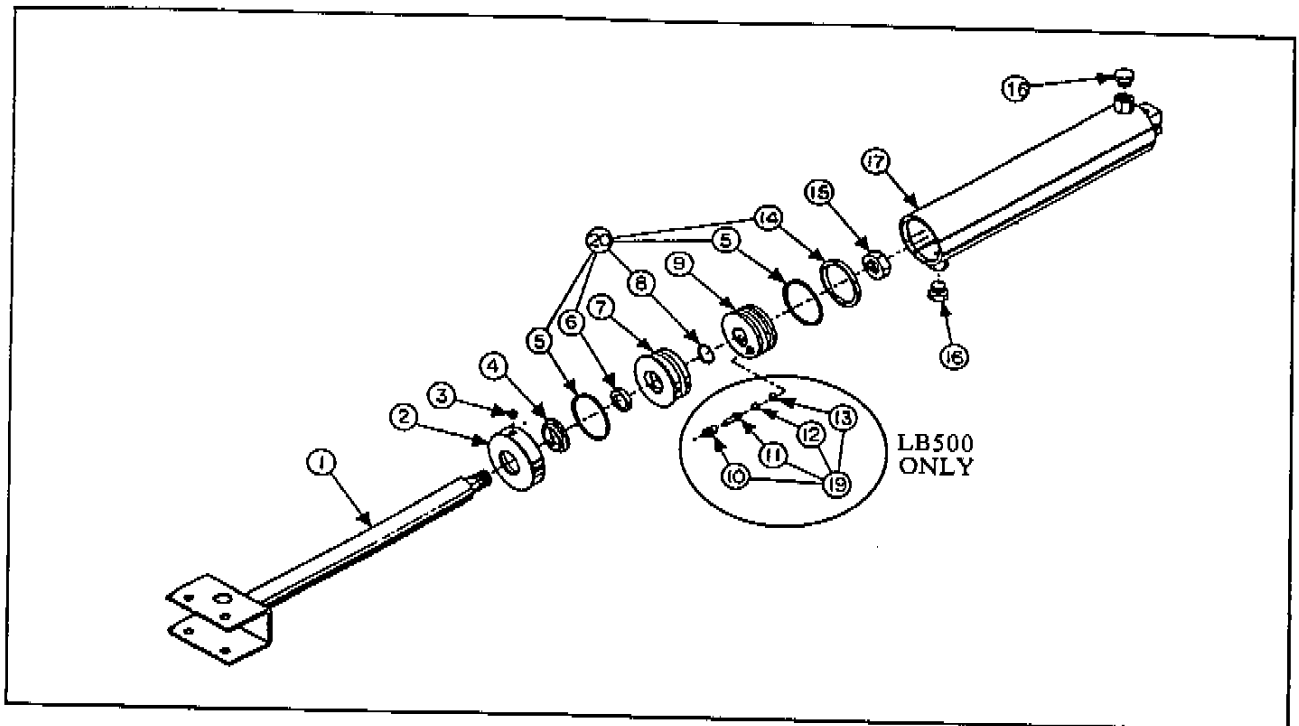

CYLINDER DESCRIPTION LIST LB400 & LB500

KEY	PART NO.		DESCRIPTION	QUANTITY
	LB400	LB500		
1.	105540	110306	Shaft Assembly	1
2.	105541	104293	Cap Assembly	1
3.	400149	400149	Set Screw, Nylon Tip 1/4 x 3/16	1
4.	401133	400913	Wiper Seal	1
5.	400263	400254	O-Ring*	2
6.	401132	400253	Poly Seal*	1
7.	206279	202469	Head	1
8.	401131	400255	O-Ring*	1
9.	206755	202461	Piston	1
10.	NONE	400978	Valve Plug+	1
11.	NONE	400979	Valve Plug+	1
12.	NONE	400013	Steel Ball+	1
13.	NONE	401017	O-Ring 1/16 x 7/16	1
14.	400262	400252	Poly Seal*	1
15.	NONE	401370	Hex Jam Nut 1 1/2-12 Grade 8	1
16.	400422	400422	Plug	2
17.	105539	110305	Cylinder Tube Assembly	1
19.	NONE	105185	Bypass Valve Kit (includes items with+)	1
20.	107958	107960	Seal Kit (includes items with *)	1
21.	105528	110304	Complete Cylinder	1

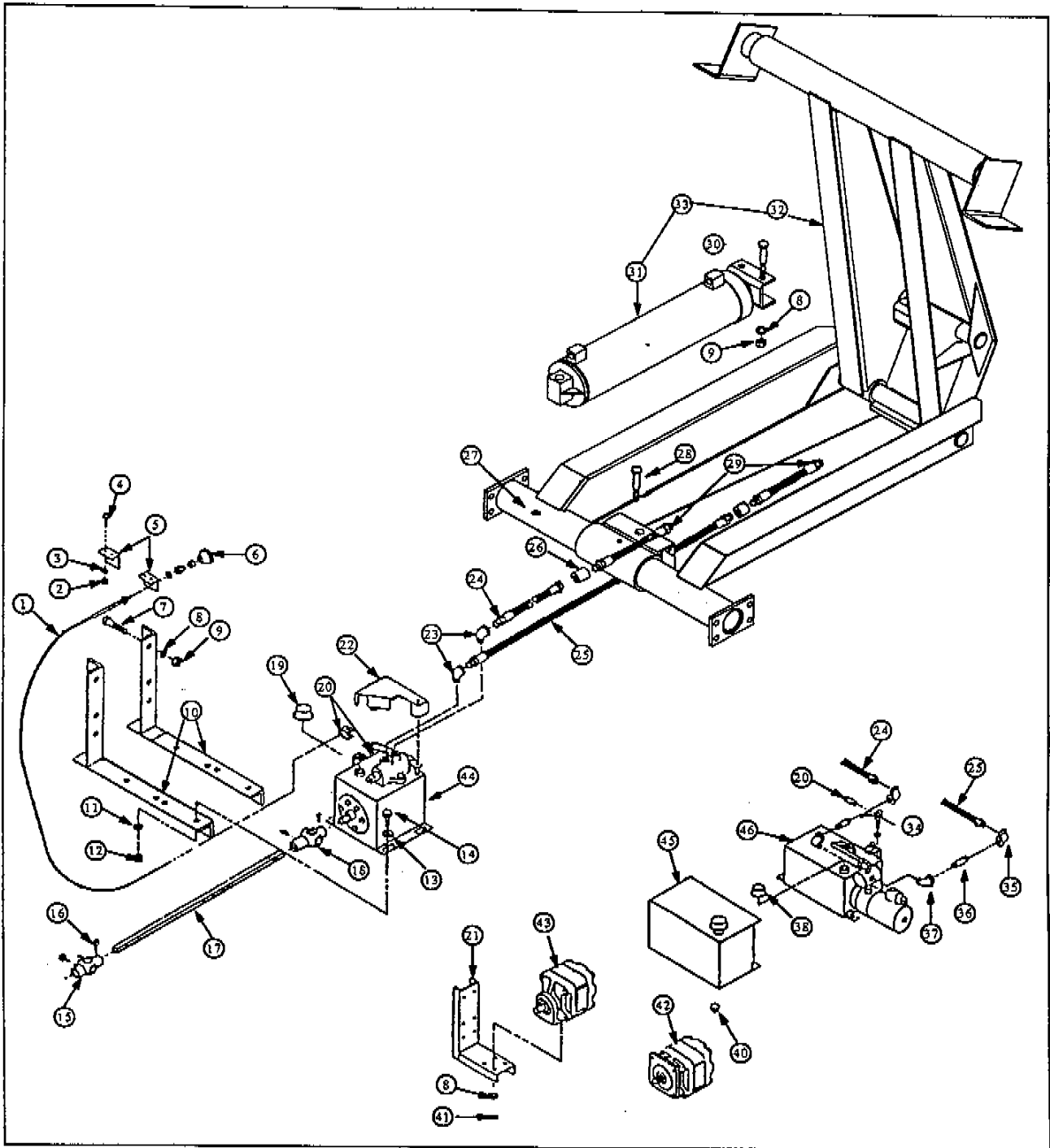

KEY NO	PART NUMBER	DESCRIPTION	QUANTITY
1.	400025	Control Cable, 15'	1
2.	400184	Hex Nut, 1/4-20	4
3.	400163	Lock Washer, 1/4	4
4.	400101	Hex Cap Screw, 1/4-20 x 2/4	4
5.	201391	Cable Mounting Angle	2
6.	400029	Knob, Red Pump (Service Part for Item 1)	-

KEY NO.	PART NUMBER	DESCRIPTION	QUANTITY
7.	400104	Hex Cap Screw, 1/2-13 x 1 3/4	4
8.	400161	Lock Washer, 1/2	6
9.	400182	Hex Nut, 1/2-13	6
10.	100174	Pump Mounting Angle	2
11.	400162	Lock Washer, 3/8	4
12.	400183	Hex Nut, 3/8-16 x 1	4
13.	400164	Flat Washer, 3/8	4
14.	400121	Hex Cap Screw, 3/8-16 x 1	4
15.	400578	U-Joint	1
16.	400102	Set Screw, Square Head 3/8-16 x 1/2	3
17.	200885	Driveshaft, Square 48"	1
	200886	Driveshaft, Square 16"	1
18.	400583	U-Joint, Slip	1
19.	400764	Breather Cap (Service Part for Items 44 and 55)	
20.	400741	Cable Clamp (Service Part for Item 19)	
21.	103691	Pump Mounting Bracket Assy	1
22.	400807	Valve Shield (Service Part for Item 44)	
23.	400412	Street Elbow, 3/8 NPT	2
24.	400510	Hose, 3/8 NPT x 24" (2 wire)	1
25.	400514	Hose, 3/8 NPT x 48" (2 wire)	1
26.	400415	Coupling, 3/8 NPT	2
27.	400103	Grease Zerk, Straight	6
28.	401226	Hex Nut 3/4-18 locking	1
	401237	Hex Cap Screw 3/4 x 4	1
29.	400509	Hose, 3/8 NPT x 18" (2 wire)	2
30.	401140	Hex Cap Screw, 12-13 x 3 3/4	2
31.	105528	Cylinder Assembly Only - LB400	1
	110304	Cylinder Assembly Only - LB500	1
32.	105527	Hoist Frame Only - LB400	1
	110458	Hoist Frame Only - LB500	1
33.	105525	Hoist Frame & Cylinder Assembly - LB400	1
	110457	Hoist Frame & Cylinder Assembly - LB500	1
34.	400145	Eye Bolt	1
35.	400421	Reducing Elbow, 1/4 NPT x 3/8 NPT	2
36.	400420	Nipple, 1/4 NPT x 1 1/2	2
37.	400423	Street Elbow, 1/4 NPT	2
38.	400776	Breather Cap (Service part for Item 46)	
40.	400405	Drain Plug, 3/4 NPT Magnetic	1
41.	400141	Hex Cap Screw, 1/2-13 x 1	1
42.	400394	Direct Mount Gear Pump, 6 GPM	1
43.	400397	Remote Mount Gear Pump, 6 GPM	1
44.	400330	Pump, Standard PTO	1
45.	105850	Reservoir Assembly, 9 Qt.	1
46.	401013	Electric Pump (Optional)	1

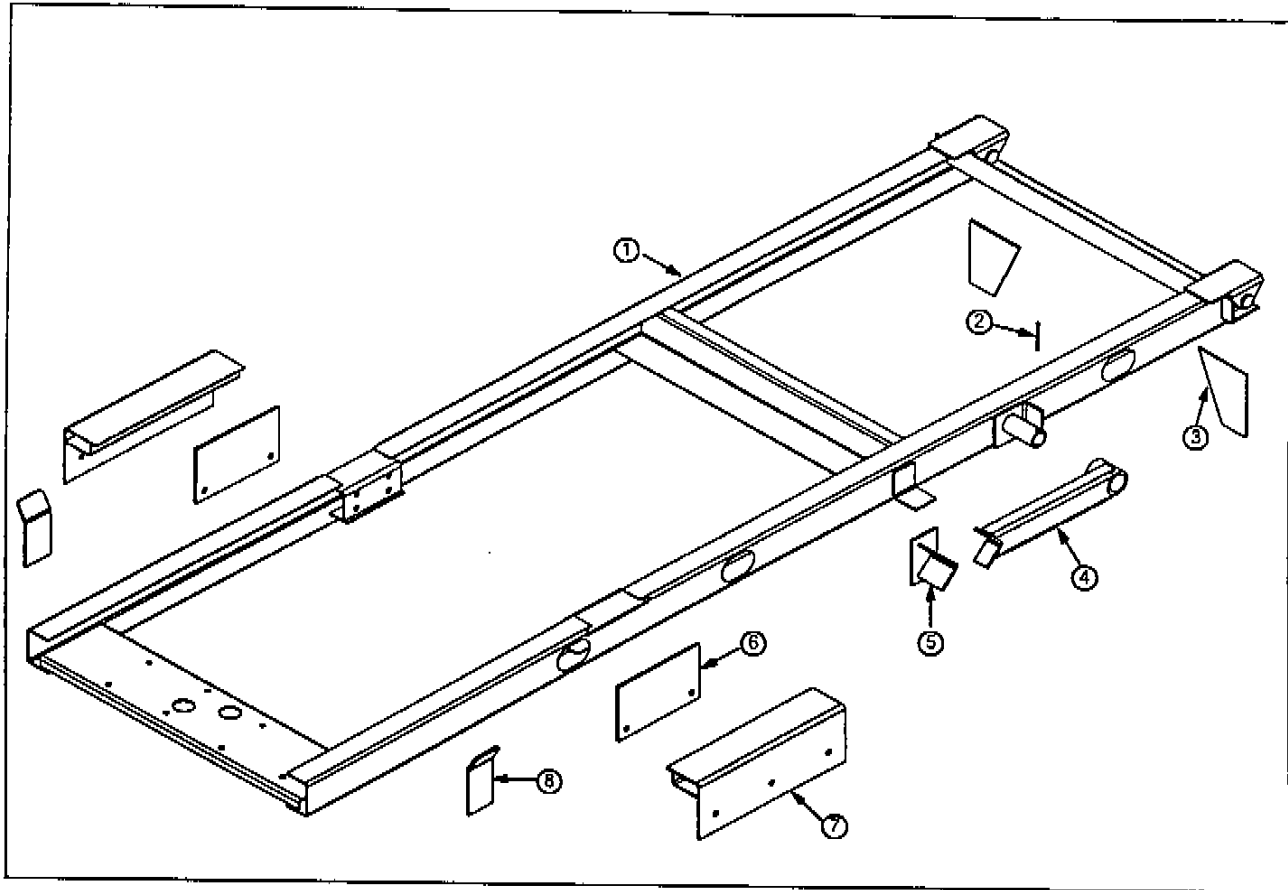

## MODEL LB400 &amp; LB500 SUBFRAME

KEY NO.	PART NUMBER	DESCRIPTION	QTY
1.	109581	Subframe Assy	1
2.	400220	Roll Pin 1/4 x 3	1
3.	206768	Rear Hinge Support	2
4.	110377	Body Prop Arm	1
5.	101221	Body Prop Bracket	1
6.	212916	Mounting Plate (for straight frames)	2
7.	101263	Subframe Mount Angle (for humped frames)	2
8.	214749	Guide	2

**SPECIFICATIONS**  
**LB400 and LB500 LOAD CAPACITIES IN TONS**

BODY LENGTH	8'	9'	10'	12'	14'
Rear Overhang	6	6 18	6 18 30	6 18 30	6 18 30
Hoist Model LB400	7.2	6.3 8.4	5.6 7.2 10.1	N/R 5.6 7.2	N/R N/R N/R
Hoist Model LB500	11.3	9.9 13.2	8.8 11.3 15.9	7.8 8.8 11.3	6.1 7.2 8.8
Cab to Axle	60	72 60	84 72 60	108 96 84	132 120 108

N/R = Not Recommended

\*Capacities at 45°, water level load, includes body weight

CAUTION: The combined weights of truck, body, hoist and load must not exceed the Gross Vehicle Weight rating of the truck.

NTEA Class	Hoist Model	Cylinder Bore-Stroke Shaft	Operating Pressure PSI	Power Down PSI	Mounting Height	Minimum Longbeam Height	Subframe Height	Approx. Weight Pounds	Body Length Feet
B/10	LB400	4"-15 1/4"-1 1/2"	3500	800	9"	5 1/4"	3 3/4"	425	8 to 12
C/20	LB500	5"-15 1/4"-2"	3500	800	9 1/2"	5 3/4"	3 3/4"	460	8 to 14

**NOTES**

*SPECIALLY DESIGNED – WITH QUALITY IN MIND***WARRANTY**

- Crysteel Manufacturing, Inc. warrants its products for a period of one year from date of purchase.
- The warranty provides that our products must perform satisfactorily or we will repair, replace or refund the purchase price at the option of the purchaser. Hydraulic pumps, valves, hoses and other purchased parts are covered by the warranties of their respective manufacturers.
- Any parts returned to Crysteel Manufacturing, Inc. shall be shipped prepaid, and will be returned F.O.B. Lake Crystal, Minnesota.
- We will not assume responsibility for shipping, labor, travel, loss of use or downtime expenses.
- The warranty is void if the product has been obviously abused, or subjected to other than normal usage.
- We reserve the right to make improvements without notice or obligation regarding models previously sold.

**! CAUTION !**

- BODY MUST BE BRACED BEFORE SERVICING HOIST OR WORKING IN AREA WITH BODY IN RAISED POSITION
- LUBRICATE HOIST GREASE FITTINGS OFTEN - AT LEAST EACH TIME TRUCK IS SERVICED
- TRUCK MUST BE LEVEL FOR DUMPING
- DO NOT OVERLOAD

CRYSTEEL MFG, INC.

**CRYSTEEL MANUFACTURING, INC.**  
HIGHWAY 60 EAST P.O. BOX 178 LAKE CRYSTAL, MN 56055-0178