

MARATHON HOIST SPECIFICATIONS					
	M5390	M5399	M53117	M63138	M63153
NTEA Performance Class	70	70	80	120	120
Number of Stages	3	3	3	3	3
Active Stage Sizes (in.)	5,4,3	5,4,3	5,4,3	6,5,4	6,5,4
Total Stroke (in.)	90	99	117	138	153
Cylinder Rated Pressure (PSI)	2500	2500	2500	2500	2500
Cylinder Style	Inverted	Inverted	Inverted	Inverted	Inverted
Std. Pump GMP @1000 RPM	10	15	15	20	20
Std. Reservoir Type	Outside Frame	Outside Frame	Outside Frame	Outside Frame	Outside Frame
Std. Reservoir Size (gal.)	16	16	23	28	28
Recommended Body Length (ft.)	9-10.5	11-11.5	12-13.5	14-15.5	16-16.5
Floor Height (inches)	8	8	8	8	8
Approximate Weight (lbs.)	650	690	780	890	950

MARATHON HOIST LOAD CAPACITY IN TONS*									
Marathon Model	NTEA Class	Body Length (ft.)							
		9	10	11	12	13	14	15	16
M5390	70	36.8	29.8						
M5399	70			27.5					
M53117	80				28.3	24.9			
M63138	120						46.4	42.0	
M63153	120								41.8

Specifications subject to change.

*Capacities based on water-level load, 12" overhang, 50° dump angle, and includes body weight.

CAUTION: The combined weights of truck, body, hoist and load must not exceed the truck's Gross Vehicle Weight rating.



CRYSTEEL MANUFACTURING, INC.
 Lake Crystal, MN • 1-800-533-0494 • FAX 1-507-726-2559
www.crysteel.com • E-mail crysteel@crysteel.com



Sold by:



MARATHON

TELESCOPIC HOIST

CRYSTEEL



- To 47-Ton Capacity.
- Maintenance free cylinder pivots.
- Trunnion mount provides solid stability.
- Hard chrome-plated cylinder surface.

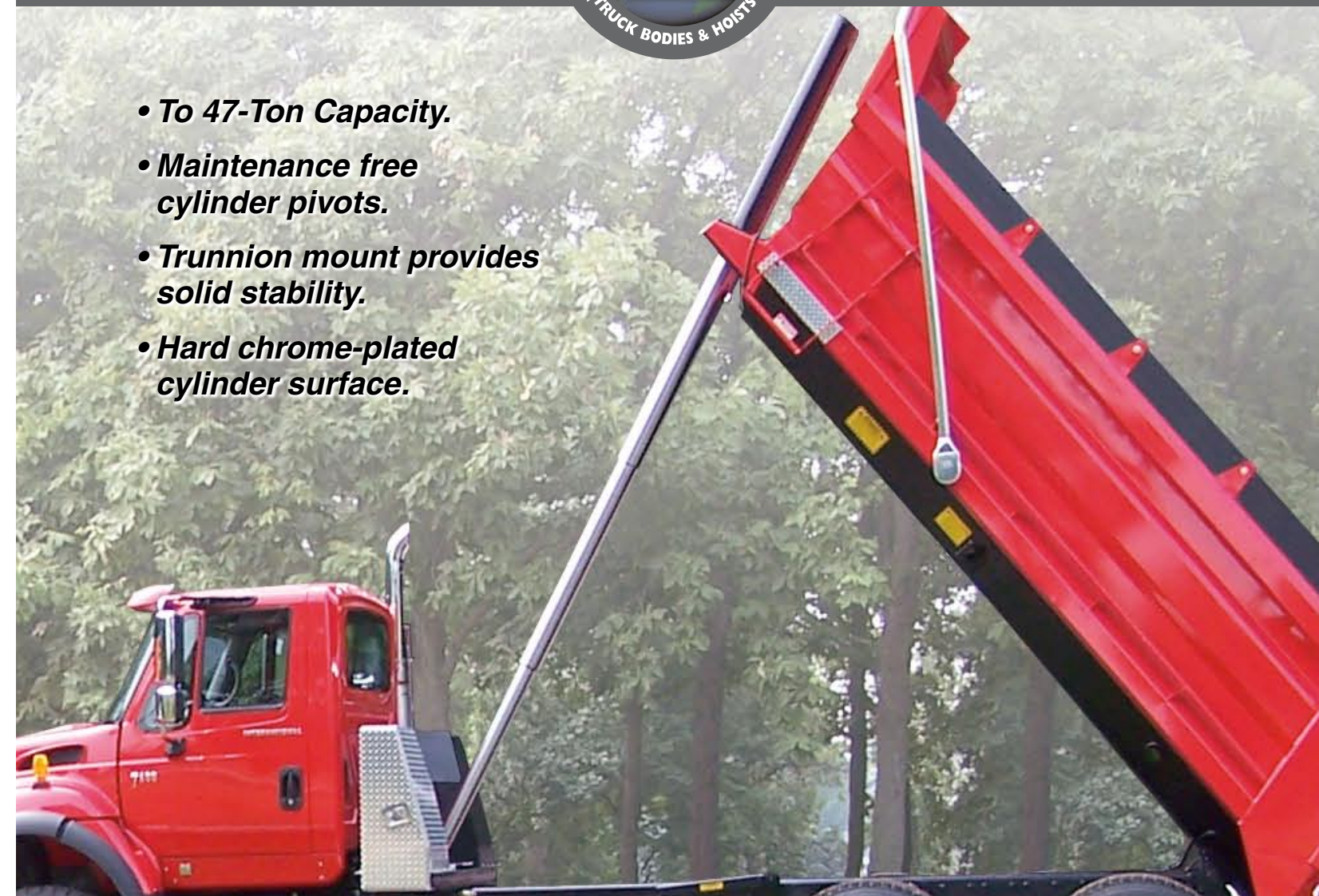

Building the **World's Best** Truck Bodies & Hoists



MARATHON

TELESCOPIC HOIST

Crysteel's Marathon provides Power, Performance, and Endurance

The Marathon Telescopic Hoist offers powerful lifting action while minimizing wasted doghouse space for maximum hauling capacity. Plus, because the Marathon is trunnion-mounted, its stability is unmatched by conventional top pinned telescopic hoists.

Smooth acting final stages finish the job to a minimum 50° dump angle. High pressure maintenance-free twin lip seals never need adjusting. Built-in wipers keep the cylinder surface and seals clean and free of dirt, grit, and dust build-up.

FLOATING CRADLE

Crysteel's Floating Cradle is designed to reduce the bending stress levels between the truck frame and dump body frame that occur when a truck is traveling over uneven terrain.



The Floating Cradle allows the hoist cylinder to pivot up to 2.5 degrees side to side reducing this bending tension. The Crysteel Floating Cradle is specially designed for haulers that move in and out of construction and demolition sites, gravel pits, and mining operations.

EXCELLENT STABILITY

Because the Marathon's body and truck pivots are only a few inches apart, and because the Marathon lifts directly from the body's longitudinals, body twist and leaning are minimized for excellent stability.

COMPREHENSIVE 5-YEAR WARRANTY

Crysteel Manufacturing's Customer Satisfaction Pledge is designed to be the most comprehensive warranty in the truck equipment industry. This pledge covers new products for a period of five (5) years, and is not restricted by vehicle mileage. Complete details available at www.crysteel.com.



Crysteel Marathon's ingenious body mount lifts directly on the longbeams for efficient power delivery and superior stability, throughout the dump cycle.

Quality Performance Features



- Cylinder pivots on maintenance-free, greaseless composite Teflon® bearings.
- Reinforced lower cylinder tube and full-width angle hinge help ensure stability.
- Single-lever locking shifter with sealed cable.
- Reservoirs have sight gauge for easy visual inspection.



Optional Features

- Double-acting cylinders.
- Dual-lever control with sealed cable.
- Air shift control.
- Remote-mount bracket with drive-line kit for pump.
- Remote-mount valve with power beyond capabilities.
- Full-length subframe.
- Removable pin and/or composite bearing rear hinges.
- Remote underbody stabilizer.
- Less hydraulics.
- Return line filter kit.
- "Body up" indicator light kit.



High Performance Crysteel Hydraulics



- Oversized hydraulic hoses keep cycle time fast.
- O-ring ports keep connections leak-free for years of trouble-free service.
- Direct-mount gear pump/valve combination for easy installation.
- Large seals and wipers seal out grit and never need adjusting.
- 2500 psi-rated cylinders match up easily with your central hydraulic system.

Cylinder Retracts

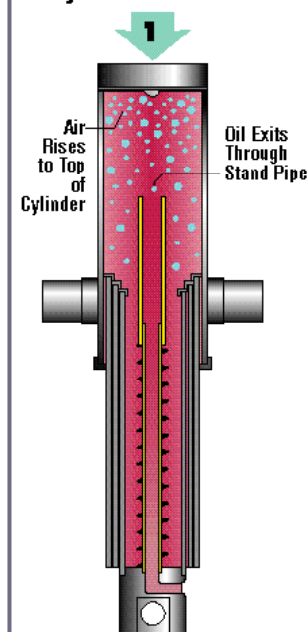

Cylinder Nears End of Stroke

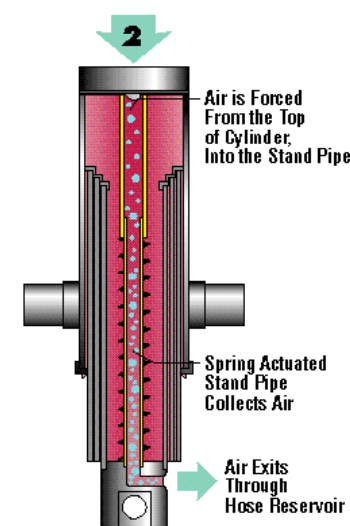

Cylinder Retracted

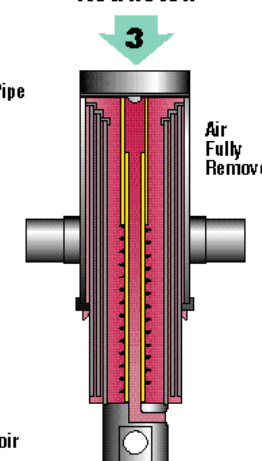

Crysteel Auto-Bleed™ Cylinders

Crysteel's patented AUTO-BLEED™ cylinders eliminate the inconvenience and dangers of manually bleeding air out of your cylinder. The AUTO-BLEED system **automatically** and **effortlessly** removes unwanted air from the hydraulic system safely and cleanly. Marathon hoists with the patented AUTO-BLEED system set a new **standard of excellence** in the truck hoist industry.

Patent Numbers
US 5,390,586
Canada 2,142,374
Mexico 185,833