

# **CRYSTEEL'S**

# **LO-BOY**

# **TRUCK HOIST**

## **OPERATION - INSTALLATION - PARTS**

**USE WITH  
HOISTS WITH  
THIS LABEL**

**NOTICE**

THIS IS A NEW *LO-BOY* MODEL!  
THE MOUNTING DISTANCES HAVE  
CHANGED.

PLEASE REFER TO THE NEW  
INSTALLATION MANUAL,  
P/N 406805, DATED 8/31/2004.

THIS NEW MANUAL IS FOUND IN  
CARTONS WITH A SIMILAR DECAL.

REMOVE THIS DECAL DURING INSTALLATION. P/N 406805



P.O. Box 178  
52182 Ember Road  
Lake Crystal, MN 56055

[www.crysteel.com](http://www.crysteel.com)  
[crysteel@crysteel.com](mailto:crysteel@crysteel.com)  
(507) 726-2728 (800) 533-0494

1902 Route 57 South  
Fulton, NY 13069

**DATE PURCHASED** \_\_\_\_\_  
**HOIST SERIAL NUMBER** \_\_\_\_\_  
**CYLINDER SERIAL NUMBER** \_\_\_\_\_  
**DEALER** \_\_\_\_\_  
**ADDRESS** \_\_\_\_\_  
**PHONE** \_\_\_\_\_

**FOREWORD**

Crysteel's LoBoy hoists have been designed for use on single-axle trucks with cab-to-axle dimensions of 60 to 150 inches for use with bodies of 8 through 18 feet in length and on tandem axle trucks with cab-to-tandem center dimensions of 102 to 180 inches for use with bodies from 14 to 24 feet in length. Bodies normally used with these hoists are grain bodies and platforms. This manual contains the information needed for the proper installation and operation of these hoists.

These instructions are for installing and maintaining all models of LoBoy hoists. With proper installation, use, and regular maintenance, Crysteel's LoBoy truck hoists will give many years of trouble free service.

When ordering parts, be sure to give serial number of hoist and cylinder. The serial number of the hoist is stamped into the hoist frame near the base end of the cylinder. The serial number of the cylinder is stamped on the barrel of the cylinder near the base. For future reference, copy these numbers NOW in the space provided above. Order parts by number and description as given in the parts listing in this manual.

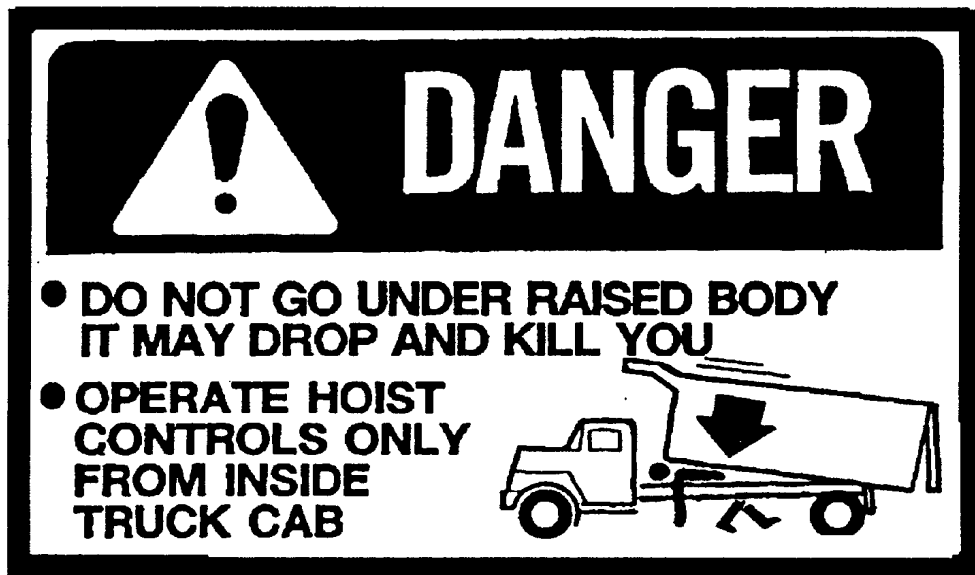

## **OPERATION AND USE**

1. Engage PTO from cab and adjust engine speed to fast idle.
2. The hoist should raise when the hoist control lever is pulled back, hold when the lever is in the center detent, and lower when the lever is pushed forward.
3. To raise the hoist, pull the control lever back. To hold the body in a raised position, place the control lever in its center detent position. To lower the hoist, push the control lever forward.
4. ALWAYS return the hoist control lever to its center detent position after each use.
5. DO NOT LEAVE THE PTO IN GEAR WHILE TRANSPORTING. THIS CAN CAUSE SEVERE DAMAGE TO THE PTO OR HYDRAULIC PUMP.
6. To raise the body prop, raise the body, shut off all power, raise the prop arm to a free standing position. Lower the body slowly until the body prop bracket contacts the prop arm saddle.
7. To lower the body prop, raise the body, lower the prop arm to its storage position. Lower the body.
8. The hydraulic system should be drained, flushed and refilled with proper hydraulic fluid at regular intervals. CAUTION: NEVER use hydraulic BRAKE FLUID in the hydraulic system.

## **SOME DO'S AND DON'TS FOR SAFE AND LONG SERVICE**

1. Use the proper hydraulic fluid. KEEP IT CLEAN. Remember to change it regularly.
2. Lubricate all grease fittings every 100 cycles or every two months. Infrequent or insufficient lubrication will cause hoist failure and possibly injury or death.
3. ALWAYS carefully block up the body, using the body prop, before working under it.
4. Do not "race" the engine when unloading.
5. Do not load the hoist beyond its capacity.
6. DO NOT tamper with the hydraulic relief valve. This will void the warranty. It can cause severe damage to the hoist and cylinder.
7. Never leave the PTO in gear while transporting. It could ruin the hydraulic pump, the PTO or the transmission.
8. Check all bolts and fittings regularly. Keep them tight. See table on page 4 for torque values.
9. Always operate hoist on a firm and level surface.
10. Always make sure area around truck is clear and safe for hoist operation and dumping.

## TABLE OF CONTENTS



Purchase Record	1
Foreword	1
Operation and Use	2
Some Do's and Don't's	2
Table of Contents	3
Installation Instructions	4
General Information	4
Locate and Install Rear Hinge	5
Locate Hoist	6
Mount Hoist Frame	7
Hydraulic Systems	7
Install Gear Pump – B-5 (Bert), C-8 (Charlie) & D-9 (Daniel)	7
Install Gear Pump – D-10 (David), E-15 (Ernie), F-18 (Floyd) & H-25 (Henry)	8
Mount Reservoir/Valve Assembly – B-5 (Bert), C-8 (Charlie) & D-9 (Daniel)	8
Mount Reservoir/Valve Assembly – D-10 (David), E-15 (Ernie), F-18 (Floyd) & H-25 (Henry)	9
Install Hoist Control	10
Install Hoses – B-5 (Bert), C-8 (Charlie) & D-9 (Daniel)	11
Install Hoses – D-10 (David), E-15 (Ernie) & F-18 (Floyd)	12
Install Hoses – H-25 (Henry)	12
Add Hydraulic Oil	13
Electric Power Unit Mounting – General	14
Install Hoses – Single-Acting	15
Install Hoses – Double-Acting	15
Add Automatic Transmission Fluid	16
Mount Body	17
Install Body Guide Plates	17
Install Body Prop	18
Install Grease Zerks & Lubricate	19
Install Decals	20
Parts Lists and Diagrams	21-33
Specifications	34
Capacity Formula	34

# INSTALLATION INSTRUCTIONS

## GENERAL INFORMATION

It is a good idea to look through these installation instructions before beginning to mount the hoist and hydraulic system.

When welding, protect the truck's electrical, air and brake systems by disconnecting, removing or covering. Tighten all nuts and bolts to a consistent level. Use the following table for torque values.

Size	Grade 2 Torque	Grade 5 Torque	Grade 8 Torque
			
1/4-20	3-4 lb-ft	6-7 lb-ft	10-11 lb-ft
1/4-28	4-5 lb-ft	8-9 lb-ft	11-12 lb-ft
5/16-18	8-9 lb-ft	14-15 lb-ft	21-22 lb-ft
5/16-24	9-10 lb-ft	15-16 lb-ft	21-22 lb-ft
3/8-16	17-18 lb-ft	24-26 lb-ft	37-40 lb-ft
3/8-24	19-20 lb-ft	28-30 lb-ft	40-43 lb-ft
1/2-13	38-42 lb-ft	60-65 lb-ft	90-100 lb-ft
1/2-20	43-47 lb-ft	70-75 lb-ft	95-105 lb-ft
5/8-11	75-80 lb-ft	122-130 lb-ft	180-190 lb-ft
5/8-18	85-90 lb-ft	145-150 lb-ft	200-210 lb-ft
3/4-10	132-140 lb-ft	220-230 lb-ft	315-330 lb-ft
3/4-16	152-160 lb-ft	250-260 lb-ft	355-370 lb-ft

## LOCATE AND INSTALL REAR HINGE

On single-axle trucks, the rear hinge must be located as close as possible behind the rear spring hanger. This will be 32 to 36 inches behind the center of the rear axle. On tandem axle trucks the center of the rear hinge should be located 42 to 50 inches behind the center of the rear tandems. Mark the rear of the truck frame for notching as shown in Figure 1. Notch the truck frame as marked. Make sure the rear hinge is square with the truck frame and at the correct height. The top surface of the rear hinge bracket should be flush with the top of the angle mounting brackets of the hoist frame as shown in Figure 1. Securely weld the rear hinge to the truck frame. Cap the ends of the truck frame under the rear hinge. Weld the capping plates to the ends of the truck frame and to the bottom side of the rear hinge angle.

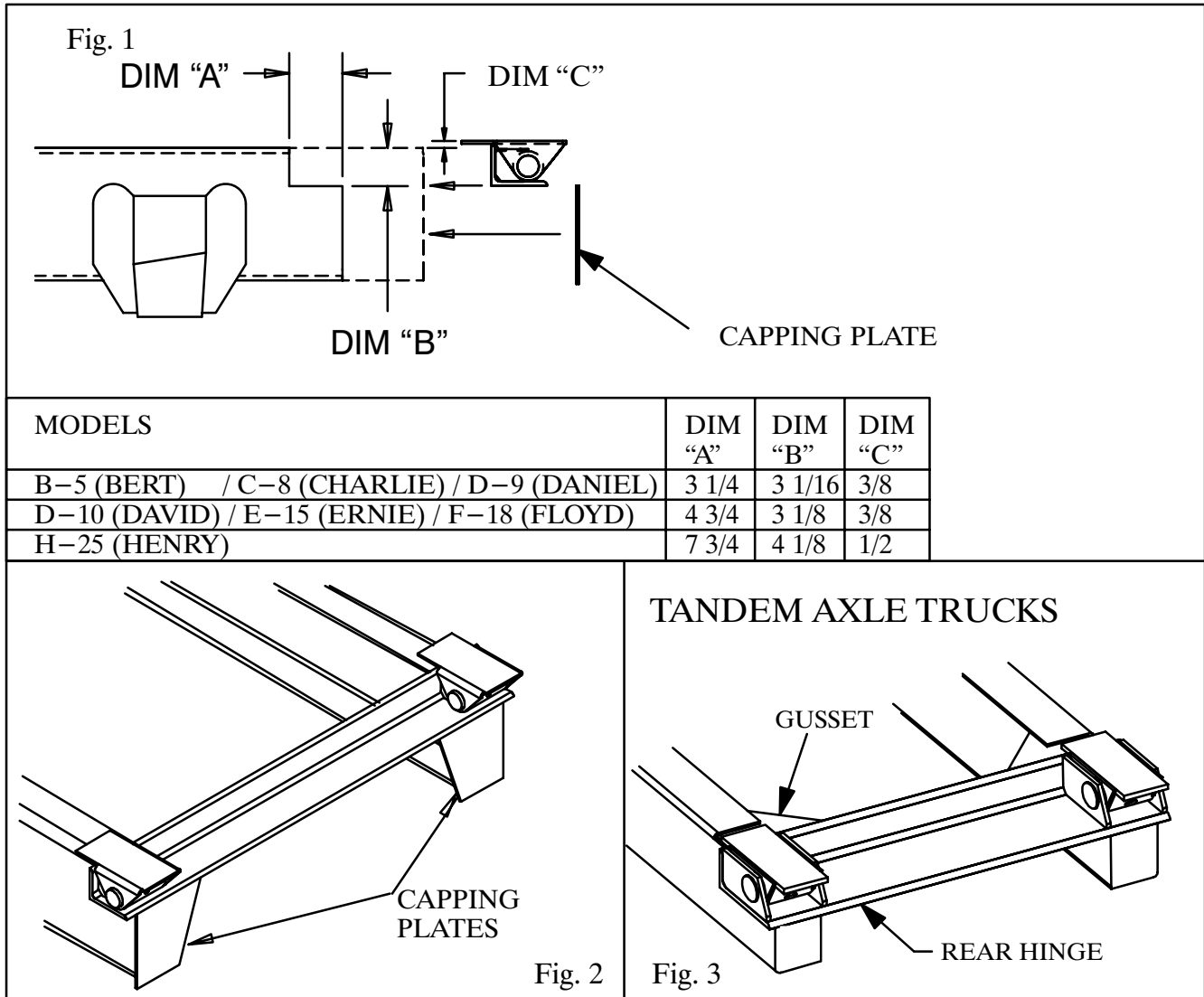

On tandem-axle trucks, place the gussets in the corners formed by the truck frame rail and the rear hinge frame angle. Raise the front end of the gusset so it touches the top flange of the truck frame rail. Be sure that the gusset does not interfere with the rear hinge operation. Securely weld the gussets to the rear hinge, the truck frame rail and the top flange of the truck frame rail.

***WARNING! LOCATING THE REAR HINGE FARTHER BACK THAN RECOMMENDED MAY CAUSE UNDUE STRESS IN THE TRUCK FRAME, AND MAY CAUSE INSTABILITY DURING THE LIFTING CYCLE!***

# LOCATE HOIST

Determine where to mount the hoist on the truck. Please refer to the chart in Fig. 4 for the relationship between dump angle and “D” dimension. Measure forward from the center of the rear hinge pin and mark, on the truck frame, the location of the front crosstube of the hoist frame. Place the hoist on the truck frame and clamp the hoist pivot pads to the truck frame. The back end of the hoist must be supported by a crossmember in the truck frame. The top of this crossmember may be up to 1” below the top of the truck frame. The “CM” dimension shows the location for this crossmember. Make sure the hoist frame is centered on and square with the truck frame.

If desired, the hoist can be turned end for end for a 'Reverse' mount. This does not affect the lifting capacity.

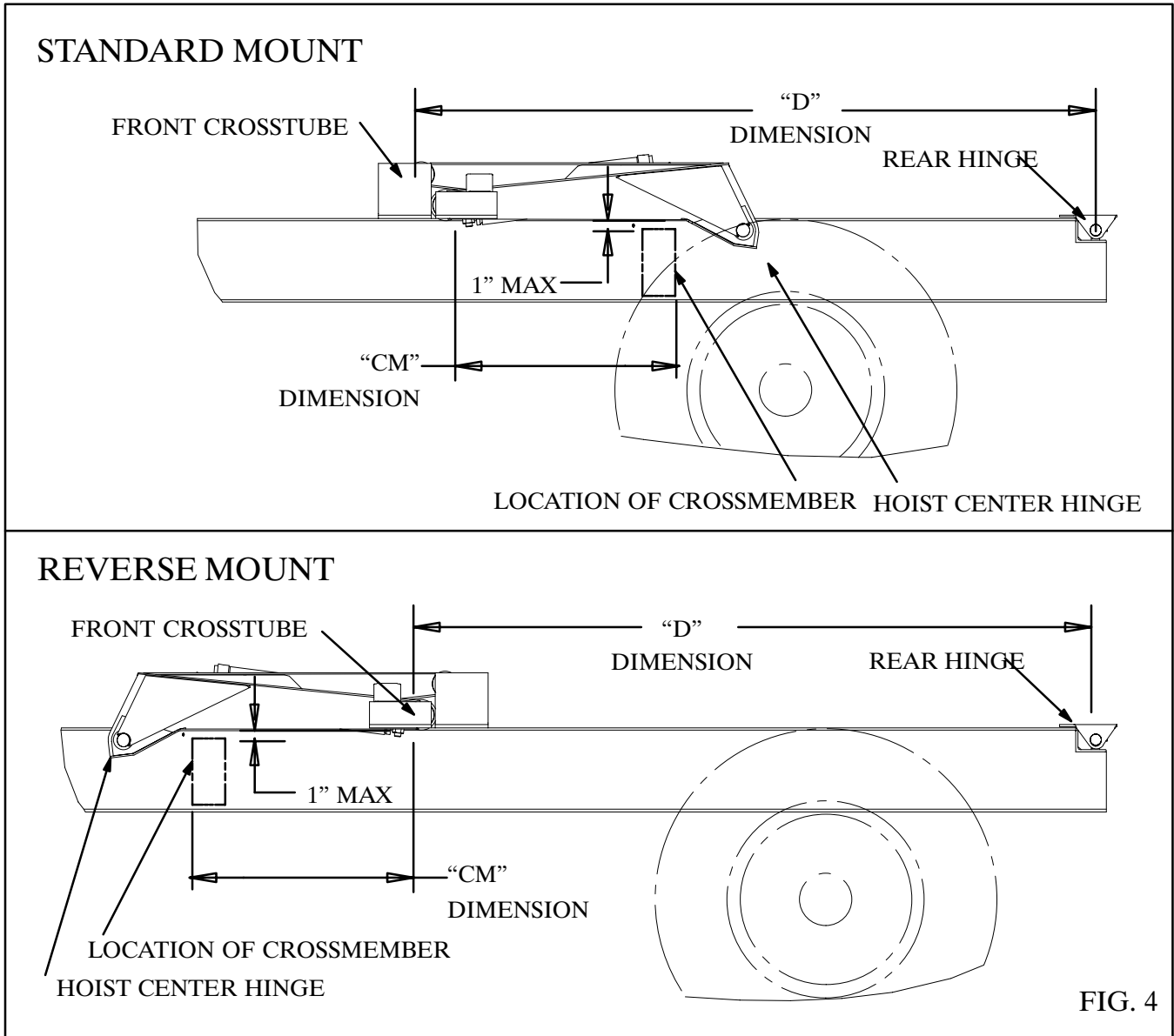
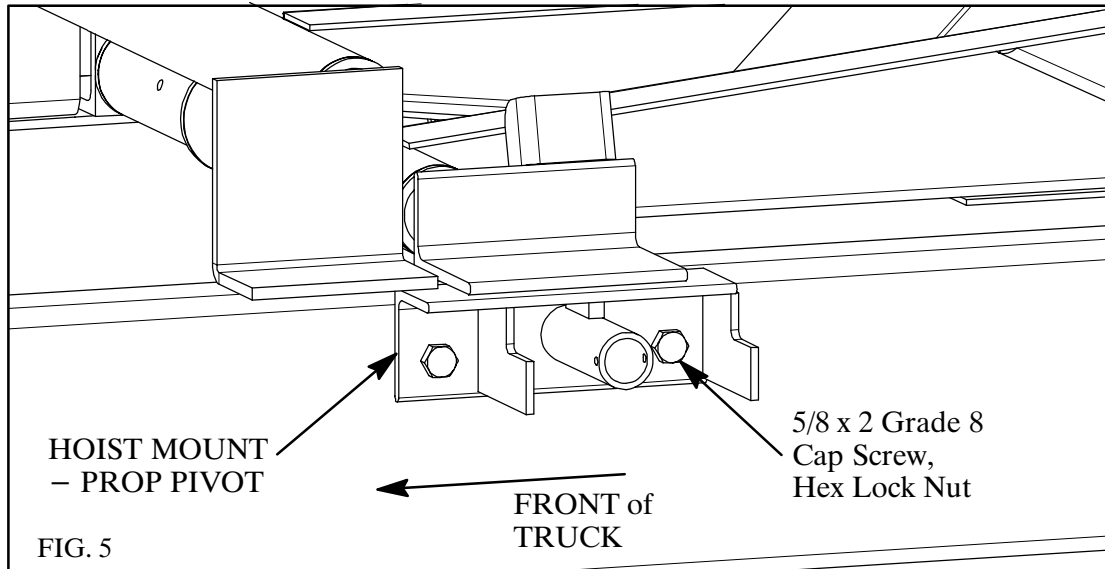

FIG. 4

DIMENSIONS	“D”					“CM”
	DUMP ANGLE	35°	40°	45°	50°	
B-5 (BERT), C-8 (CHARLIE) & D-9 (DANIEL)	97 1/2”	86 3/4”	77 3/4”	70 1/2”	64 3/4”	30”
D-10 (DAVID) & E-15 (ERNIE)	122”	108”	99”	88”	81”	34”
F-18 (FLOYD) & H-25 (HENRY)	169”	149”	133”	120”	111”	43”

## MOUNT HOIST FRAME

The hoist pivot pads must rest flat on the truck frame. If the hoist pivot pads sit on rivet heads in the truck frame, either move the hoist or drill holes in the pivot pads to clear the rivets. On the driver's side, clamp the hoist mount/prop pivot the lower hoist pivot pad and to the outside of the truck frame. On the passenger side, clamp a hoist mounting angle to the lower hoist pivot pad and to the outside of the truck frame. Mark the truck frame for drilling. See Figure 5.



**CAUTION: BE CAREFUL OF BRAKELINES, WIRING, ETC. INSIDE THE TRUCK FRAME WHEN DRILLING THE TRUCK FRAME.**

Drill 21/32 diameter holes in the truck frame using the hoist mounting angles as guides. Bolt the prop pivot and mounting angle to the truck frame using 5/8 x 2 hex bolts and hex lock nuts, tightening to 180 to 190 lb-ft. Securely weld the lower hoist pivot pads to the mounting angles. **DO NOT WELD THE HOIST PIVOT PADS TO THE TRUCK FRAME!** Remove the clamps.

## HYDRAULIC SYSTEMS

Crysteel offers PTO driven, gear pump hydraulic systems for use with all models of LoBoy hoists. Crysteel also offers electric power units, both single- and double-acting, for all models except H-25 (Henry). Mounting instructions can be found on the pages shown:

PTO driven Gear Pump with Remote Reservoir/Valve .....	Page 7
Electric Pumps - General .....	Page 14
Electric Pump - Single-Acting .....	Page 15
Electric Pump - Double-Acting .....	Page 15

## INSTALL GEAR PUMP - B-5 (BERT), C-8 (CHARLIE) & D-9 (DANIEL)

The gear pump for the B-5 (Bert), C-8 (Charlie) and D-9 (Daniel) models has an SAE 'A' mounting configuration, a 9 tooth splined shaft and a two-bolt mounting flange, and is assembled for counter-clockwise rotation. Note: This pump will mount directly to Chelsea's output type 'XE' or Muncie's output type 'R'. Crysteel Manufacturing recommends a PTO ratio of 100-120%. This assures a minimum pump operating speed of 600 RPM. **CHECK THE ROTATION OF THE PTO!** If it is opposite of the engine, then the pump can be used as it is. If the PTO rotation is the same as the engine, then the pump will need to be reversed. (See instructions included with the pump.) Bolt the gear pump to the PTO output flange using 3/8 x 1" cap screws and lock washers.

NOTE: A pump with an SAE 'A' mounting configuration, a two-bolt mounting flange, but with an 11 tooth splined shaft, assembled for counterclockwise rotation, is available for use with PTOs for the Ford TorqShift automatic transmission.

### **INSTALL GEAR PUMP – D-10 (DAVID), E-15 (ERNIE), F-18 (FLOYD) & H-25 (HENRY)**

The gear pump for the D-10 (David), E-15 (Ernie), F-18 (Floyd) and H-25 (Henry) hoists has an SAE 'B' mounting configuration, a 13 tooth splined shaft and a four-bolt mounting flange, and is assembled for rotation in either direction. NOTE: This pump will mount directly to Chelsea's output type 'XK' or Muncie's output type 'D'. Crysteel Manufacturing recommends a PTO ratio of 100-120%. This assures a minimum pump operating speed of 600 RPM. Bolt the gear pump to the PTO output flange using 1/2 x 1 1/4 cap screws and lock washers.

### **MOUNT RESERVOIR/VALVE ASSEMBLY – B-5 (BERT), C-8 (CHARLIE) & D-9 (DANIEL)**

Determine which side of the truck to mount the reservoir/valve assembly. The same side as the PTO opening on the transmission would be ideal. Using 3/8 x 1" cap screws, flat washers and hex lock nuts, bolt the reservoir mounting angles to the reservoir/valve assembly so the exposed end of the valve spool is toward the cab (See Fig. 7). This makes it much easier to connect the valve control cable to the valve. Place this assembly against the outside of the truck frame on the same side as the pump. Mark the truck frame for drilling using the mounting angles as guides. Make sure there is enough clearance for hot exhaust pipes. *THE ENGINE EXHAUST MUST NEVER BLOW DIRECTLY ONTO THE RESERVOIR/VALVE ASSEMBLY.*

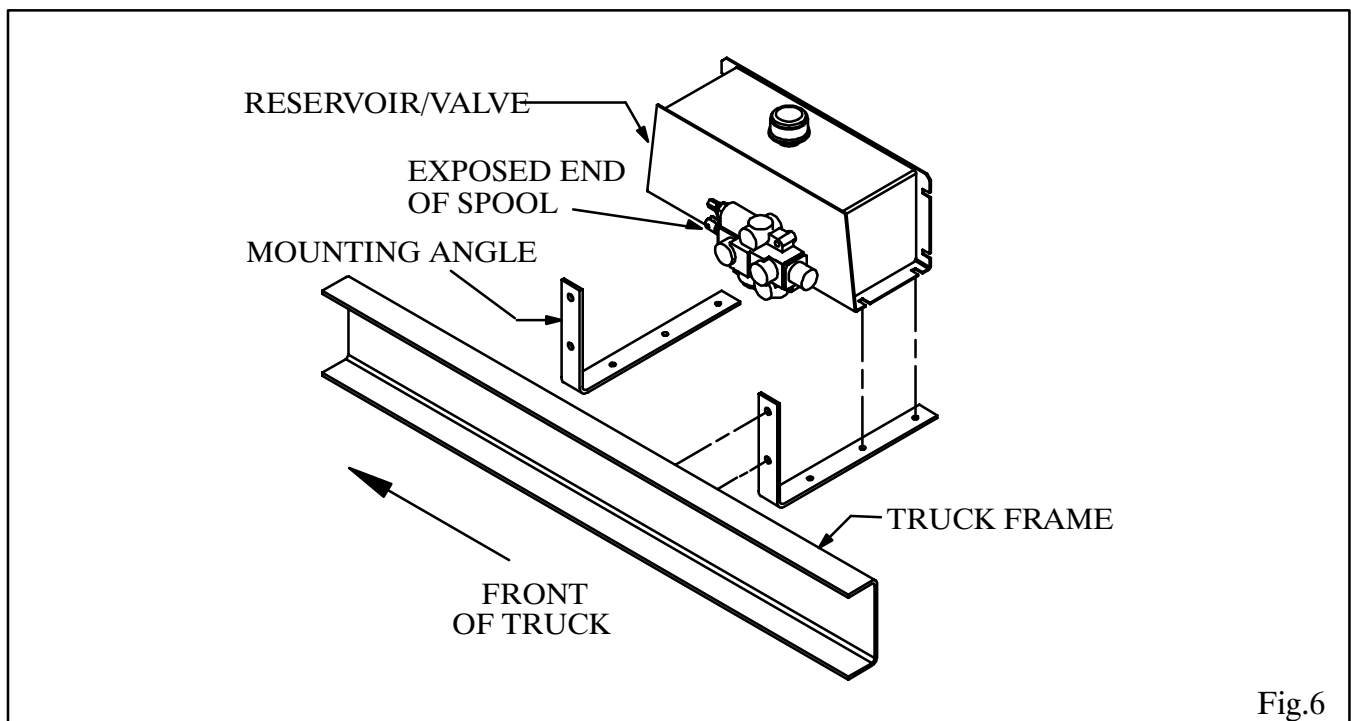

Fig.6

***CAUTION: BE CAREFUL OF BRAKELINES, WIRING, ETC. INSIDE THE TRUCK FRAME WHEN DRILLING THE TRUCK FRAME.***

Drill 17/32" holes in the truck frame and bolt the reservoir/valve assembly in place using 1/2 x 2" cap screws and hex lock nuts, tightening to 90 to 100 lb-ft.

## MOUNT RESERVOIR/VALVE ASSEMBLY – D-10 (DAVID), E-15 (ERNIE), F-18 (FLOYD) & H-25 (HENRY)

The reservoir/valve assembly should be mounted on the same side of the truck as the pump with the exposed end of the valve spool toward the front. Bolt the mounting angles to the reservoir/valve assembly using 3/8 x 1 cap screws, flat washers and hex lock nuts, tightening to 24 to 26 lb–ft. Place the reservoir/valve assembly inside the truck frame and raise it as high as possible. See Figure 5. (There is no drive line to align and the reservoir should be higher than the pump for reliable performance.) Make sure there is enough clearance for the truck drive line and hot exhaust pipes. **THE ENGINE EXHAUST MUST NEVER BLOW DIRECTLY ONTO THE RESERVOIR/VALVE ASSEMBLY.** Clamp the mounting angles to the truck frame and mark the truck frame for drilling using the pump mounting angles as guides.

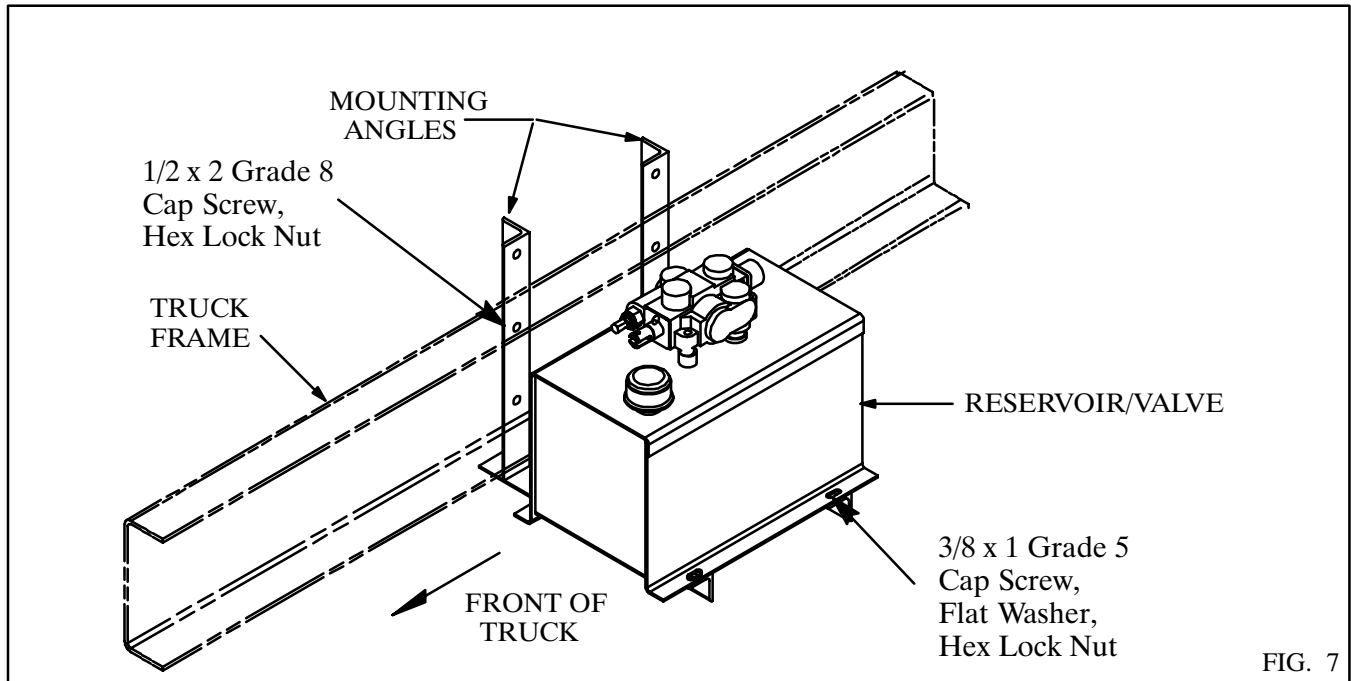

FIG. 7

**CAUTION: BE CAREFUL OF BRAKELINES, WIRING, ETC. INSIDE THE TRUCK FRAME WHEN DRILLING THE TRUCK FRAME.**

Drill 17/32" holes in the truck frame and bolt the reservoir/valve assembly in place using 1/2 x 2 cap screws and hex lock nuts, tightening to 90 to 100 lb–ft.

## INSTALL HOIST CONTROL

Mount the Hoist Control decal on the pedestal taking care to align the holes for the PTO cable and indicator light. Temporarily assemble the valve control head to the pedestal using 5/16 x 2 1/2 machine screws and hex nuts. Place this assembly on the floor of the cab. The pedestal and valve control should angle forward. This makes it convenient for the operator to pull the hoist control lever back to raise the hoist. Make sure there is enough room to operate the valve control and gear shift lever and to adjust the seat. Check below the floor for obstructions and cable routing. Relocate the valve control if necessary. Mark the floor using the pedestal as a template and drill 11/32" holes for the mounting screws and a 3/4" hole for the control cable. Assemble the control cable to the valve control head and assemble the valve control head and cover to the pedestal using 5/16 x 2 1/2 machine screws and hex lock nuts. Insert the control cable through the hole in the floor and mount the pedestal to the floor using 5/16 x 1/2 hex head cap screws, clamping plate (under the floor) and hex lock nuts. Make sure the valve control lever is in its center detent position. Keep the control cable away from hot exhaust pipes and rotating drive shafts. The control cable should not have any sharp bends or kinks in it (these will make the control harder to operate).

Install the 3/4" hex jam nut onto the valve end of the control cable and turn it past the threads. Insert the end of the cable through the bonnet clamp. Install the bonnet onto the control cable and turn it past the threads also. Install the 1/4" hex jam nut and terminal eye on the core rod of the cable; lock the terminal eye to the core rod of the cable using the hex jam nut. Place the terminal eye in the slot of the valve spool; insert the short pin through the valve spool and terminal eye and secure it in place with the 'E' ring. Thread the bonnet onto the end of the cable so it firmly touches the end of the valve. (Do not over- or under-tighten the bonnet as either would move the valve spool out of its neutral position.) Remove two cap screws from opposite corners of the seal retainer plate. Slide the bonnet clamp onto the bonnet and secure it to the valve using the 1/4 x 1/4 cap screws, lock washers and flat washers. Lock the bonnet to the cable using the 3/4" hex jam nut. (See Fig. 8.)

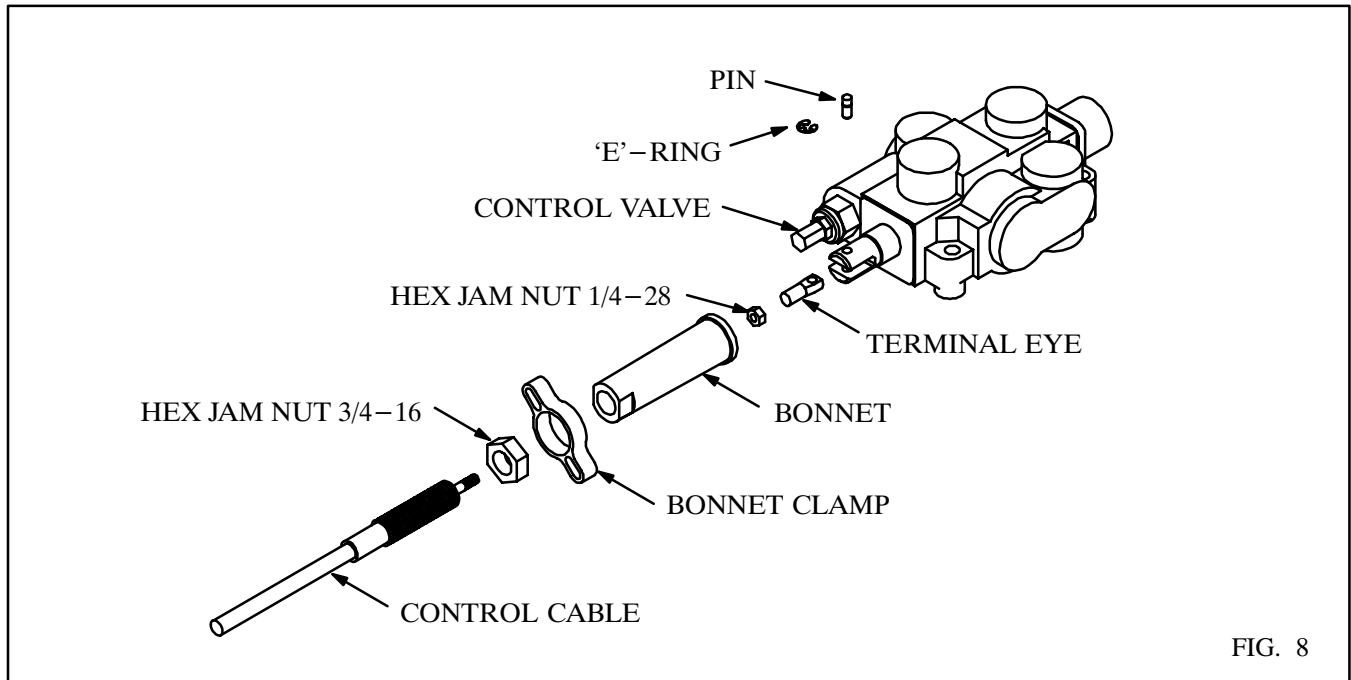

## INSTALL HOSES – B-5 (BERT), C-8 (CHARLIE) & D-9 (DANIEL)

Study Fig. 9 very carefully before connecting hoses. Install a 90° street elbow and a 3/4" hose barb in the suction port on the bottom of the reservoir. Install a 1 1/16 ORB x 3/4" hose barb in the suction port of the pump and install a 3/4" ID suction hose. Secure the suction hose in place using hose clamps. Install a 1 1/16 ORB x 3/8 NPT adapter and a 3/8 NPT 90° swivel adapter in the 'IN' port of the control valve and a 7/8 ORB x 3/8 NPT adapter in the pressure port of the pump. Connect a 72" long 3/8" hose between the pump and the valve.

Install 3/4 ORB male x 3/4 JIC male 90° adapters in the work ports of the control valve and 9/16 ORB male x 3/4 JIC male straight adapters in the ports on the cylinder. Connect the shorter 3/8" hose with 3/4 JIC fittings from the 'B' port on the control valve to the base end port on the cylinder; connect the longer 3/8" hose with 3/4 JIC fittings from the 'A' port to the rod end port. This will raise the hoist when the control lever is pulled back and lower it when pushed forward.

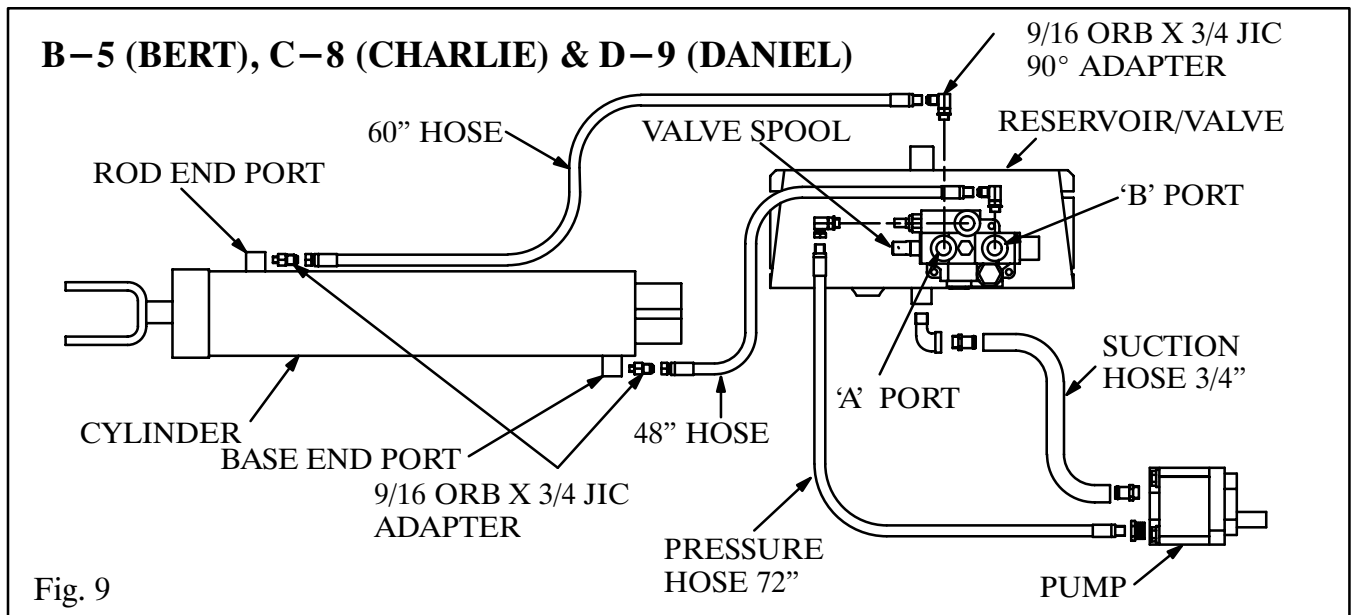

**NOTE:** The 'A' port is the 'power-down' port and has a pressure of only 500–1000 PSI; the 'B' port has full system pressure.

## INSTALL HOSES – D-10 (DAVID), E-15 (ERNIE) & F-18 (FLOYD)

Study Fig. 10 very carefully before connecting the hoses. Install a 90° street elbow and a hose barb in the suction port on the bottom of the reservoir. Install a hose barb in the suction port of the pump and install the suction hose. Secure the suction hose in place using hose clamps.

Install a 90° swivel adapter in the ‘IN’ port of the control valve and install a reducing adapter in the pressure port of the pump. Install the 1/2” ID, 72” long hose (3500 psi minimum pressure rating) from the pump to the valve. Install 7/8 ORB male x 3/4 JIC male 90° adapters in the work ports of the control valve. Install 3/4 ORB male x 3/4 JIC male straight adapters in the ports on the cylinder.

Connect the shorter 3/8” hose with 3/4 JIC fittings from the base end port of the cylinder to the ‘B’ port on the control valve. Connect the longer 3/8” hose with 3/4 JIC fittings from the rod end port of the cylinder to the ‘A’ port on the control valve. This will raise the hoist when the control lever is pulled back and lower it when pushed forward.

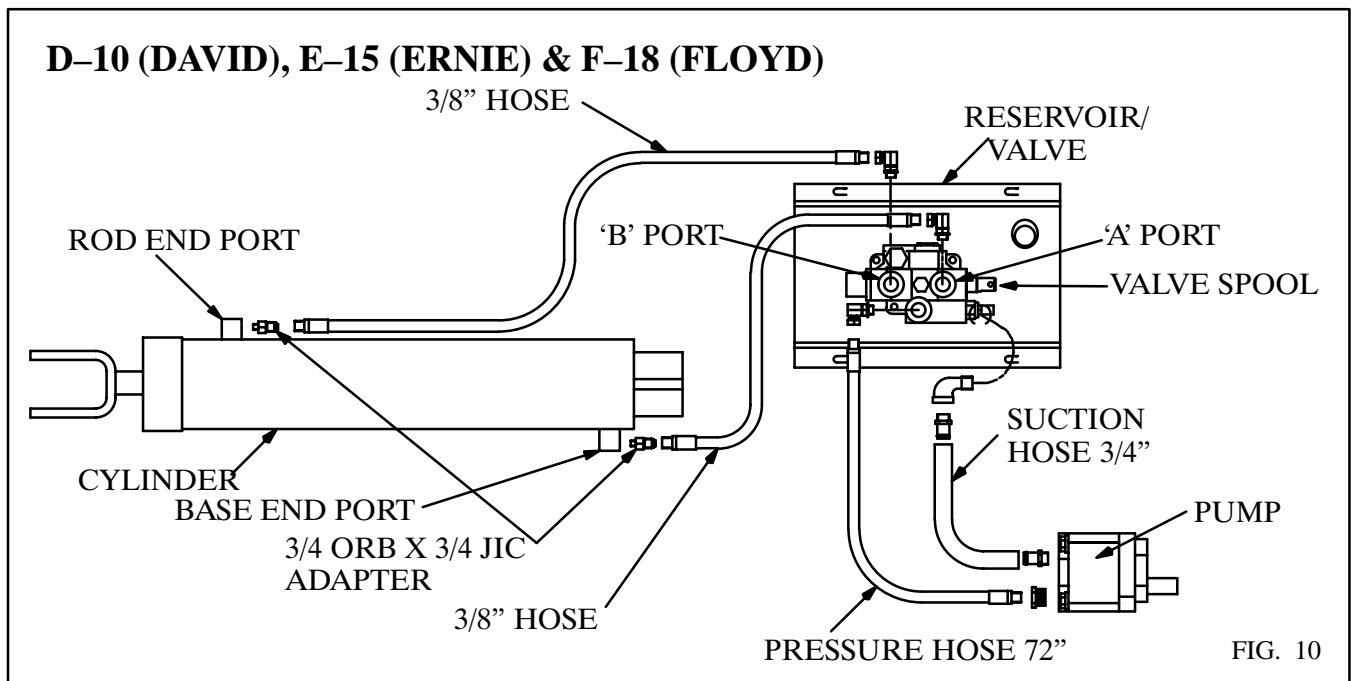

**NOTE:** The ‘A’ port is the ‘power–down’ port and has a pressure of only 500–1000 PSI; the ‘B’ port has full system pressure.

## INSTALL HOSES – H-25 (HENRY)

Study Fig. 11 very carefully before connecting the hoses. Install a 90° street elbow and a hose barb in the suction port on the bottom of the reservoir. Install a hose barb in the suction port of the pump and install the suction hose. Secure the suction hose in place using hose clamps.

Install a 90° swivel adapter in the ‘IN’ port of the control valve and install a reducing adapter in the pressure port of the pump. Install a 72” long hose (4000 psi minimum pressure rating) from the pump to the valve. Install 90° swivel adapters in the work ports of the control valve.

Install straight adapters in the ports on the cylinder. Connect 12” long and 18” long hoses to the cylinders and 3/4 JIC tees as shown in Fig. 11. Place the 12” long hoses on the same side of the truck as the valve/tank assembly.

Connect the shorter 3/8” hose with 3/4 JIC fittings from the tee joining the hoses connecting the base end ports of the cylinder to the ‘B’ port on the control valve. Connect the longer 3/8” hose with 3/4 JIC fittings from the tee joining the hoses connecting the rod end ports of the cylinder to the ‘A’ port

on the control valve. This will raise the hoist when the control lever is pulled back and lower it when pushed forward.

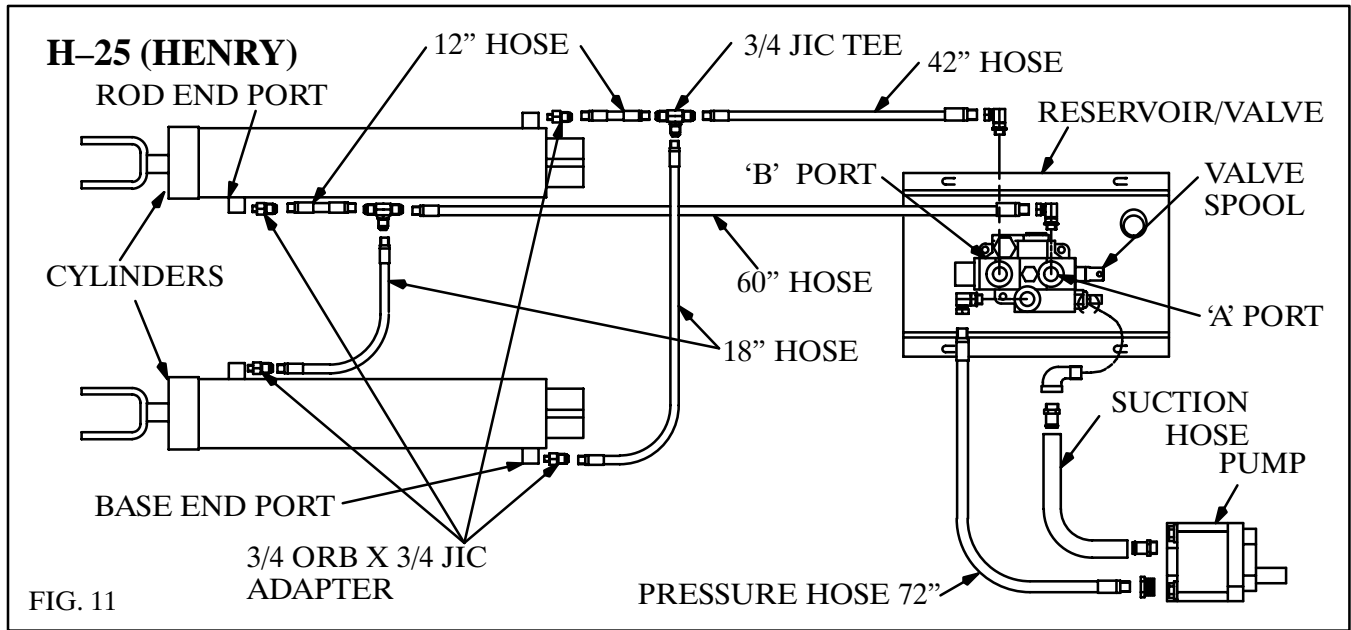

**NOTE:** The ‘A’ port is the ‘power-down’ port and has a pressure of only 500–1000 PSI; the ‘B’ port has full system pressure.

### ADD HYDRAULIC OIL

Use a quality hydraulic fluid of ISO VG Grade 32 which contains corrosion and oxidation inhibitors and a foam depressant. This is approximately the equivalent of SAE 10W or lighter weight oil. Initially fill the reservoir according to the following table. **DO NOT OVERFILL THE RESERVOIR!**

***KEEP THE OIL CLEAN! USE CLEAN CONTAINERS, FUNNELS AND OTHER EQUIPMENT!***

Model	Reservoir Size	Fluid Required
B-5 (BERT)	15 Quarts	10 Quarts
C-8 (CHARLIE)	15 Quarts	10 Quarts
D-9 (DANIEL)	15 Quarts	10 Quarts
D-10 (DAVID)	6 Gallons	4 Gallons
E-15 (ERNIE)	6 Gallons	4 Gallons
F-18 (FLOYD)	8 Gallons	5.5 Gallons

**NOTE:** If the pump does not pump oil, pressurize the reservoir and engage the pump with the engine at slow idle. Once the pump is working, release the pressure and install the breather cap.

For the B-5 (Bert) model hoist, fully raise and lower the hoist several times to remove air from the cylinder and hoses. For C-8 (Charlie), D-9 (Daniel), D-10 (David), E-15 (Ernie), F-18 (Floyd) and H-25 (Henry) hoist models, fully raise the hoist and hold the hoist control in the ‘RAISE’ position for 20 to 30 seconds. This will remove the air that is inside the cylinder(s). Lower the hoist and check the fluid level in the reservoir; the reservoir should be 2/3 full with the body down.

With normal use and working conditions the hydraulic oil should be changed annually. The breather cap should be cleaned every time the hydraulic oil is changed. With heavy use or very dusty working conditions the hydraulic oil should be changed more often.

## ELECTRIC POWER UNIT MOUNTING – GENERAL

The electric power unit should be mounted close behind the cab, either inside or outside the truck frame. After determining where to mount the power unit, bolt one mounting angle to the power unit using the 3/8 x 1 hex head cap screws, tightening to 24 to 26 lb–ft. (See Fig. 12.) Clamp the mounting bracket to the truck frame. Clamp the second mounting angle to the truck frame so it supports the far end of the reservoir. Insert a rubber pad between the mounting angle and the reservoir; and secure it in place with a tie strap. Mark the truck frame for drilling using the pump mounting angles as guides.

Note: The single–acting electric power unit for E–15 (Ernie) and F–18 (Floyd) has a steel tank. Bolt both mounting angles to the tank and clamp them to the truck frame. Mark the truck frame for drilling using the pump mounting angles as guides.

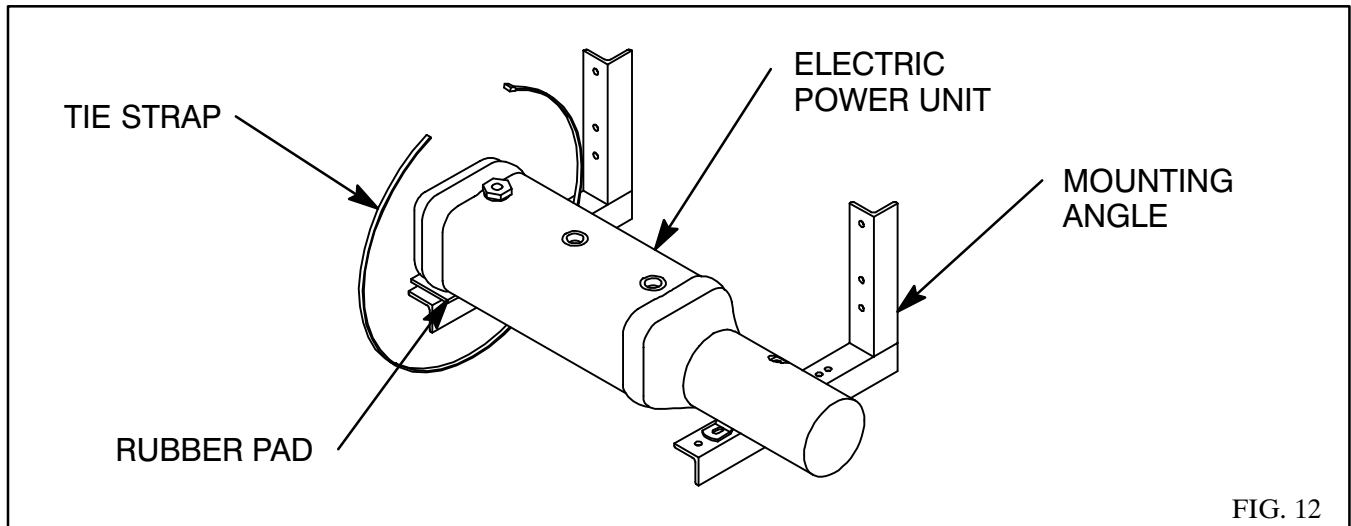

FIG. 12

***CAUTION: BE CAREFUL OF BRAKELINES, WIRING, ETC. INSIDE THE TRUCK FRAME WHEN DRILLING THE TRUCK FRAME.***

Drill 17/32” holes in the truck frame and bolt the reservoir/valve assembly in place using 1/2 x 2 cap screws and hex lock nuts, tightening to 90 to 100 lb–ft.

For rated performance, the voltage at the power unit must be a minimum of 12VDC. This should be measured between the large terminal of the start solenoid (where the battery cable is connected) and the power unit base. NOTE: Grounding of the power unit is just as important as the installation of the positive battery cable. It is easier to get a good ground by using a second battery cable.

Connect the large terminal on the motor start solenoid to the positive terminal on the battery with a #0 gauge battery cable. Grounding of the power unit can be completed either through the vehicle chassis or by a second battery cable. If grounding through the vehicle chassis, be sure to replace the light ground strap between the battery and the vehicle chassis with a #0 gauge cable. If grounding with a second battery cable, connect the negative terminal on the battery to the grounding hole on the power unit base using an #0 size battery cable. See Figure 10. Check the voltage between the large terminal on the start solenoid and the power unit base.

R  
E-  
V  
I  
S  
E  
D

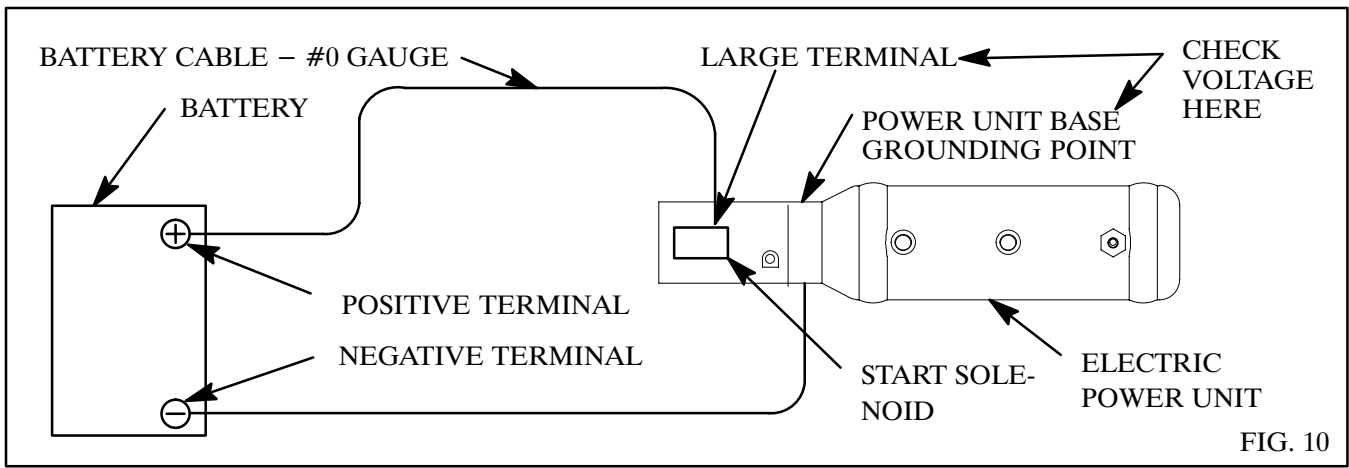

Locate the push-button control in the cab and route the cable out of the cab through a hole in the back of the cab. Connect the push-button control to the electric power unit using the 3-pin connector set. Clamp the motor solenoid cover to the motor using the long tie-strap included with the electric power unit.

### INSTALL HOSES – SINGLE-ACTING

Install a 3/8 NPT x 3/4-16 JIC male elbow in the power port on the electric pump and install a 1/4 NPT x 3/4-16 JIC male elbow in the port on the top of the reservoir.

For the B-5 (Bert), C-8 (Charlie) & D-9 (Daniel) models, install 9/16 ORB male x 3/4 JIC male adapters in both ports on the cylinder. For the D-10 (David), E-15 (Ernie) & F-18 (Floyd) models, install 3/4 ORB male x 3/4 JIC male adapters in both ports on the cylinder.

Connect the shorter 3/8" hose with 3/4 JIC fittings from the base end port of the cylinder to the power port on the electric power unit. Connect the longer 3/8" hose with 3/4 JIC fittings from the rod end port of the cylinder to the port on the reservoir. (See Fig. 14.)

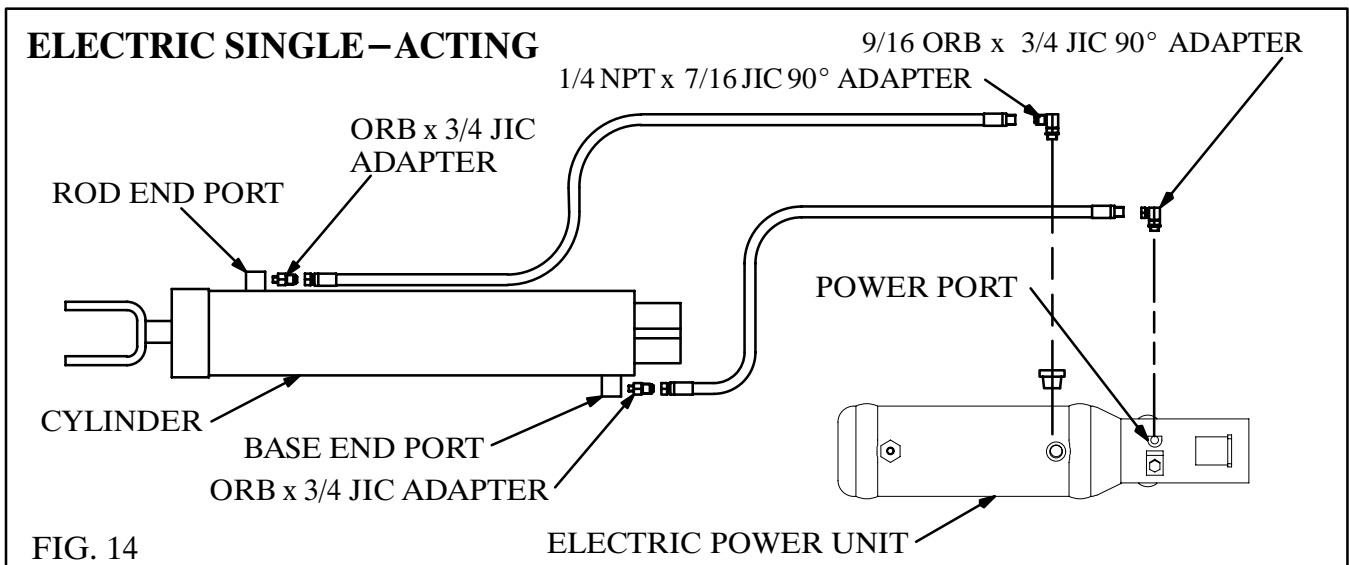

### INSTALL HOSES – DOUBLE-ACTING

Install 9/16 ORB x 3/4 JIC 90° swivel adapters in both work ports on the electric pump. If needed, for good hose routing, install 3/4 JIC x 3/4 JIC 90° swivel adapters to both of these adapters.

For the B-5 (Bert), C-8 (Charlie) & D-9 (Daniel) models, install 9/16 ORB male x 3/4 JIC male adapters in both ports on the cylinder. For the D-10 (David), E-15 (Ernie) & F-18 (Floyd) models, install 3/4 ORB male x 3/4 JIC male adapters in both ports on the cylinder.

Connect the shorter 3/8 ID hose with 3/4 JIC fittings from the 'C1' port on the pump to the base end port on the cylinder. Connect the longer 3/8" ID hose with 3/4 JIC fittings from the 'C2' port to the rod end port. (See Fig. 15.)

*NOTE: The 'C2' port is the power down port and has only 500 PSI maximum pressure.*

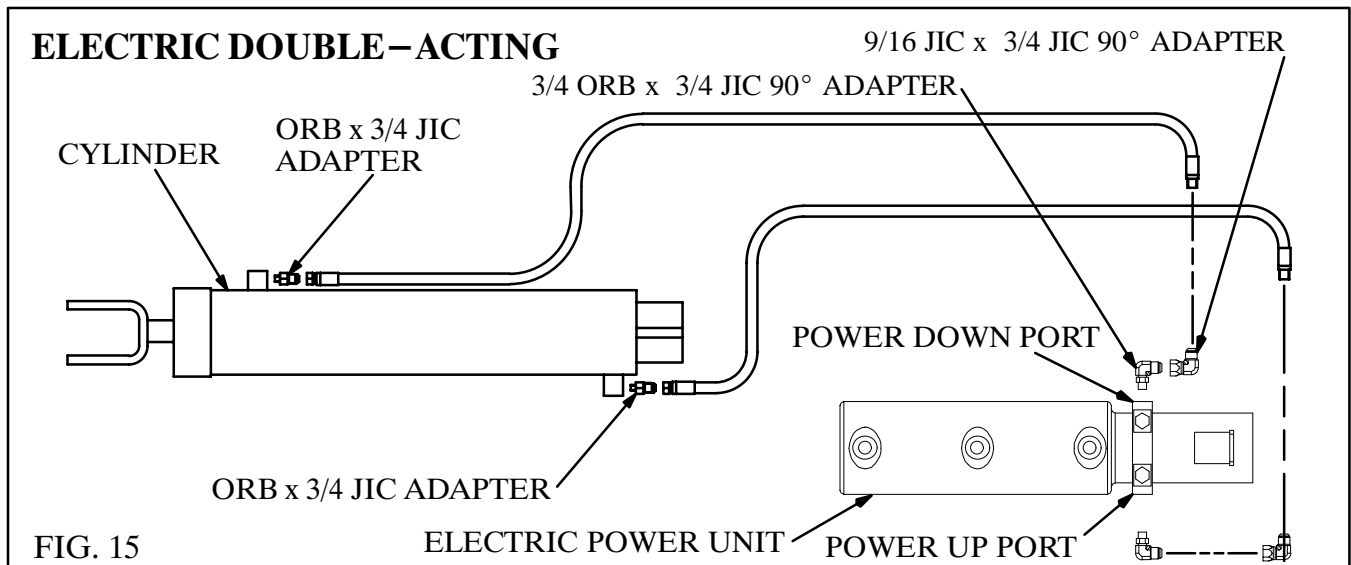

### ADD AUTOMATIC TRANSMISSION FLUID

Initially fill the reservoir with DEXRON III automatic transmission fluid. Refer to the following table for the amount. **DO NOT OVERFILL THE RESERVOIR!** Raise and lower the hoist several times and check the fluid level in the reservoir. Add fluid as needed.

Model	Single-Acting	Double-Acting
B-5 (BERT)	7 Quarts	7 Quarts
C-8 (CHARLIE)	7 Quarts	7 Quarts
D-9 (DANIEL)	7 Quarts	7 Quarts
D-10 (DAVID)	7 Quarts	7 Quarts
E-15 (ERNIE)	18 Quarts	7 Quarts
F-18 (FLOYD)	18 Quarts	7 Quarts

### ***KEEP THE FLUID CLEAN! USE CLEAN CONTAINERS, FUNNELS AND OTHER EQUIPMENT!***

For the B-5 (Bert) model hoist, fully raise and lower the hoist several times to remove air from the cylinder and hoses.

For C-8 (Charlie), D-9 (Daniel), D-10 (David), E-15 (Ernie) and F-18 (Floyd) hoist models with single-acting power units, fully raise the hoist and hold the 'UP' button for 20-30 seconds. This will remove the air that is inside the cylinder. Lower the hoist and check the fluid level in the reservoir; the fluid level should be within 1" of the top of the reservoir with the body down.

For C-8 (Charlie), D-9 (Daniel) and D-10 (David) hoist models with double-acting power units, fully raise the hoist and hold the 'UP' button for 20-30 seconds. For E-15 (Ernie) and F-18 (Floyd) hoist models with double-acting power units, raise the hoist until there is 2" of ATF in the reservoir. Add 2 quarts and raise the hoist until there is 2" of ATF in the reservoir. Repeat this until the hoist

can be fully raised. Fully raise the hoist and hold the 'UP' button for 20–30 seconds. This will remove the air that is inside the cylinder. Lower the hoist and check the fluid level in the reservoir; the fluid level should be within 1" of the top of the reservoir with the body down.

With normal use and working conditions the automatic transmission fluid should be changed annually. The breather cap should be cleaned every time the fluid is changed. With heavy use or very dusty working conditions the fluid should be changed more often.

## MOUNT BODY

It is recommended that the body be painted before it is mounted on the truck. Place the body in position on the truck with three inches of clearance behind the cab. Use the rivet strips to fill the space between the longbeams and the truck frame. Use three on each side, one near the front of the body and two evenly spaced between the hoist mount and the rear hinge. Weld them to the longbeams. Align the body longbeams carefully with the truck frame. Securely weld the longbeams to the rear hinge brackets and to the upper hoist pivot pads.

On the inside of the longbeams, securely weld the longbeam fillers to the top of the upper hoist pivot pads and to the top flange of the longbeam channels as shown in Figure 16. For Crysteel's Grain Tipper, place the 9 inch square plate between the angle lift bracket and the inside of the longbeam as shown in Figure 17. Securely weld this plate to the longbeam and to the upper hoist pivot pad. Be sure to do this on both sides.

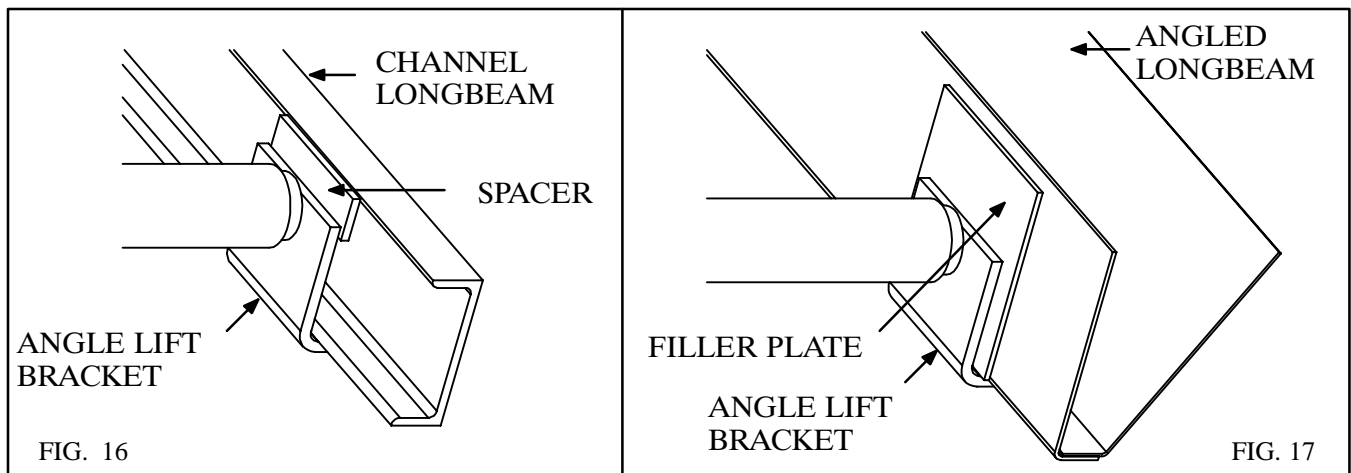

***DO NOT WORK UNDER A RAISED BODY UNLESS THE BODY IS SECURELY BLOCKED OR PROPPED IN THE RAISED POSITION.***

See specifications on page 34 for minimum floor heights.

## INSTALL BODY GUIDE PLATES

Crysteel recommends that plates be installed on the inside of the body longbeams to work with the body guides built into the hoist frame to keep the body and truck frame aligned when the body is down. (See Fig. 18.)

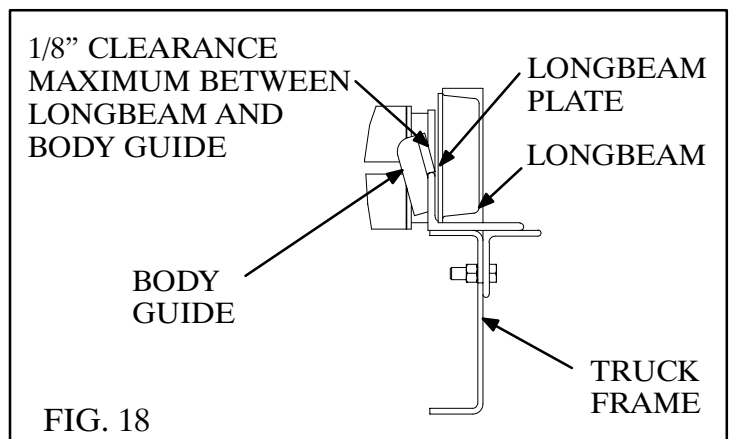

## INSTALL BODY PROP

The body prop is designed and intended to support an EMPTY truck body in the raised position. Use of the body prop permits service to be performed safely beneath a raised body. It is mounted on the outside of the truck frame on the drivers side.

1. Raise the body half way up and brace it securely before beginning installation.
2. Install the prop arm on the hoist mount / prop pivot with a 1/4 x 3 roll pin. Raise the body prop arm to the vertical, free standing position. Place the body prop bracket in the prop arm saddle. Lower the body so the bottom of the longbeam body prop bracket is between 1/2" and 1 1/2" up from the bottom of the body longbeam. For bodies with angled longbeams, keep the longbeam body prop bracket as low as possible. Securely weld the bracket to the longbeam.
3. To operate the body prop, raise the body to the desired height, shut off all power, raise the prop arm to a free standing position. Lower the body slowly until the body prop bracket contacts the prop arm saddle.
4. To place the body prop in the storage position, raise the body to clear the body prop saddle, lower the body prop to the storage position and lower the body.

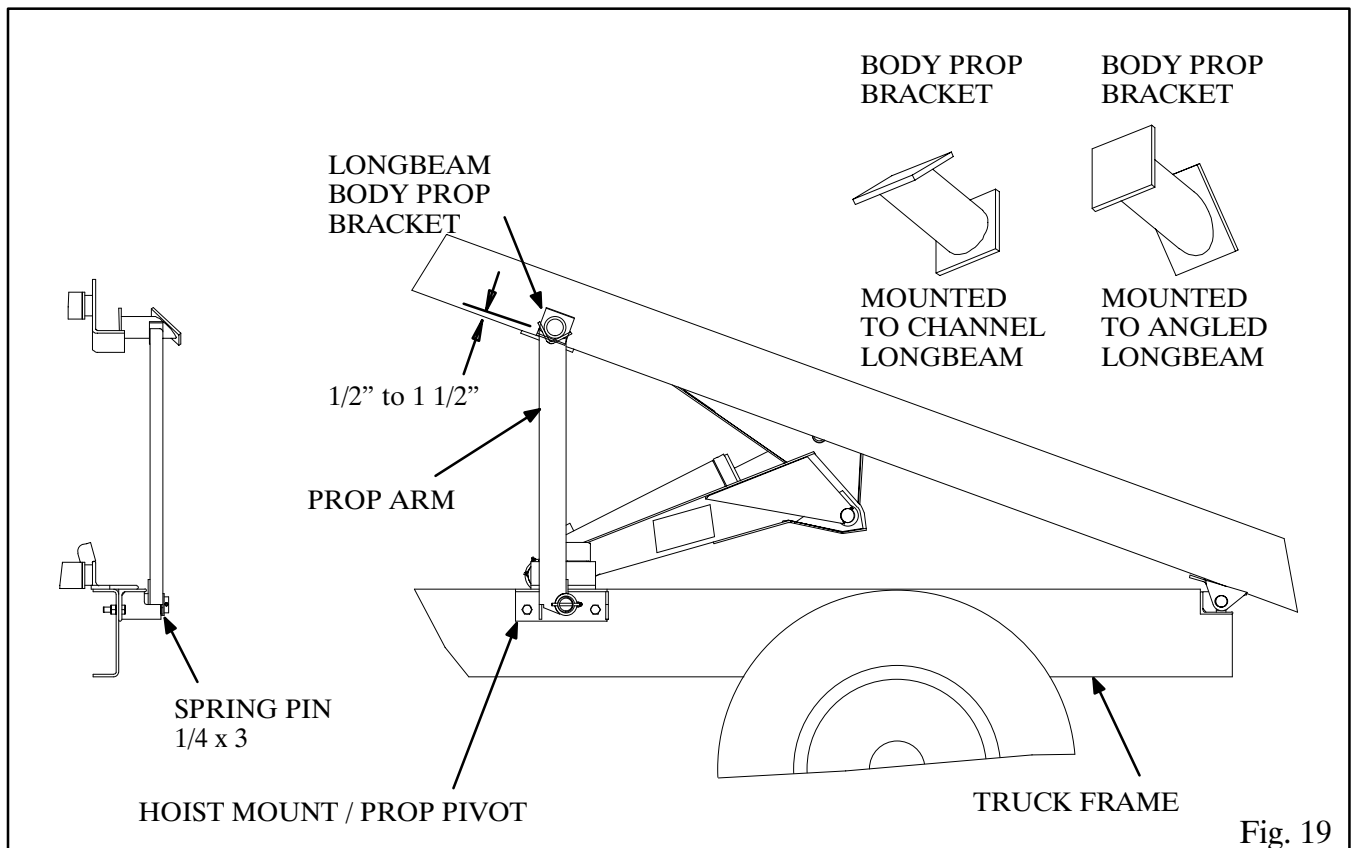

An optional passenger's side prop kit is available.

5. When mounting the passenger's side prop, replace the hoist mounting angle with the hoist mount/prop pivot. Prop the body in the raised position using the driver's side prop. This will ensure that both props are supporting the empty body.

## INSTALL GREASE ZERKS AND LUBRICATE

Install grease zerks in the hoist frame. Lubricate all fittings at regular intervals, at least every 100 cycles or every two months. The grease fittings are located (See Fig. 20.) as follows:

- A. Rear Hinge . . . . . 2 fittings (already installed)
- B. Lower Cylinder Mount . . . . . 1 or 2 fitting(s)
- C. Lower Crosstube . . . . . 2 fittings
- D. Upper Crosstube . . . . . 2 fittings
- E. Cylinder Crosshead . . . . . 1 90° fitting
- F. Center Hinge . . . . . 1 or 2 fitting(s)
- G. Body Prop . . . . . 1 90° fitting

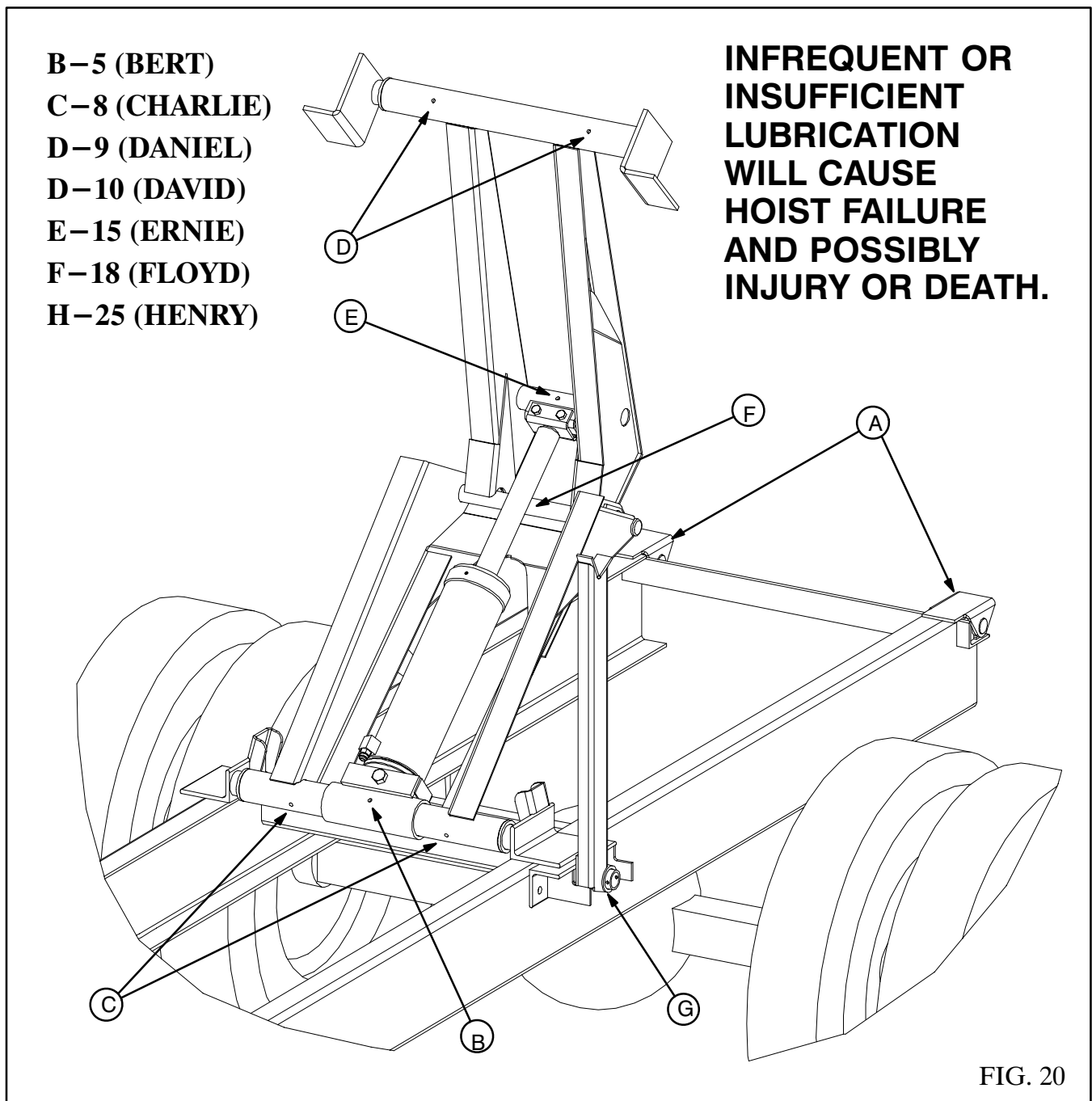

# INSTALL DECALS

Mount decals in the proper places as shown in Figure 21.

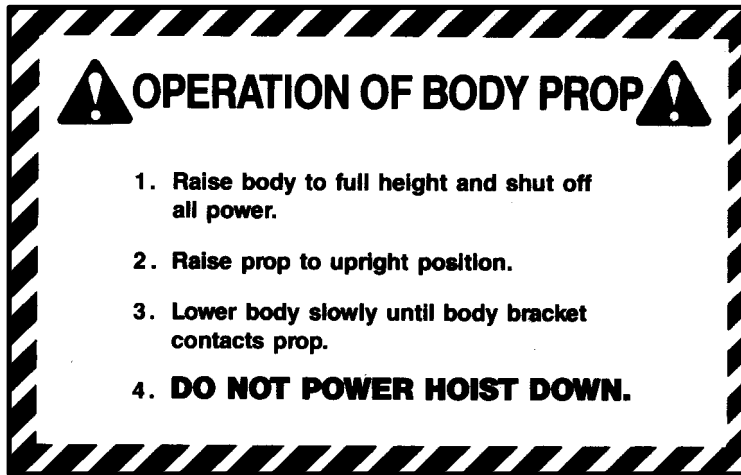

400719—Mount on the body longbeam near the body prop

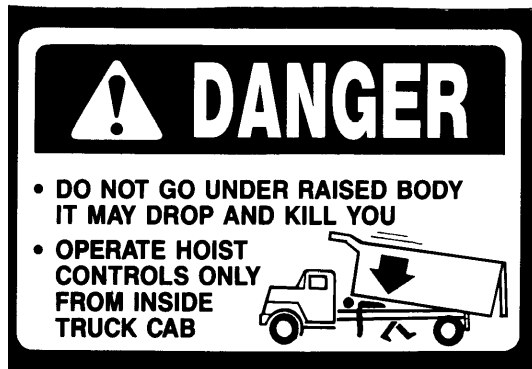

401576—Mount on the outside of the body longbeams near the front of the body (one on each side).



400643—Mount on the longbeam on the drivers side.

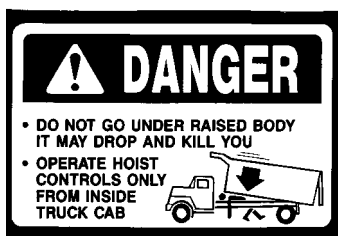

401577—Mount in the cab in a prominent location

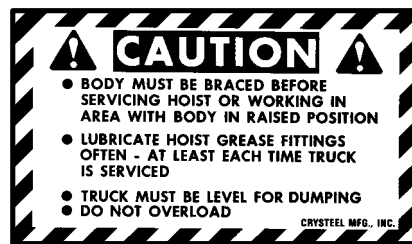

400642—Mount in the cab in a prominent location



400661—Mount on the body prop arm.

Fig. 21

**B-5 (BERT), C-8 (CHARLIE), D-9 (DANIEL), D-10 (DAVID), E-15 (ERNIE)  
& F-18 (FLOYD) HOIST PARTS**

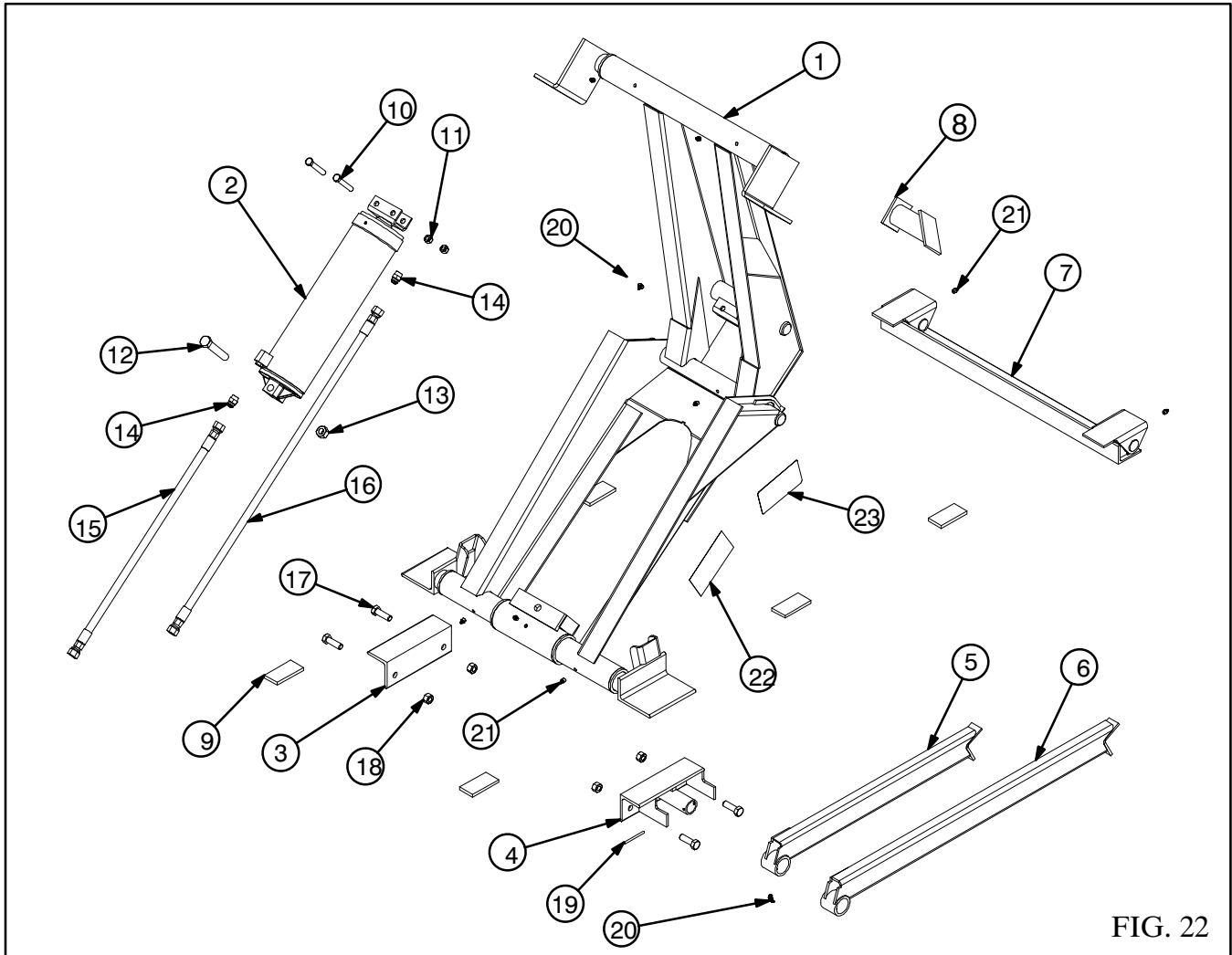

FIG. 22

NO.	DE- SCRIPTION	MODEL B-5 (BERT)	MODEL C-8 (CHARLIE)	MODEL D-9 (DANIEL)	MODEL D-10 (DAVID)	MODEL E-15 (ERNIE)	MODEL F-18 (FLOYD)	QTY
1.	Assy Frame	156995	156995	156995	152731	153365	155548	1
2.	Assy Cylinder	105528	110304	119106	152735	153367	155102	1
3.	Mounting Angle	201422	201422	201422	201422	201422	201422	1
4.	Assy Mount/ Pivot – Drive	159267	159267	159267	159267	159267	159267	1
	Assy Mount/ Pivot – Pass	159268	159268	159268	159268	159268	159268	1
5.	Assy Prop Arm 30” – Drive	158744	158744	158744	158744	158744		1
	Assy Prop Arm 30” – Pass	158745	158745	158745	158745	158745		1

NO.	DE- SCRIPTION	MODEL B-5 (BERT)	MODEL C-8 (CHAR- LIE)	MODEL D-9 (DAN- IEL)	MODEL D-10 (DA- VID)	MODEL E-15 (ER- NIE)	MODEL F-18 (FLOYD )	QTY
6.	Assy Prop Arm 42" – Drive						159273	1
	Assy Prop Arm 42" – Pass						159274	1
7.	Assy Rear Hinge	108129	108129	108129	106060	106060	106060	1
8.	Assy Prop Bracket	159277	159277	159277	159277	159277	159277	1
9.	Spacer Long- beam	200892	200892	200892	200892	200892	200890	6
10.	Cap Screw 1/2-13 x 3 1/4 Gr 5	401140	401140	401140	401140	401140	401140	2
11.	Hex Lock Nut 1/2-13	401316	401316	401316	401316	401316	401316	2
12.	Cap Screw 3/4-10 x 4 Gr 8	401237	401237	401237				1
	Cap Screw 3/4-10 x 4 1/2 Gr 8				401225	401225	401225	1
13.	Hex Lock Nut 3/4-10	401226	401226	401226	401226	401226	401226	1
14.	Adapter 9/16 ORB x 3/4 JIC	402516	402516	402516				2
	Adapter 3/4 ORB x 3/4 JIC				403590	403590	403590	2
15.	Hose 3/4 JIC x 36"						404898	1
	Hose 3/4 JIC x 42"				402489	402489		1
	Hose 3/4 JIC x 48"	402490	402490	402490				1
16.	Hose 3/4 JIC x 60"	402517	402517	402517	402517	402517		1
	Hose 3/4 JIC x 66"						403311	1
17.	Cap Screw 5/8-11 x 2 Gr 8	402374	402374	402374	402374	402374	402374	4

18.	Hex Lock Nut 5/8-11	401582	401582	401582	401582	401582	401582	4
19.	Roll Pin 1/4 x 3	400220	400220	400220	400220	400220	400220	1
20.	Grease Zerk 1/8 90° NPT	400117	400117	400117	400117	400117	400117	2
NO.	DE- SCRIPTION	MODEL B-5 (BERT)	MODEL C-8 (CHAR- LIE)	MODEL D-9 (DAN- IEL)	MODEL D-10 (DA- VID)	MODEL E-15 (ER- NIE)	MODEL F-18 (FLOYD )	QTY
21.	Grease Zerk 1/8 NPT	400103	400103	400103	400103	400103	400103	8
22.	Decal LoBoy	406646	406646	406646	406646	406646	406646	1
23.	Decal Lubrica- tion	406914	406914	406914	406914	406914	406914	1
24.	Decal Kit	159693	159693	159693	159393	159693	159693	1
25.	Driver Side Prop Kit	159694	159694	159694	159694	159694	159696	1
26.	Passenger Side Prop Kit	159695	159695	159695	159695	159695	159697	1

### NOTES

## H-25 (HENRY) HOIST PARTS

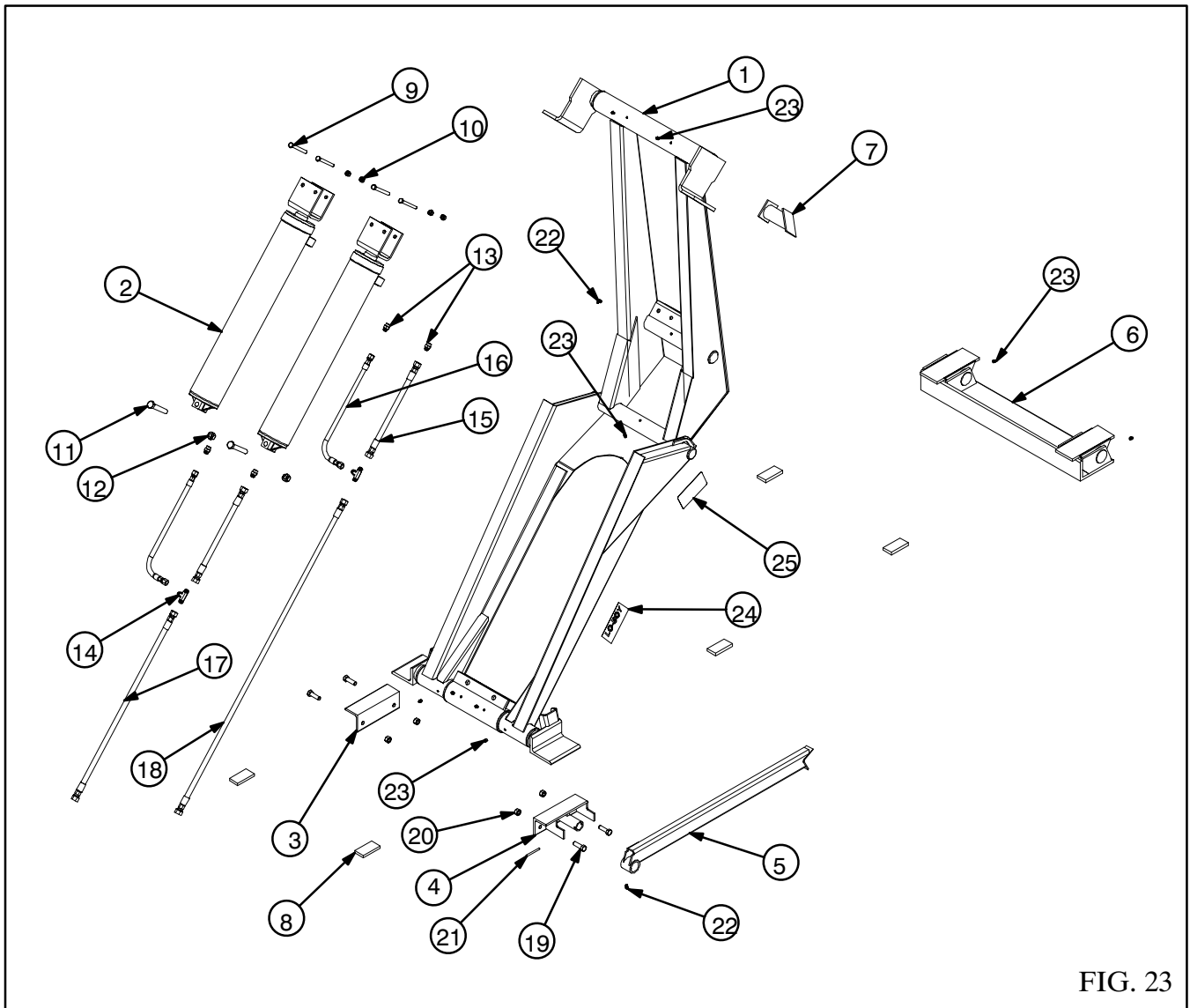

FIG. 23

NO.	DESCRIPTION	MODEL H-25 (HENRY)	QTY
1.	Assy Frame	155548	1
2.	Assy Cylinder	155102	1
3.	Angle Mounting	201422	1
4.	Assy Mount/Pivot – Driver	159267	1
	Assy Mount/Pivot – Passenger	159268	1
5.	Assy Prop Arm 42” – Driver	159273	1
	Assy Prop Arm 42” – Passenger	159274	1
6.	Assy Rear Hinge	107037	1
7.	Assy Prop Bracket	159277	2
8.	Spacer Longbeam	200890	6
9.	Cap Screw	1/2-13 x 4 1/2 Gr 5 400135	4

NO.	DESCRIPTION	MODEL H-25 (HENRY)	QTY
10.	Hex Lock Nut 1/2-13	401316	4
11.	Cap Screw 3/4-10 x 4 1/2 Gr 8	401225	2
12.	Hex Lock Nut 3/4-10	401226	2
13.	Adapter 3/4 ORB x 3/4 JIC	403590	4
14.	Tee 3/4 JIC Male	406808	2
15.	Hose 3/4 JIC x 18"	402488	2
16.	Hose 3/4 JIC x 21"	402491	2
17.	Hose 3/4 JIC x 36"	404898	1
18.	Hose 3/4 JIC x 66"	403311	1
19.	Cap Screw 5/8-11 x 2 Gr 8	402374	4
20.	Hex Lock Nut 5/8-11	401582	4
21.	Roll Pin 1/4 x 3	400220	2
22.	Grease Zerk 1/8 90° NPT	400117	2
23.	Grease Zerk 1/8 NPT	400103	9
24.	Decal LoBoy	406646	1
25.	Decal Lubrication	406914	1
26.	Decal Kit	159693	1
27.	Driver Side Prop Kit	159696	1
28.	Passenger Side Prop Kit	159697	1

### NOTES

## CYLINDER PARTS

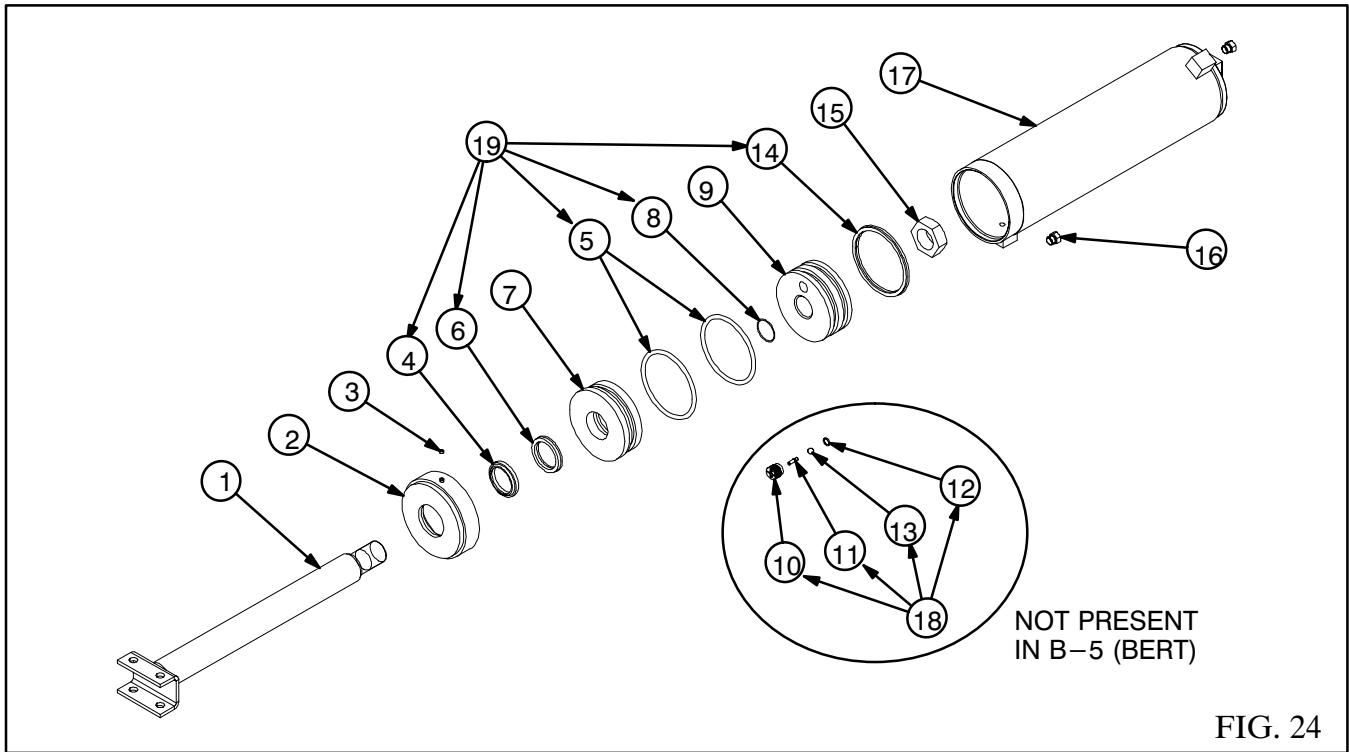

FIG. 24

NO	DESCRIPTION	MODEL B-5 (BERT)	MODEL C-8 (CHARLIE)	MODEL D-9 (DANIEL)	MODEL D-10 (DAVID)	MODEL E-15 (ERNIE)	MODEL F-18 (FLOYD)	MODEL H-25 (HENRY)	QTY
1.	Shaft Assy	105540	110306	110306	152737	152737	155107	155158	1
2.	Cylinder Cap Assy	105541	104293	104297	104293	104298	104299	104294	1
3.	Set Screw 1/4 x 3/16 Nylon Tip	400149	400149	400149	400149	400149	400149	400149	1
4.	Wiper	401133	400913	400913	400913	400913	400914	400914	1
5.	O-Ring	400263	400254	400276	400254	400258	400258	400254	2
6.	Poly Seal	401132	400253	400253	400253	400253	400907	400907	1
7.	Cylinder Head	206279	202469	227775	202469	205130	205141	205145	1
8.	O-Ring	401131	400255	400255	400255	400255	400255	400255	1
9.	Cylinder Piston	206755	202461	205139	202461	202472	402472	202461	1
10.	Bypass Valve Body		400978	400978	400978	400978	400978	400978	1
11.	Bypass Valve Pin		400979	400979	400979	400979	400979	400979	1
12.	O-Ring 7/16		401017	401017	401017	401017	401017	401017	1
13.	Steel Ball 3/8 Dia		400013	400013	400013	400013	400013	400013	1
14.	Poly Seal	400262	400252	400277	400252	400257	400257	400252	1

NO	DESCRIPTION	MODEL B-5 (BERT)	MODEL C-8 (CHARLIE)	MODEL D-9 (DANIEL)	MODEL D-10 (DAVID)	MODEL E-15 (ERNIE)	MODEL F-18 (FLOYD)	MODEL H-25 (HENRY)	QTY
15.	Hex Jam Nut		401370	401370	401370	401370	401370	401370	1
16.	Plug 9/16-18 ORB	400404	400404	400404	400436	400436	400436	400436	2
17.	Cylinder Tube Assy	105539	110305	119107	152736	153368	155106	155157	1
18.	Bypass Valve Kit		105185	105185	105185	105185	105185	105185	1
19.	Seal Kit	107958	107960	107961	107960	107962	107962	107960	1

**NOTES**

**B-5 (BERT)/C-8 (CHARLIE)/D-9 (DANIEL) HYDRAULIC SYSTEM PARTS**

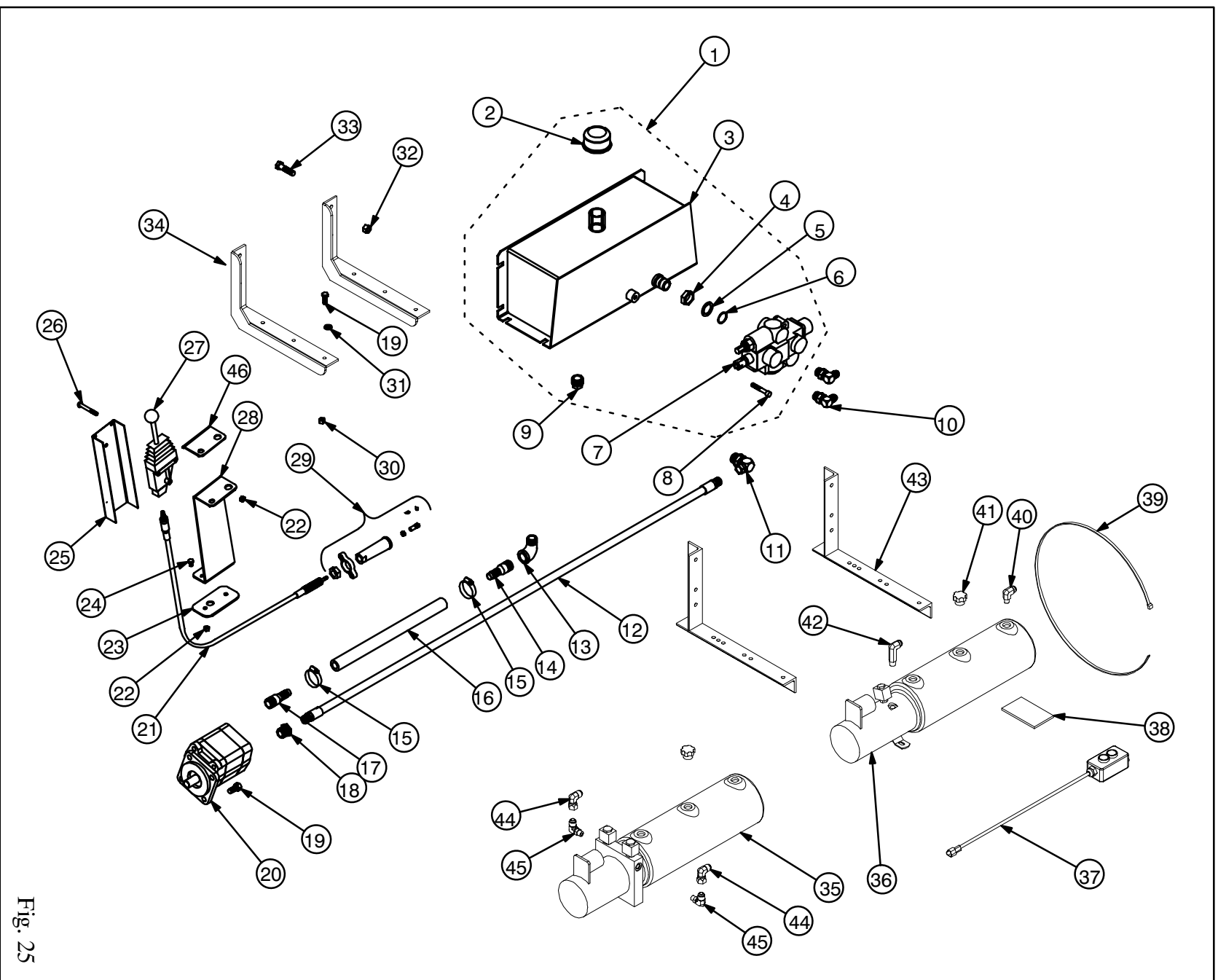

Fig. 25

NO.	DESCRIPTION	MODEL	PART NO.	QTY.
1.	Assy Reservoir/Valve 15 Qt 3250 DA	All	125803	1
2.	Breather Cap	All	400764	1
3.	Assy Reservoir	All	124998	1
4.	Hex Jam Nut 7/8-14	All	402094	1
5.	Cone Washer 7/8	All	402095	1
6.	O-Ring .755 ID x .097 CS	All	402096	1
7.	Control Valve 12 GPM 3250 DA	All	402813	1
8.	Hex Head Cap Screw 1/4-20 x 1 3/4 Gr 5	All	401546	1
9.	Pipe Plug 3/4 Magnetic	All	400405	1
10.	Adapter 3/4 ORBM x 3/4 JICM 90°	All	402487	2
11.	Adapter 7/8 ORBM x 3/8 NPTF 90°	All	401200	1
12.	Hose 3/8 NPT x 72 RM?RM 4000	All	401444	1
13.	Pipe Street Elbow 3/4	All	402144	1
14.	Hose Barb 3/4 NPT x 3/4	All	401447	1
15.	Hose Clamp #24	All	401441	2
16.	Suction Hose 3/4 ID x 72"	All	404911	1
17.	Hose Barb 1 1/16 ORBM x 3/4	All	402146	1
18.	Adapter 7/8 ORBM x 3/8 NPTF	All	400478	1
19.	Hex Head Cap Screw 3/8-16 x 1 Gr 5	All	400121	8
20.	Gear Pump 4 GPM P11 - 9 Tooth	All	402071	1
	Gear Pump 4 GPM P11 - 11 Tooth	All	403768	1
21.	Cable, Valve Control - 96"	All	402122	1
	Cable, Valve Control - 72"	All	402121	1
	Cable, Valve Control - 84"	All	402419	1
	Cable, Valve Control - 120"	All	402123	1
	Cable, Valve Control - 144"	All	402124	1
	Cable, Valve Control - 180"	All	402125	1
	Cable, Valve Control - 240"	All	402126	1
22.	Hex Lock Nut 5/16-18	All	401240	5
23.	Clamp Plate - Pedestal	All	225127	1
24.	Hex Head Cap Screw 5/16-18 x 1/2 Gr 2	All	402415	2
25.	Channel Pedestal	All	223144	1
26.	Machine Screw 5/16-18 x 2 1/2 RH	All	402154	3
27.	Remote Valve Control w/ Center Detent	All	402120	1
28.	Pedestal	All	223143	1
29.	Valve Connection Kit - Prince 4100	All	403171	1
30.	Hex Lock Nut 3/8-16	All	402038	4
31.	Flat Washer 3/8	All	400164	4

NO.	DESCRIPTION	MODEL	PART NO.	QTY.
32.	Hex Lock Nut 1/2-13	All	401316	4
33.	Hex Head Cap Screw 1/2-13 x 2 Gr 8	All	400105	4
34.	Assy Reservoir/Valve Mount	All	120031	2
35.	Electric Pump – DA	All	405287	1
36.	Electric Pump – SA	All	405286	1
37.	Control Push-Button – Electric Pump 10'	All	405289	1
	Control Push-Button – Electric Pump 15'	All	405290	
38.	Rubber Pad 3 x 5	All	405319	1
39.	Cable Tie 33"	All	404956	1
40.	Adapter 3/4 JICM x 1/4 NPTM 90°	All	402510	1
41.	Breather Cap w/ Dipstick	All	405384	1
42.	Adapter 3/4 JICM x 3/8 NPTM Long 90°	All	402509	1
43.	Assy Pump Mounting Angle	All	100174	2
44.	Adapter 3/4 JICM x 3/4 JICF 90°	All	403448	2
45.	Adapter 9/16 ORBM x 3/4 JICM 90°	All	403447	2
46.	Decal – Hoist Control	All	402129	1

### NOTES

# D-10 (DAVID)/E-15 (ERNE)/F-18 (FLOYD)/H-25 (HENRY) HYDRAULIC SYSTEM PARTS

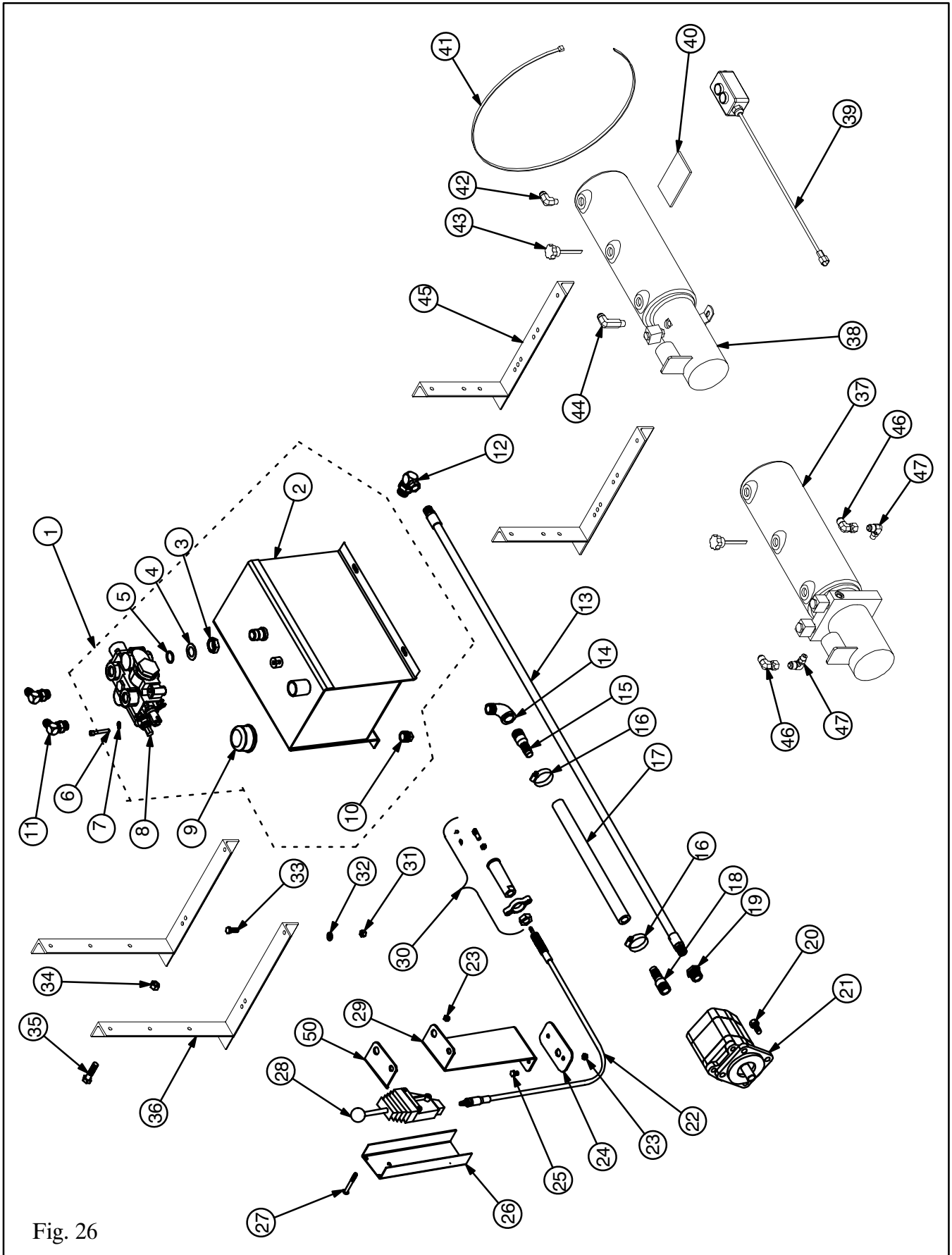

Fig. 26

NO.	DESCRIPTION	D-10 (DAVID)	E-15 (ERNIE)	F-18 (FLOYD)	H-25 (HENRY)	QTY.
1.	Reservoir/Valve Assy (Carton)	116651	116651	116653	116655	1
2.	Reservoir Assy	116361	116361	116361	116350	1
3.	Hex Jam Nut 1 1/16-12	402092	402092	402092	402092	1
4.	Cone Washer 1 1/16	402093	402093	402093	402093	1
5.	O-Ring .924 ID x .116 CS	401094	401094	401094	401094	1
6.	Socket Head Cap Screw 5/16-18 x 2	402115	402115	402115	402115	1
7.	Lock Washer 5/16	400165	400165	400165	400165	1
8.	Control Valve 3250 PSI DA	402065	402065	402065		1
	Control Valve 4000 PSI DA				402068	1
9.	Breather Cap	400764	400764	400764	400764	1
10.	Magnetic Pipe Plug	400405	400405	400405	400205	1
11.	Adapter 7/8 ORBM x 3/4 JICM 90°	402486	402486	402486	402486	2
12.	Adapter 1 1/16 ORBM x 1/2 NPTF 90°	401285	401285	401285	401285	1
13.	Hose 1/2 NPT x 72" 3500 PSI	401445	401445	401445		1
	Hose 7/8 ORB-1/2 NPT x 72" 5000 PSI				401446	1
14.	Street Elbow 3/4"	402144	402144			1
	Street Elbow 1 1/4"			401296	401296	1
15.	Hose Barb 3/4 NPT x 3/4	401447	401447			1
	Hose Barb 1 1/4 NPT x 1 1/4			401449	401449	1
16.	Hose Clamp #24 1 1/16-2	401441	401441			2
	Hose Clamp 1 3/4" T-Bolt			402164	402164	2
17.	Suction Hose 3/4 ID x 72"	404911	404911			1
	Suction Hose 1 1/4 ID x 72"			404912	404912	1
18.	Hose Barb 3/4 NPT x 3/4	401447	401447			1
	Hose Barb 1 5/16 ORB x 1 1/4			401450	401450	1
19.	Hex Bushing 3/4 x 1/2	401091	401091			1
	Adapter 1 5/16 ORB x 1/2 NPT			210608		1
	Adapter 1 5/16 ORB x 7/8 ORB				210612	1
20.	Hex Head Cap Screw 1/2-13 x 1 1/4	400153	400153	400153	400153	4
21.	Gear Pump - 6 GPM, P20	400394	400394			1
	Gear Pump - 10 GPM, P20			402344		1
	Gear Pump - 10 GPM, P31				402114	1

NO.	DESCRIPTION	D-10 (DAVID)	E-15 (ERNIE)	F-18 (FLOYD)	H-25 (HENRY)	QTY.
22.	Control Cable – 96”	402122	402122	402122	402122	1
	Control Cable – 72”	402121	402121	402121	402121	1
	Control Cable – 84”	402419	402419	402419	402419	1
	Control Cable – 120”	402123	402123	402123	402123	1
	Control Cable – 144”	402124	402124	402124	402124	1
	Control Cable – 180”	402125	402125	402125	402125	1
	Control Cable – 240”	402126	402126	402126	402126	1
23.	Hex Lock Nut 5/16-18	401240	401240	401240	401240	5
24.	Clamp Plate – Pedestal	225127	225127	225127	225127	1
25.	Cap Screw 5/16-18 x 1/2	402415	402415	402415	402415	2
26.	Pedestal Cover – Wescon, Tall	223397	223397	223397	223397	1
27.	Machine Screw 5/16-18 x 2 1/2	402154	402154	402154	402154	3
28.	Remote Valve Control, Center Detent	402120	402120	402120	402120	1
29.	Pedestal Bracket – Wescon, Tall	223396	223396	223396	223396	1
30.	Valve Connection Kit	402127	402127	402127	402127	1
31.	Hex Lock Nut 3/8-16	402038	402038	402038	402038	4
32.	Flat Washer 3/8	400164	400164	400164	400164	4
33.	Hex Head Cap Screw 3/8-16 x 1	400121	400121	400121	400121	4
34.	Hex Lock Nut 1/2-13	401316	401316	401316	401316	4
35.	Hex Head Cap Screw 1/2-13 x 2	400105	400105	400105	400105	4
36.	Reservoir Mounting Angle Assy	100511	100511	100511	100511	2
37.	Monarch Pump DA 3250 PSI	405287	405287	405287	N/A	1
38.	Monarch Pump SA 3250 PSI	405286	405286		N/A	1
	Monarch Pump SA 3250 PSI 20 Qt			405313	N/A	1
41.	Push Button Control – 10’	405289	405289	405289	N/A	1
	Push Button Control – 15’	405290	405290	405290	N/A	1
42.	Rubber Pad 1/4 x 3 x 5	405319	405319	405319	N/A	1
43.	Cable Tie – 33” Black	404956	404956	404956	N/A	1
44.	Adapter 1/4 NPTM x 3/4 JICM 90°	402510	402510	402510	N/A	1
45.	Breather Cap	405384	405384	405384	N/A	1
46.	Adapter 3/8 NPTM x 3/4 JICM 90° Extra Long	402509	402509	402509	N/A	1
47.	Pump Mounting Angle Assy	100174	100174	100174	N/A	2
48.	Adapter 3/4 JICF x 3/4 JICM 90°	403448	403448	403448	N/A	2
49.	Adapter 9/16 ORBM x 3/4 JICM 90°	403447	403447	403447	N/A	2
50.	Decal, Hoist Control	402129	402129	402129	402129	1

## SPECIFICATIONS

Hoist Model	Cylinder Bore	Cylinder Stroke	Cylinder Shaft	Operating Pressure	Minimum Floor Height
B-5 (BERT)	4"	15 1/4"	1 1/2"	3250 PSI	7"
C-8 (CHARLIE)	5"	15 1/4"	2"	3250 PSI	7"
D-9 (DANIEL)	5 1/2"	15 1/4"	2"	3250 PSI	7 1/2"
D-10 (DAVID)	5"	20 11/16"	2"	3250 PSI	7"
E-15 (ERNIE)	6"	20 11/16"	2"	3250 PSI	8"
F-18 (FLOYD)	6"	29 7/16"	2 1/4"	3250 PSI	9"
H-25 (HENRY)	2 - 5"	29 7/16"	2 1/4"	4000 PSI	8"

### CAPACITY FORMULA

The capacity of the LoBoy truck hoists can be calculated using the following steps.

1. Measure the distance, in inches, from the center of the rear hinge to the center of the body. Call this "A".
2. Measure the distance, in inches from the center of the rear hinge to the forward crosstube on the hoist. Call this "D". (See Figures 2, 3 & 4 for "D" dimensions for the various models.)
3. For Model B-5 (BERT), multiply "D" by 3.87.  
 For Model C-8 (CHARLIE), multiply "D" by 6.05.  
 For Model D-9 (DANIEL), multiply "D" by 7.32.  
 For Model D-10 (DAVID), multiply "D" by 6.16.  
 For Model E-15 (ERNIE), multiply "D" by 8.87.  
 For Model F-18 (FLOYD), multiply "D" by 8.75.  
 For Model H-25 (HENRY), multiply "D" by 14.95
4. Divide the result of Step 3 by "A". This is the capacity in tons for an evenly distributed load (over the whole length of the body) and includes the weight of the body.

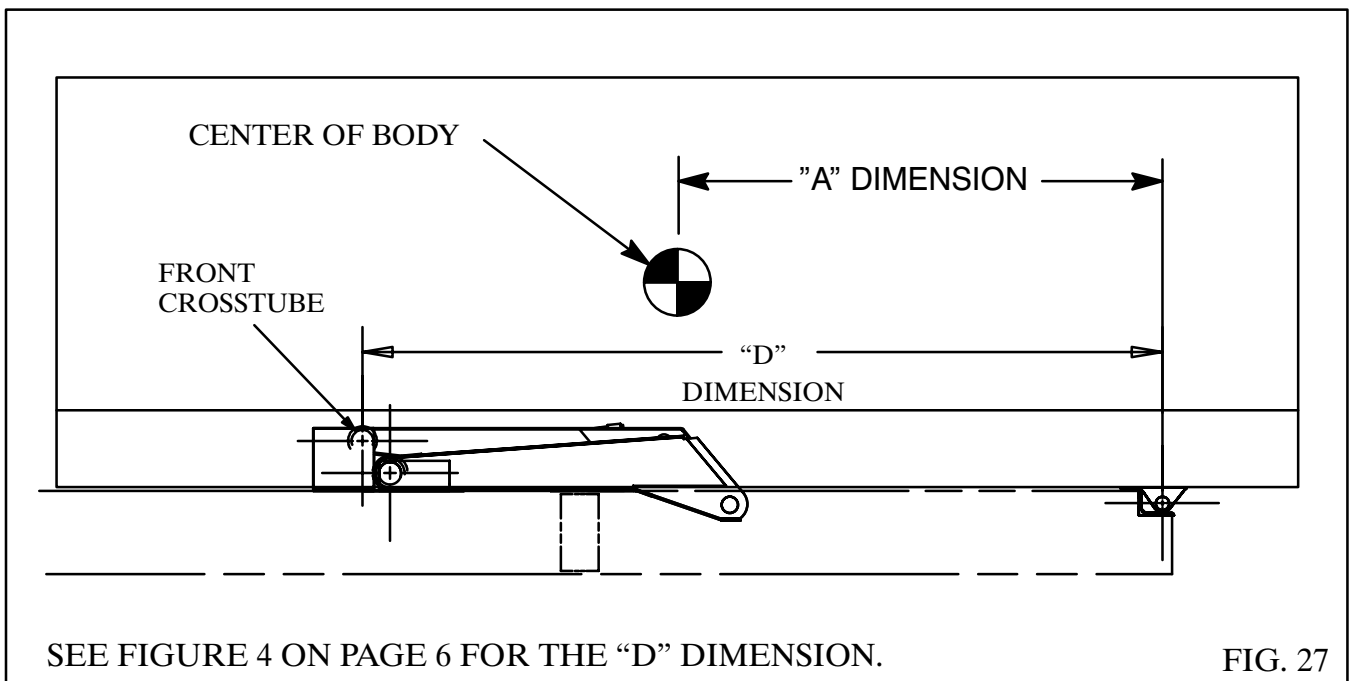

FIG. 27

## *SPECIALLY DESIGNED – WITH QUALITY IN MIND*

### **CUSTOMER SATISFACTION PLEDGE**

Crysteel's Customer Satisfaction Pledge is designed to be the most comprehensive warranty in the truck equipment industry. This pledge covers new products for a period of five (5) years, and is not restricted by vehicle mileage or when product is invoiced to our distributors. Our warranty begins when our product is put into service by the final customer.

This warranty covers our products for defective material and/or workmanship at a rate of 100 % for the first (3) years and at a rate of 50 % for years 4 and 5. This warranty covers:

- Crysteel Manufactured product
- OEM Products purchased by Crysteel as part of our product
- The repair of warranted product
- The replacement of warranted product
- Labor to replace warranted product
- Freight for replacement product
- Warranted product return freight (if required)

This warranty is limited to product supplied under the Crysteel Mfg. name and does not cover distributor modifications. Repair or replacement is at Crysteel's option. Primer warranty is limited to adherence to metal surfaces only and does not include the inside or understructure of dump bodies. Crysteel will not assume responsibility for travel, loss of use, downtime expenses or other incidental or consequential damages. This warranty is void if the product has been obviously abused or subjected to other than normal usage. There are no other warranties except as described above, and Crysteel makes no warranty of fitness for a particular purpose.

### **! CAUTION !**

- **BODY MUST BE BRACED BEFORE SERVICING HOIST OR WORKING IN AREA WITH BODY IN RAISED POSITION**
- **LUBRICATE HOIST GREASE FITTINGS OFTEN – AT LEAST EACH TIME TRUCK IS SERVICED**
- **TRUCK MUST BE LEVEL FOR DUMPING**
- **DO NOT OVERLOAD**

CRYSTEEL MFG, INC.

## **CRYSTEEL MANUFACTURING, INC.**

P.O. Box 178 52182 Ember Road  
Lake Crystal, MN 56055

1902 Route 57 South  
Fulton, NY 13069

(507) 726-2728 (800) 533-0494