

**CRYSTEEL'S**

**LO-BOY**

**LB547 & LB647**

**TRUCK HOIST**

MOUNTING AND OPERATING INSTRUCTIONS



BOX 178 / HWY 60 E LAKE CRYSTAL, MINNESOTA 56055-0178  
TELEPHONE 507-726-2728 OUT OF MN 800-533-0494

**O  
W  
N  
E  
R  
S  
  
M  
A  
N  
U  
A  
L**

**DATE PURCHASED** \_\_\_\_\_  
**HOIST SERIAL NUMBER** \_\_\_\_\_  
**CYLINDER SERIAL NUMBER** \_\_\_\_\_  
**PUMP SERIAL NUMBER** \_\_\_\_\_  
**DEALER** \_\_\_\_\_  
**ADDRESS** \_\_\_\_\_  
**PHONE** \_\_\_\_\_

### OPERATION AND USE

1. Engage PTO from cab and adjust engine speed to fast idle.
2. To raise the hoist, press down on the knob of the hoist control lever and pull the lever back. To hold the body in any position, return the hoist control lever to its center detent position. To lower the hoist, press down on the knob of the hoist control lever and push the lever forward. Return the hoist control lever to its center detent position when not in use.
3. Cycle the hoist several times to remove air from the cylinder and hydraulic lines.
4. It is advisable to run the PTO to "power down", or lower, the hoist because this will act as a hydraulic lock to hold the hoist in the lowered position. It is not necessary to do this, however, because the reservoir has sufficient capacity whether or not the hoist is powered down. You will benefit from the advantages of the double acting hoist only if you power it down.
5. To make use of the hydraulic lock feature, place the hoist control lever in the center detent position after the hoist is powered down. This places the pressure on the valve, where it belongs, not on the pump.
6. **DO NOT LEAVE THE PTO IN GEAR WHILE TRANSPORTING. THIS WILL CAUSE SEVERE DAMAGE TO THE HYDRAULIC PUMP AND/OR PTO.**
7. The hydraulic system should be drained, flushed and refilled with proper hydraulic fluid at regular intervals. **CAUTION: NEVER** use hydraulic brake fluid in the hydraulic system.

### SOME DO'S AND DON'T'S FOR SAFETY AND LONG SERVICE

1. Use the proper hydraulic fluid. **KEEP IT CLEAN.** Remember to change it regularly.
2. Lubricate all grease fittings at regular intervals.
3. **ALWAYS** carefully block up the body, using the body prop, before working under it.
4. Do not "race" the engine when operating the hoist.
5. Do not load the hoist beyond its capacity.
6. Operate the hoist on level ground only.
7. Do not drive the truck with the hoist raised, always lower the hoist.
8. **DO NOT** tamper with the hydraulic relief valve. This will void the warranty. It can cause severe damage to the hoist and cylinder.
9. Never leave the PTO in gear while transporting. It will ruin the hydraulic pump.
10. Check all bolts and set screws regularly. Keep them tight.

### FOREWORD

Crysteel's LB547 and LB647 Hoists are designed and intended for use on single-axle trucks with cab-to-axle dimensions of 60 to 144 inches and body lengths of 8 to 16 feet.

This manual contains information necessary for the proper installation and operation of Crysteel's Model LB547 and LB647 Hoists. Study it carefully before attempting to install or use the hoist. With proper installation and maintenance, your Crysteel LoBoy Hoist will give many years of trouble-free service.

When ordering parts, be sure to give the serial number of the hoist, cylinder, and pump. The serial number of the hoist is stamped into the hoist frame near the base end of the cylinder. The serial number of the cylinder is stamped on the barrel of the cylinder near the base. The serial number of the pump is found on the plate on the side of the pump. For future reference, copy these numbers *NOW* in the space provided on page 1. Order parts by number and description as given in the parts listing in this manual.

### KEEP THIS MANUAL IN A SAFE PLACE FOR FUTURE REFERENCE

### TABLE OF CONTENTS

- Purchase Record ..... 1
- Operation and Use ..... 1
- Install Rear Hinge ..... 3
- Install Hoist Pivot Pads ..... 4
- Locate Hoist ..... 4
- Install Pump ..... 5
- Install Reservoir / Valve ..... 5
- Install Hoist Control ..... 6
- Install Hoses ..... 7
- Mount Body ..... 8
- Install Body Guides ..... 9
- Install Body Props ..... 9
- Install Grease Zerks & Lubricate Hoist ..... 10
- Install Decals ..... 11
- Parts List ..... 12-16
- Specifications ..... 17
- Warranty ..... Back Page

## INSTALL REAR HINGE

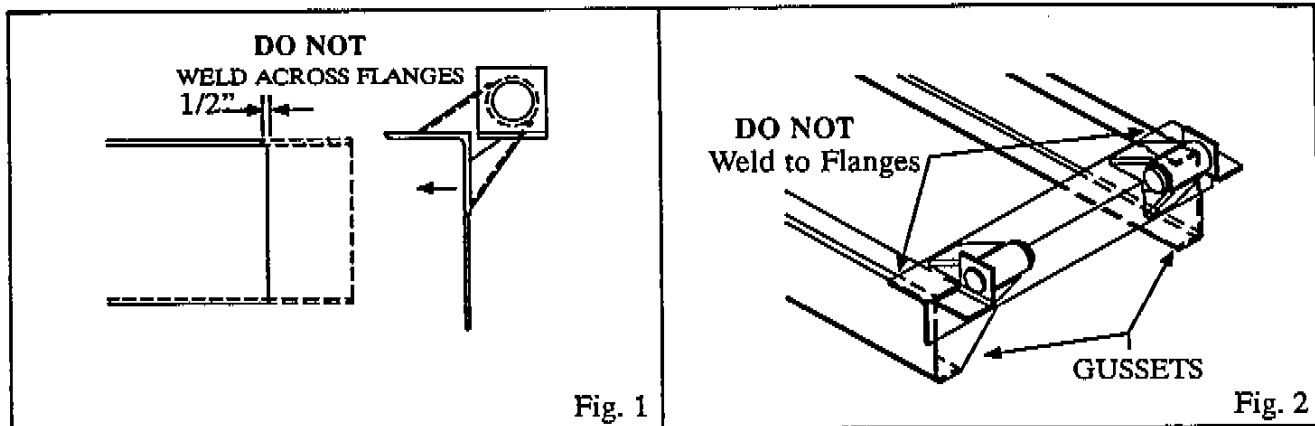

The rear hinge should be located as close behind the rear spring shackle as possible. Measure 1/2" back from the back side of the rear spring shackle and mark a vertical line on the truck frame. Cut the truck frame off as marked. Trim the top flange of the truck back 1/2" to clear the radius on the inside of the rear hinge frame angle. Place the rear hinge on the truck frame as shown in Figs. 1 and 2 and clamp it in place. Make sure the rear hinge is centered on and square with the truck frame. Securely weld the rear hinge to the truck frame. **DO NOT** weld across the flanges of the truck frame rails at the front of the rear hinge angle. Trim the bottom edge of the gusset as needed.

The rear hinge is designed to fit trucks with 34" frames; it needs to be narrowed when trucks with narrower frames are used. To make the rear hinge narrower, cut the rear hinge frame angle between the pivots as shown in Fig. 3, remove a section and weld the two halves together. Reinforce the welded joint with plates (not supplied.)

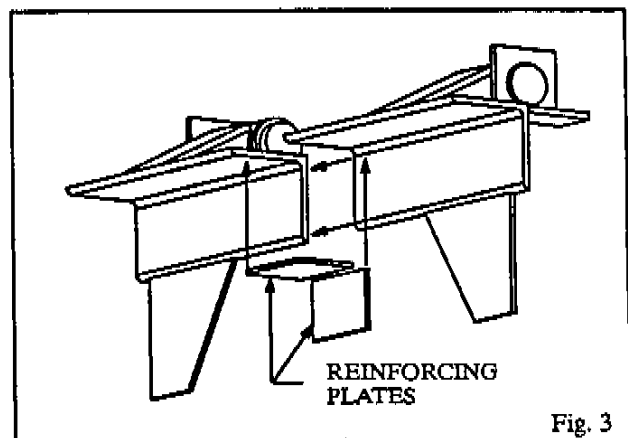

## INSTALL HOIST PIVOT PADS - LB547

The LB547 has separate hoist pivot pads to allow the hoist to be installed on trucks with narrower frames (down to 29 inches). Centering collars are supplied with these hoists to center the hoist on the truck frame. These collars and pivot pads will need to be added to the hoist frame before installing the hoist on the truck frame. Place a centering collar on the shaft of each of the hoist pivot pads and insert the hoist pivot pads into the hoist cross tubes as shown in Fig. 4. Measure the truck frame

width, subtract 5" and adjust the hoist pivot pads to fit. For example, if the truck frame measures 34", subtract 5" and set the hoist pivot pads at 29". (See Fig. 5.) Be sure the hoist is centered between the pivot pads. Securely weld the centering collars to the hoist pivot pad shafts.

NOTE: The LB647 has pre-installed hoist pivot pads.

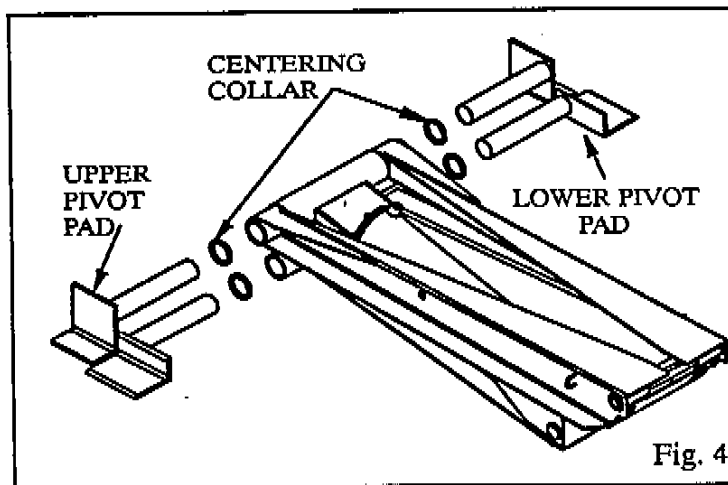

Fig. 4

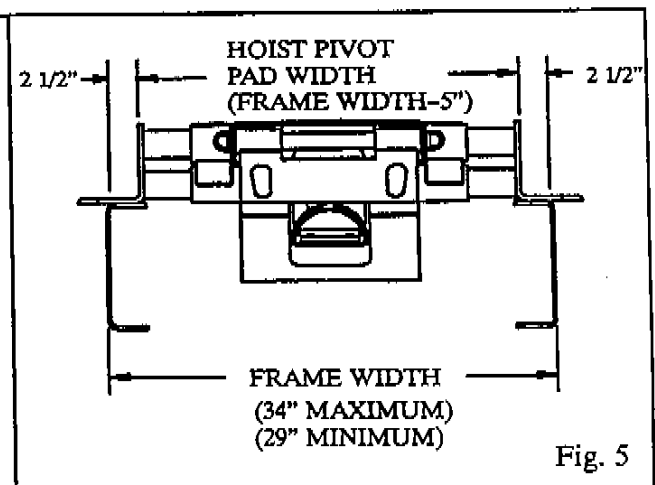

Fig. 5

## LOCATE HOIST

Determine where to mount the hoist on the truck frame. Please refer to the chart in Fig. 6 for the relationship between dump angle and "D" dimension. Measure forward from the center of the rear hinge pin and mark, on the truck frame, the location of the front cross-tube of the hoist frame. Place the hoist on the truck frame and clamp the hoist pivot pads to the truck frame. The hoist should be level with the truck frame. If the center hinge end of the hoist is too high, relocate the hoist. If the center hinge end of the hoist is too low, install spacers (not supplied) on the cross-member in the truck frame under the hoist. Make sure the hoist frame is centered on and square with the truck frame. Clamp a hoist mounting

angle to the lower hoist pivot pad and to the outside of the truck frame (one on each side) and mark the truck frame for drilling.

**CAUTION: BE CAREFUL OF BRAKELINES, WIRING, ETC. INSIDE THE TRUCK FRAME WHEN DRILLING THE TRUCK FRAME.**

Drill 21/32 diameter holes in the truck frame using the hoist mounting angles as guides. Bolt the mounting angles to the truck frame using 5/8 x 2 cap screws and hex lock nuts. Securely weld the lower hoist pivot pads to the mounting angles. Remove the clamps.

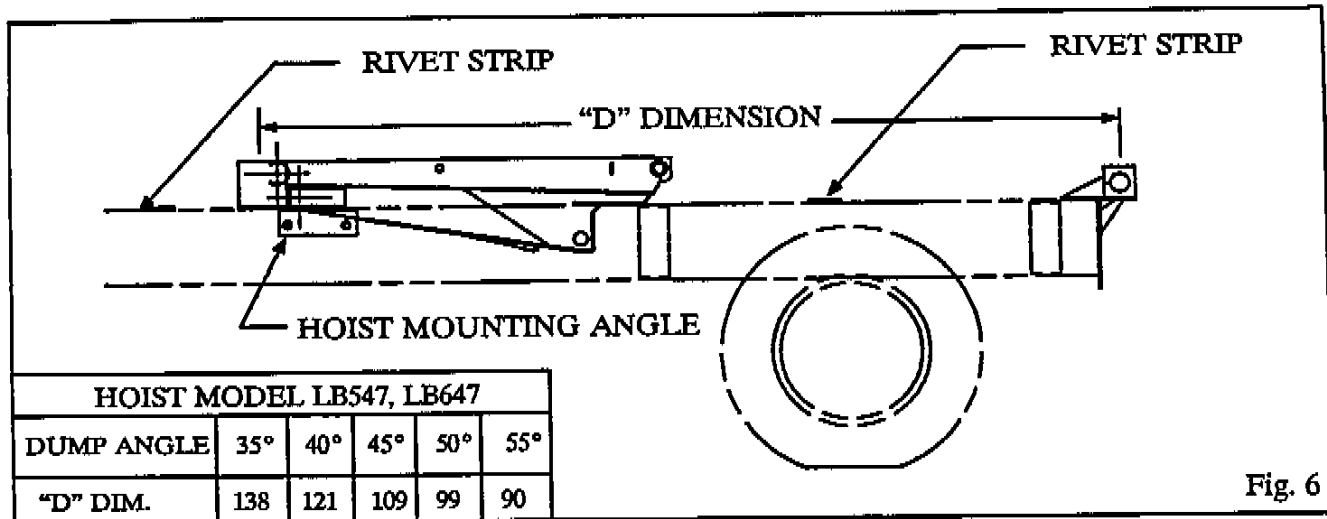

Fig. 6

### INSTALL PUMP

The gear pump has an SAE 'B' mounting configuration, a 13 tooth splined shaft and a four-bolt mounting flange, and is assembled for rotation in either direction. **NOTE:** This pump will mount directly to Chelsea's output type 'XK' or Muncie's

output type 'D'. Crysteel Manufacturing recommends a PTO ratio of 100-120%. This assures a minimum pump operating speed of 600 RPM. Bolt the gear pump to the PTO output flange using 1/2 x 1 1/4 cap screws.

### INSTALL RESERVOIR / VALVE

The reservoir/valve assembly should be mounted on the same side of the truck as the pump with the exposed end of the valve spool toward the front. Bolt the mounting angles to the reservoir/valve assembly using 3/8 x 1 cap screws, flat washers and hex lock nuts. Place the valve/reservoir assembly inside the truck frame and raise it as high as possible. See Fig. 7. (There is no drive line to align and the reservoir should be higher than the pump for reliable performance.) Make sure there is enough clearance for the truck drive line and hot exhaust pipes. **THE ENGINE EXHAUST MUST NEVER BLOW DIRECTLY ONTO THE**

**RESERVOIR/VALVE ASSEMBLY.** Clamp the mounting angles to the truck frame and mark the truck frame for drilling using the pump mounting angles as guides.

**CAUTION: BE CAREFUL OF BRAKELINES, WIRING, ETC. INSIDE THE TRUCK FRAME WHEN DRILLING THE TRUCK FRAME.**

Drill 17/32" holes in the truck frame and bolt the reservoir/valve assembly in place using 1/2 x 1 3/4 cap screws and hex lock nuts.

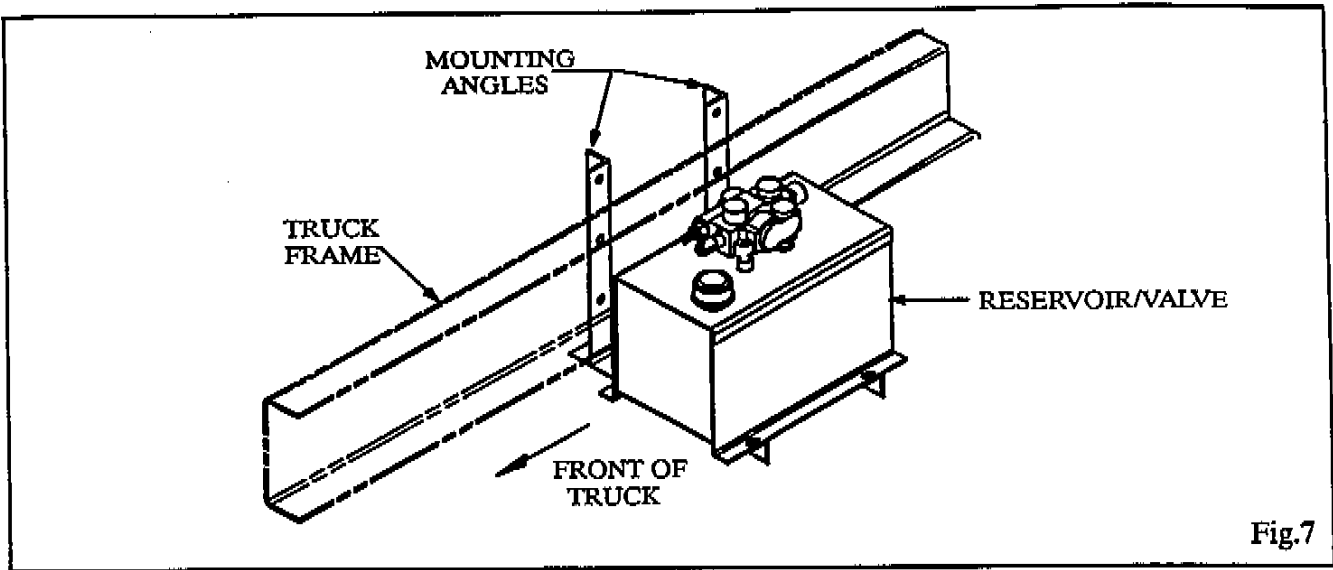

Fig.7

## INSTALL HOIST CONTROL

Mount the Hoist Control decal on the pedestal taking care to align the holes for the PTO cable and indicator light. Temporarily assemble the valve control head to the pedestal using 5/16 x 2 1/2 machine screws and hex nuts. Place this assembly on the floor of the cab. The pedestal and valve control should angle forward. This makes it convenient for the operator to pull the hoist control lever back to raise the hoist. Make sure there is enough room to operate the valve control and gear shift lever and to adjust the seat. Check below the floor for obstructions and cable routing. Relocate the valve control if necessary. Mark the floor using the pedestal as a template and drill 1 1/32" holes for the mounting screws and a 3/4" hole for the control cable. Assemble the control cable to the valve control head and assemble the valve control head and cover to the pedestal using 5/16 x 2 1/2 machine screws and hex lock nuts. Insert the control cable through the hole in the floor and mount the pedestal to the floor using 5/16 x 1/2 hex head cap screws, clamping plate (under the floor) and hex lock nuts. Make sure the valve control lever is in its center detent position. Keep the control cable away from hot exhaust pipes and rotating drive shafts. The control cable should not

have any sharp bends or kinks in it (these will make the control harder to operate).

Install the 3/4" hex jam nut onto the valve end of the control cable and turn it past the threads. Insert the end of the cable through the bonnet clamp. Install the bonnet onto the control cable and turn it past the threads also. Install the 1/4" hex jam nut and terminal eye on the core rod of the cable; lock the terminal eye to the core rod of the cable using the hex jam nut. Place the terminal eye in the slot of the valve spool; insert the short pin through the valve spool and terminal eye and secure it in place with the 'E' ring. Thread the bonnet onto the end of the cable so it firmly touches the end of the valve. (Do not over- or under-tighten the bonnet as either would move the valve spool out of its neutral position.) Remove two cap screws from opposite corners of the seal retainer plate. Slide the bonnet clamp onto the bonnet and secure it to the valve using the 1/4 x 1 1/4 cap screws, lock washers and flat washers. Lock the bonnet to the cable using the 3/4" hex jam nut. (See Fig. 8.)

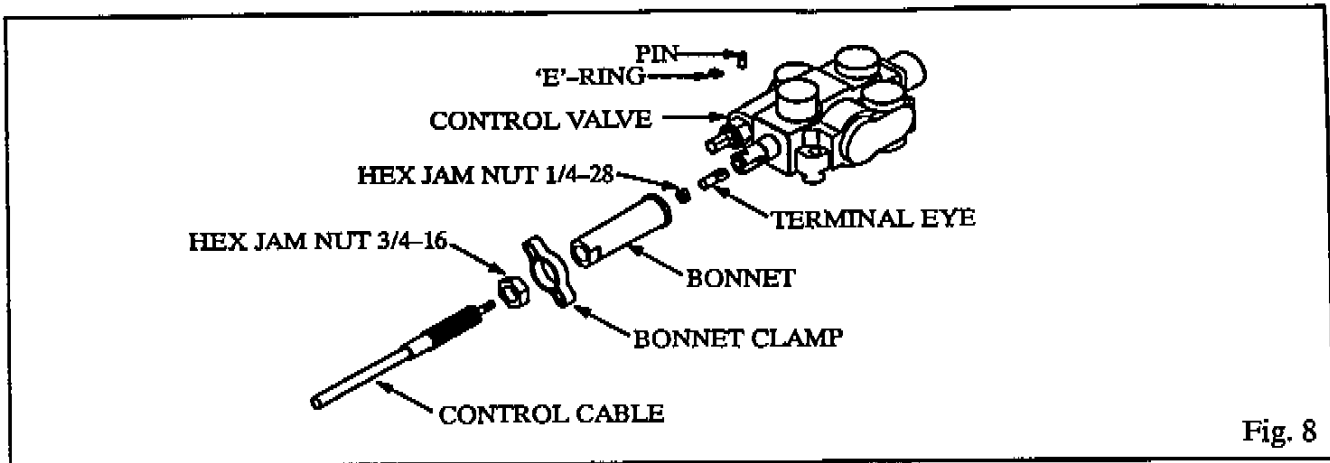

### INSTALL HOSES

Study Fig. 9 very carefully before connecting the hoses. Install a 3/4" 90° street elbow and a 3/4" hose barb in the suction port on the bottom of the reservoir. Install a 3/4" hose barb in the suction port of the pump and install the suction hose. Secure the suction hose in place using hose clamps. Install a 90° swivel adapter in the 'IN' port of the control valve and install a 3/4 x 1/2 hex reducer in the pressure port of the pump. Install a 72" long 1/2" hose from the pump to the valve.

Remove the plugs from the cylinder ports. Install 90° adapters in the cylinder ports. Connect 18" hoses from the 90° bulkhead fittings to the cylinder ports as shown in Fig. 9. Note that each hose

crosses over to the opposite side of the cylinder. Install 90° adapters in the work ports of the control valve. Connect the shorter 3/8" hose to the hydraulic hose in the hoist frame on the same side of the truck as the reservoir/valve assembly. Connect the longer 3/8" hose to the other side. Connect the hose that is connected to the base end port of the cylinder to the 'B' port on the control valve. Connect the other 3/8" hose to the 'A' port. This will raise the hoist when the control lever is pulled back and lower it when pushed forward. **NOTE:** The 'A' port is the 'power-down' port and has a pressure of only 500-1000 PSI; the 'B' port has full system pressure.

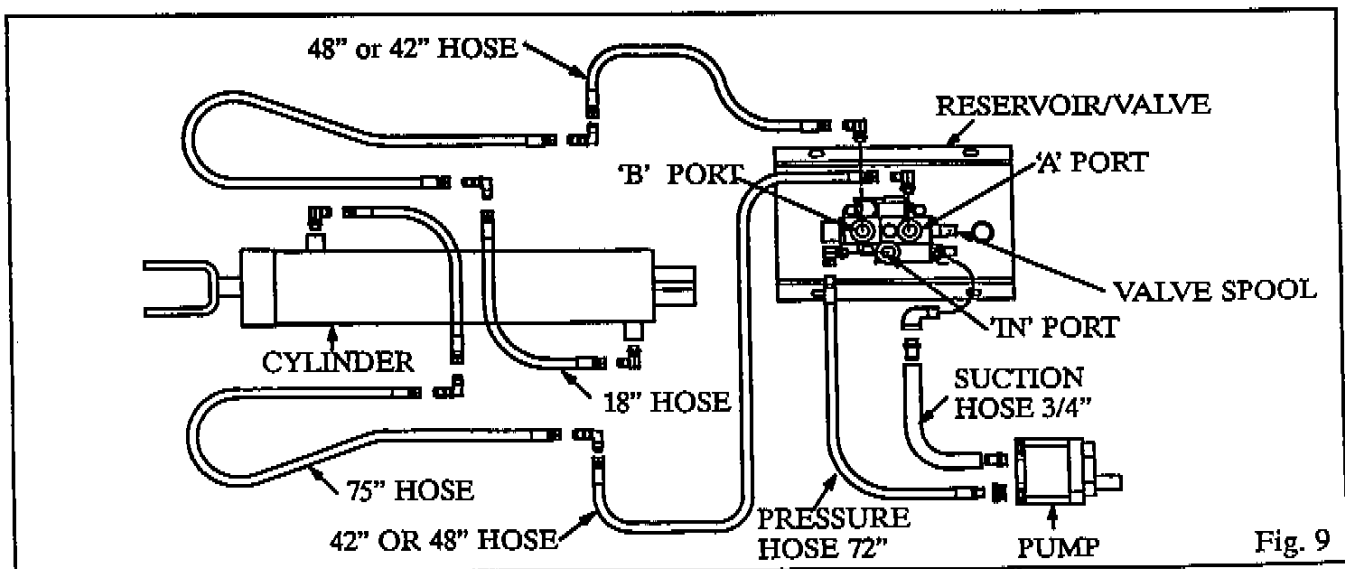



### MOUNT BODY

It is recommended that the body be painted before it is mounted on the truck. Place the body in position on the truck with three inches of clearance behind the cab. Use the rivet strip mounting pads between the longbeams and the truck frame. Use three on each side, spaced as shown in Fig. 6 on Page 5. Weld them to the longbeams. Align the body longbeams carefully with the truck frame. Securely weld the longbeams to the rear hinge brackets and to the upper hoist pivot pads. On the

inside of the longbeams, securely weld the longbeam fillers to the top of the upper hoist pivot pads and to the top flange of the longbeam channels as shown in Fig 10. Repeat this for the rear hinge pivot brackets as shown in Fig. 11. For Crysteel's new grain body, place the 9 inch square plate between the angle lift bracket and the inside of the longbeam. Securely weld this plate to the longbeam and to the upper hoist pivot pad. Be sure to do this on both sides.

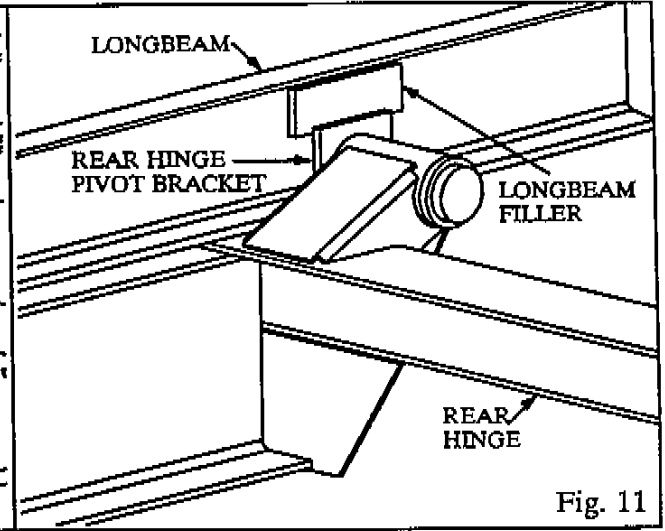
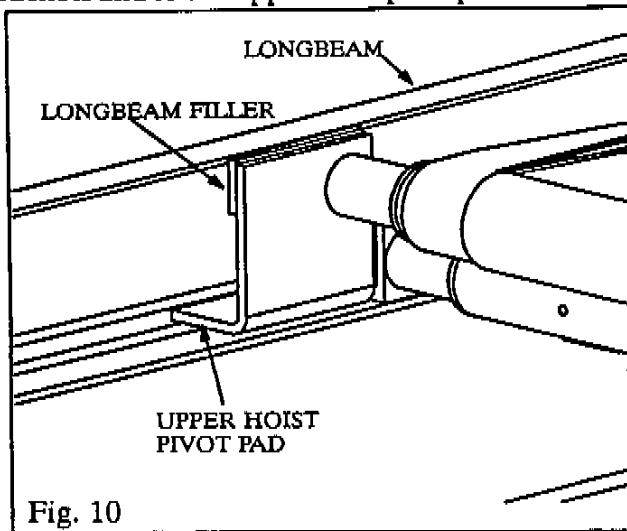

### INSTALL BODY GUIDES

The four body guides are all identical. Weld one to each longbeam as shown in Fig. 12, with the wide end of the body guide at the top and centered over the truck mounting brackets. Now weld the other pair of body guides to the truck

mounting brackets, and tight against the first body guides as shown in Fig. 13. There should be NO sideplay between body guides when the truck body is in the lowered position.

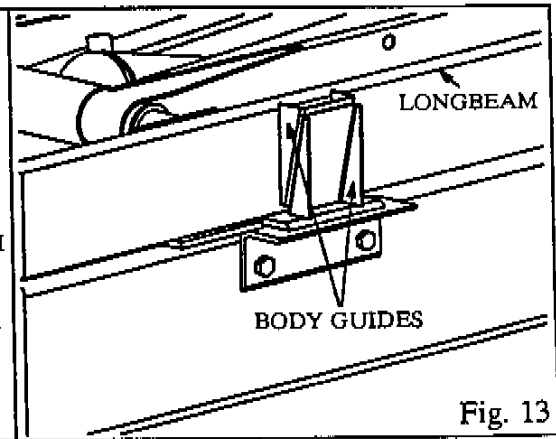
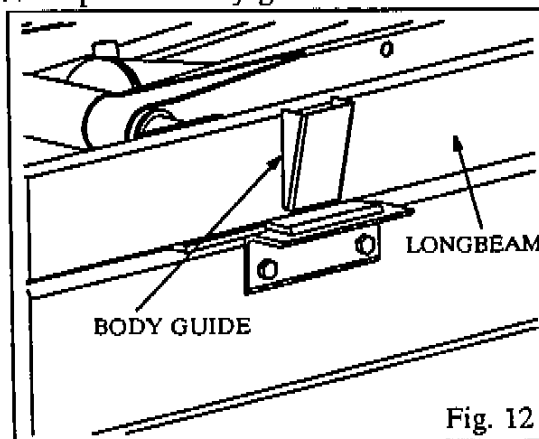

## INSTALL BODY PROP

The body prop is designed and intended to support an *EMPTY* truck body in the raised position. Using the body prop permits service work to be performed safely beneath a raised body. It is mounted on the outside of the truck frame on the drivers side.

1. Raise the body to the desired height and brace it securely before beginning installation.
  2. Raise the prop arm to a free standing position by allowing the prop arm to rest against the rear flange of the prop pivot.
  3. Place the longbeam bracket assy in the body prop saddle. Raise or lower the body as needed to position the bracket on the outside of the longbeam where it will not interfere with the body prop when it is in the stored position and the body is down. Securely weld this bracket assy to the body (See Fig. 11.)
  4. To operate the body prop, raise the body to the desired height, shut off all power, raise the prop arm to a free standing position. Lower the body slowly until the longbeam bracket contacts the prop arm saddle.
- DO NOT POWER HOIST DOWN!**
5. To place the body prop in the storage position, raise the body to clear the body prop saddle, lower the body prop to the storage position and lower the body.

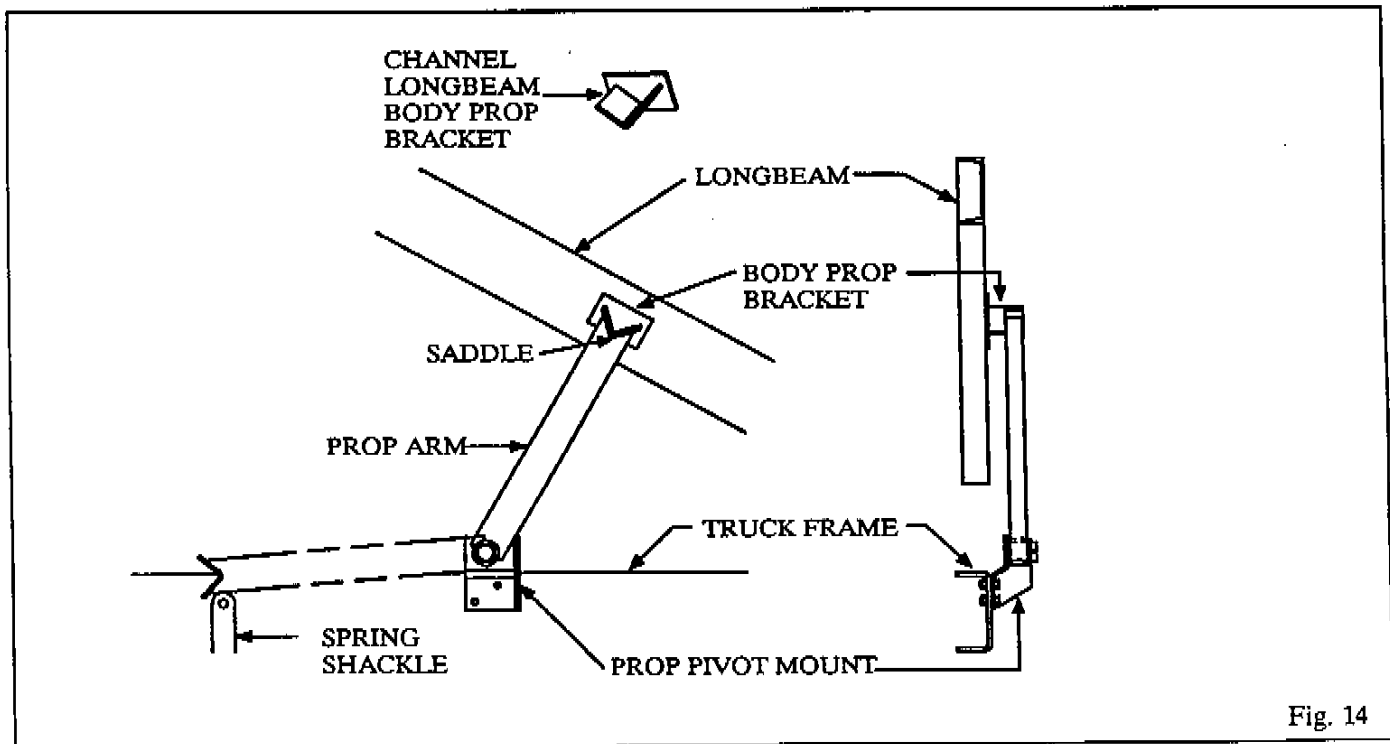

Fig. 14

### INSTALL GREASE ZERKS & LUBRICATE HOIST

Install grease zerks on the hoist and lubricate the hoist in the following locations:

- Upper Crosstube ..... 2 fittings
- Lower Crosstubes ..... 2 fittings
- Cylinder Base Pivot Tube ..... 1 fitting
- Body Prop ..... (already installed) 1 fitting
- Rear Hinge ..... (already installed) 2 fittings

Lubricate all fittings and the control cable at regular intervals, at least each time the truck chassis is lubricated. There are extremely high forces on the bearings surfaces within the hoist

frame. It pays to be generous in lubricating the hoist to insure proper operation and long life.

The center hinge and the cylinder crosshead do not need to be greased. These pivot points are equipped with self lubricating composite bearings that do not need lubrication.

ONE OF THE MOST COMMON REASONS FOR HOIST PROBLEMS IS FAILURE BY THE OPERATOR TO LUBRICATE THE HOIST.

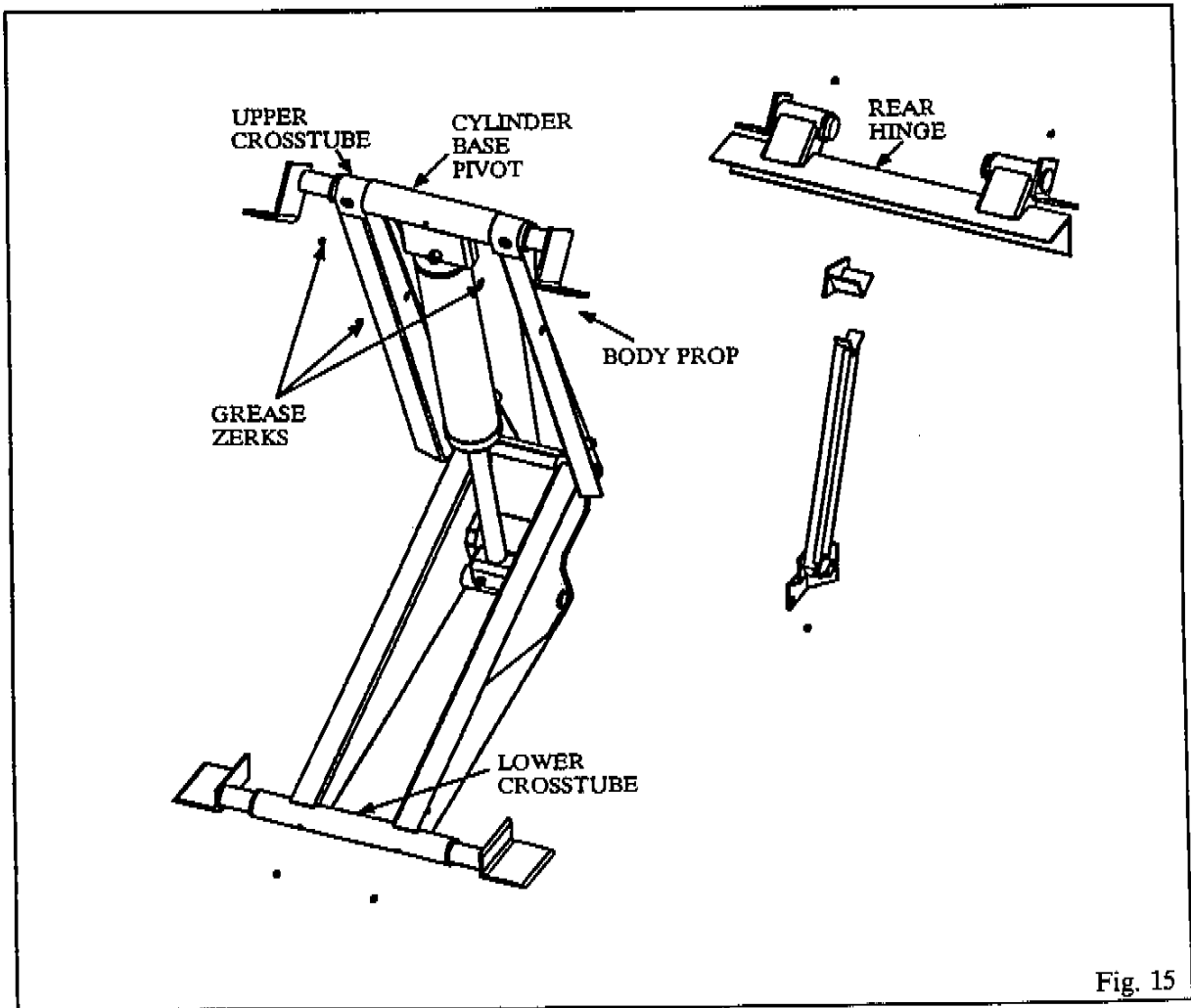

### INSTALL DECALS

After the hoist and body have been mounted, install the decals in the following locations:

1. 400640 – Mount in cab near the hoist control.
2. 400719 – Mount on the body longbeam near the body prop.
3. 400661 – Mount on the body prop arm.
4. 401576 – Mount on the out side of the body longbeam, near the front (one on each side).
5. 400643 – Mount on the body longbeam on the driver’s side.
6. 401577 – Mount in the cab in a prominent location.
7. 400642 – Mount in the cab in a prominent location.

See the following illustrations for decal identification.

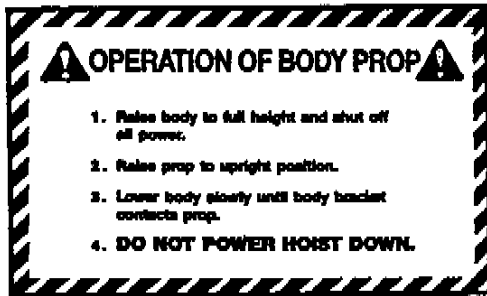

400719

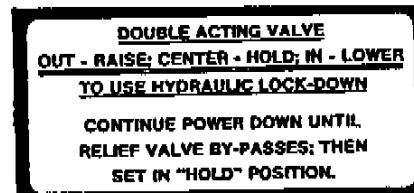

400640



401576

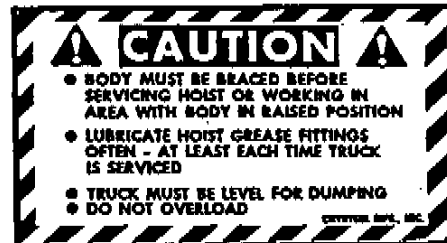

400643



401577



400642



400661

**CYLINDER PARTS LIST**

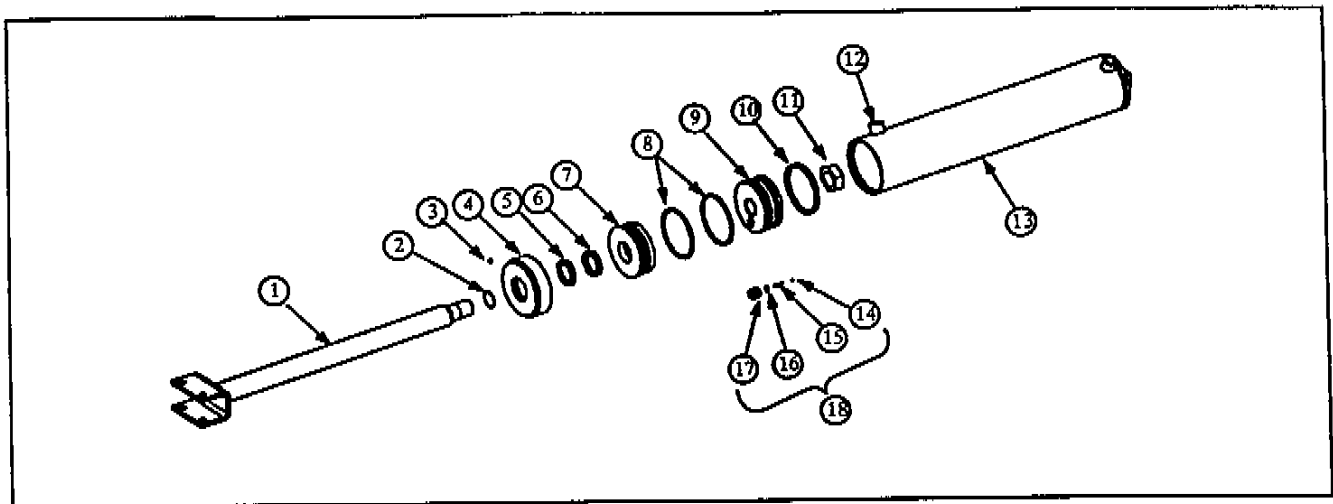

LB 547		LB647	CYLINDER PARTS LIST	
ITEM	PART NUMBER		DESCRIPTION	QTY
1.	117749	118696	Shaft Assy	1
2.	400255	400255	*O-ring 1 1/2"	1
3.	400149	400149	Set Screw 1/4 x 3/16	1
4.	104293	104299	Cylinder Cap Assy	1
5.	400913	400914	*Wiper	1
6.	400253	400907	*Polyseal	2
7.	202469	205141	Cylinder Head	1
8.	400254	400258	*O-ring	2
9.	202461	202472	Piston	1
10.	400252	400257	*Polyseal	1
11.	401370	401370	Hex Jam Nut	1
12.	401389	401389	Plug 3/4-16	2
13.	117747	119234	Outer Tube Assy	1
14.	401017	401017	O-Ring 7/16	1
15.	400013	400013	Bypass Valve Ball	1
16.	400979	400979	Bypass Valve Pin	1
17.	400978	400978	Bypass Valve Body	1
18.	105185	105185	Kit Bypass Valve (items 14-17)	
19.	107960	107962	Seal Kit (includes * items)	

### HOIST PARTS LISTS

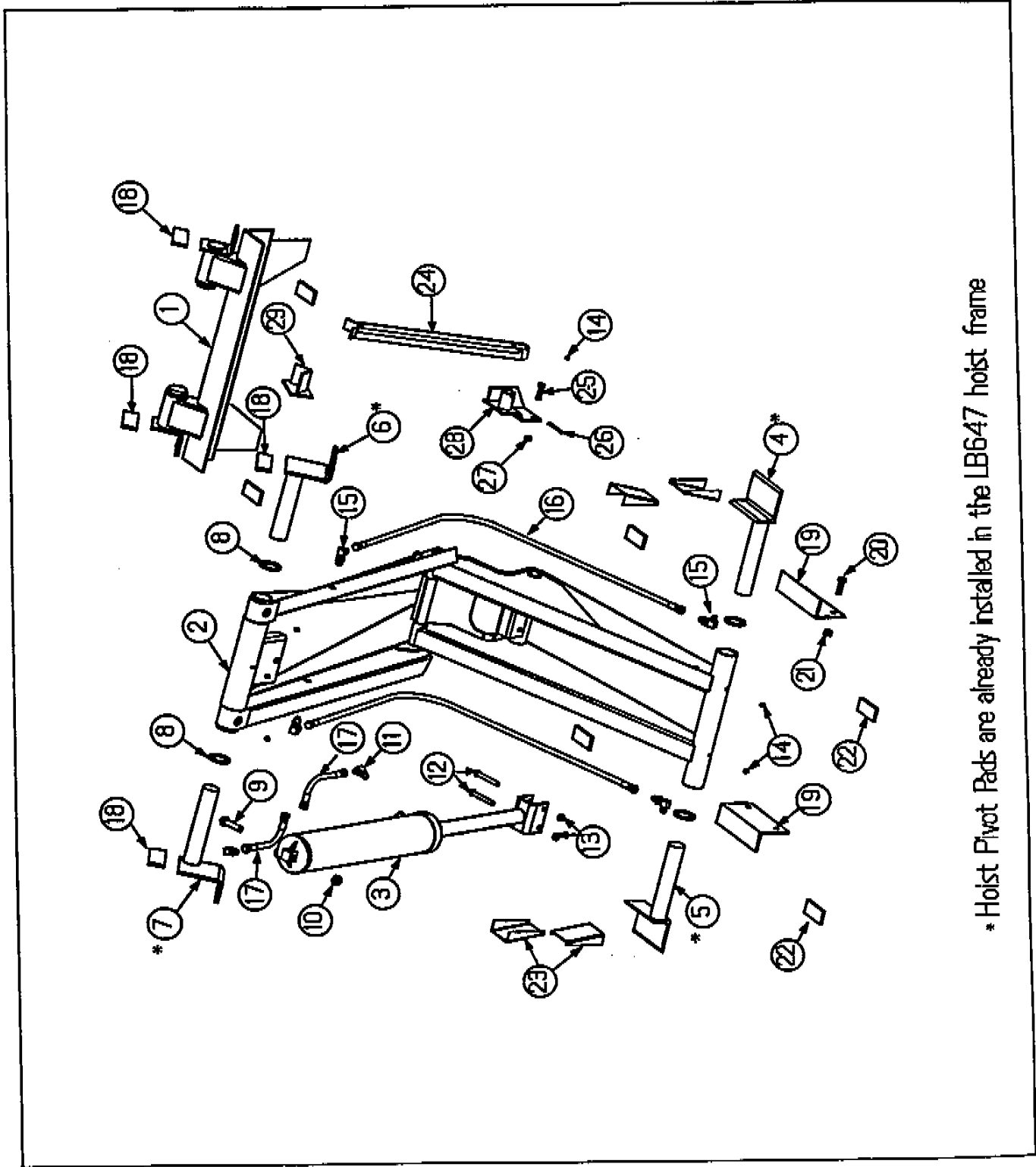

\* Hoist Pivot Pads are already installed in the LB647 hoist frame

## SERVICE PARTS FOR HOIST

	LB547	LB647		
ITEM	PART NUMBER		DESCRIPTION	QTY.
1.	118258	118258	Assy Rear Hinge	1
2.	117742	118229	Assy Frame	1
3.	117743	118230	Assy Cylinder	1
4.	117322	*	Assy Lower Pivot-L	1
5.	117323	*	Assy Lower Pivot-R	1
6.	117324	*	Assy Upper Pivot-L	1
7.	117325	*	Assy Upper Pivot-R	1
8.	224415	*	Hoist Mount Collar	4
9.	402209	402209	Screw Cap 3/4 x 2 3/4	1
10.	401226	401226	Hex Lock Nut 3/4-10	1
11.	402487	402487	Adapter 3/4ORB x 3/4 JIC 90°	2
12.	400138	400138	Screw Cap 1/2 x 3 3/4	2
13.	401316	401316	Hex Lock Nut 1/2-13	6
14.	400103	400103	Grease Zerk 1/8 NPT	8
15.	402303	402303	Adpater 3/4 JIC 90° Bulkhead	4
16.	402299	402299	Hose 3/4 JIC x 75	2
17.	402488	402488	Hose 3/4 JIC x 18	2
18.	200900	200900	Longbeam Filler (3/8 x 2 x 6)	4
19.	201422	201422	Angle, Mounting	2
20.	402374	402374	Screw Cap 5/8 x 2NC	4
21.	401582	401582	Hex Lock Nut 5/8-11	4
22.	200892	200892	Longbeam Spacer (3/8 x 2 x 4)	6
23.	201415	201415	Body Guide	4
24.	101220	101220	Body Prop Leg Assy	1
25.	400105	400105	Screw Cap 1/2 x 2	2
26.	400220	400220	Pin Spring 1/4 x 3	1
27.	401316	401316	Hex Lock Nut 1/2-13	2
28.	104190	104190	Body Prop Mount Assy	1
29.	101221	101221	Body Prop Bracket Assy	1

\*Hoist Pivot Pads are already installed in the LB647 hoist frame.

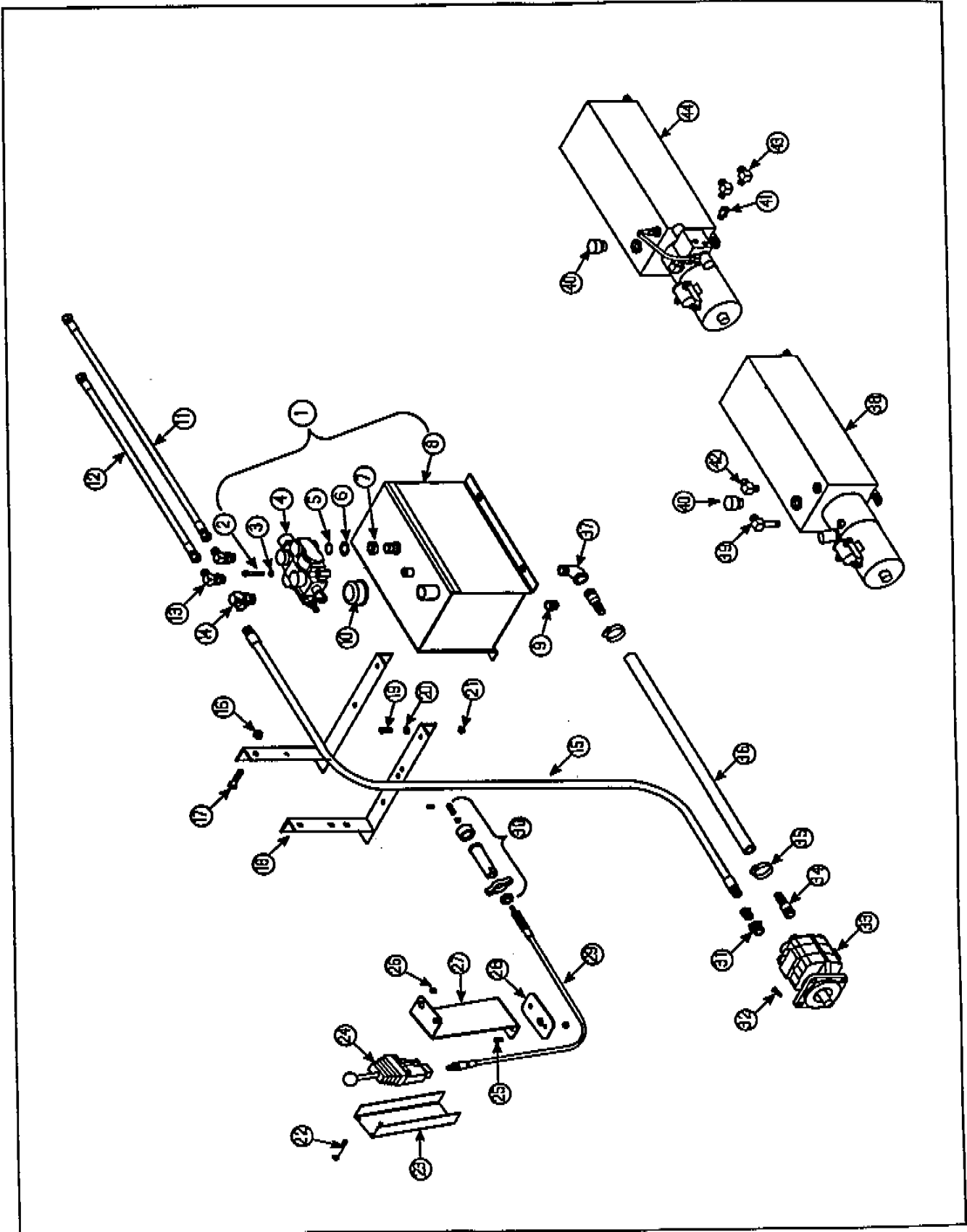



RESERVOIR PARTS			
ITEM	PART #	DESCRIPTION	QTY.
1.	116651	Reservoir/Valve Carton	1
2.	402115	Cap Screw 5/16-18 x 2NC	1
3.	400165	Lockwasher 5/16"	1
4.	402065	Control Valve	1
5.	401094	O-Ring .924 ID x .116 CS	1
6.	402093	Washer 1 1/16 Cone	1
7.	402092	Nut Hex Jam 1 1/16-12	1
8.	116361	Reservor Assy	1
9.	400405	Magnetic Pipe Plug 3/4"	1
10.	400764	Breather Cap	1
11.	402490	Hose 3/4JIC x 48 SF/SF	1
12.	402489	Hose 3/4JIC x 42 SF/SF	1
13.	402486	Adapter 7/8 ORBM x 3/4 JICM 90°	2
14.	401285	Adapter 1 1/16 ORBM x 1/2 NPT 90°	1
15.	401445	Hose 1/2 NPT x 72	1
16.	401316	Hex Lock Nut 1/2-13	4
17.	400105	Hex Head Cap Screw 1/2 x 2	4
18.	100174	Pump Angle Assy	2
19.	400121	Hex Head Cap Screw 3/8 x 1	4
20.	400164	Flat Washer 3/8"	4
21.	402038	Hex Lock Nut 3/8-16	4
22.	402154	Mach. Screw 5/16-18 x 2 1/2 RH	3
23.	223397	Pedestal Channel	1
24.	402120	Valve Control w/Center Detent	1
25.	402415	Cap Screw 5/16NC x 1/2 G2	2
26.	401240	Hex Lock Nut 5/16-18	5
27.	223396	Pedestal Bracket-Wescon	1
28.	225127	Pedestal Clamping Plate	1
29.	402122	Cable, Valve Control-96"	1
30.	402127	Valve Connection Kit	1
31.	401091	Hex Bushing 3/4 x 1/2	1
32.	400153	Screw Cap 1/2 x 1 1/4NC	4
33.	400394	Pump-Commercial 6 GPM, P20	1
34.	401447	Hose Barb 3/4NPT x 3/4	2
35.	401441	Hose Clamp 1 1/16 to 2"	2
36.	210604	Suction Hose 6' 3/4ID	1
37.	402144	Pipe Elbow 3/4 90°	1
38.	401842 (optional)	Pump, Electric-Single Acting, P/B	1
39.	402509	Adapter 3/4 JICM x 1/4 NPTF, Extra Long 90°	1
40.	400776	Breather Cap, Elec.	1
41.	402510	Adapter 1/4 NPTM x 1/4 NPTF	1
42.	402511	Adapter 3/4 JICM x 1/4 NPTF 90°	2
44.	401426 (optional)	Pump, Electric-Double Acting, P/B	1

**SPECIFICATIONS**

NTEA Class	Hoist Model	Cylinder Bore-Stroke-Shaft	Operating Pressure	Mounting Height	Minimum Longbeam Height	Body Length
D	LB547	5"-22 5/8"-2"	3250 PSI	6 1/4"	6"	9'-15'
E	LB647	6"-22 5/8"-2 1/4"	3250 PSI	6 1/4"	6"	10'-16'

**CAPACITY CHART**

HOIST MODEL								
Body Length	Cab-to-Axle	Overhang	LB547			LB647		
			40°	45°	50°	40°	45°	50°
9'	60"	18"	21.4	19.2	17.4	N/A	N/A	N/A
	72"	6"	16.1	14.4	13.0	N/A	N/A	N/A
10'	72"	18"	18.4	16.5	14.9	26.5	23.7	21.4
	84"	6"	14.3	12.8	11.6	20.6	18.5	16.7
12'	84"	30"	18.4	16.5	14.9	26.5	23.7	21.4
	96"	18"	14.3	12.8	11.6	20.6	18.5	16.7
	108"	6"	11.7	10.5	9.4	16.8	15.1	13.6
14'	108"	30"	14.3	12.8	11.6	20.6	18.5	16.7
	120"	18"	11.7	10.5	9.4	16.8	15.1	13.6
	132"	6"	9.9	8.8	8.0	14.2	12.8	11.5
15'	120"	30"	12.8	11.5	10.4	18.5	16.6	15.0
	132"	18"	10.7	9.6	8.7	15.4	13.8	12.5
	144"	6"	9.2	8.2	7.4	13.2	11.8	10.7
16'	132"	30"	N/A	N/A	N/A	16.8	15.1	13.6
	144"	18"	N/A	N/A	N/A	14.2	12.8	11.5

NOTE: Capacity is based on water-level load and includes body weight.

**CAPACITY FORMULA**

To calculate the capacity of the LB547 or the LB647 hoist for applications not shown in the capacity chart, use the following formula:

1. Measure the distance in inches from the center of the rear hinge pin to the center of the body. Call this dimension "A".
2. Measure the distance in inches from the center of the rear hinge pin to the center of the front hoist pivot, (See Fig. 6 on page 5.) Call this dimension "D".
3. For the LB547: multiply "D" by 12.7 and divide by "A".  
For the LB647: multiply "D" by 18.3 and divide by "A".
4. The result is the water-level load capacity in thousands of pounds and includes the body weight.

**- NOTES -**

---

*SPECIALLY DESIGNED – WITH QUALITY IN MIND*

**WARRANTY**

- Crysteel Manufacturing, Inc. warrants its products for a period of one year from date of purchase.
- The warranty provides that our products must perform satisfactorily or we will repair, replace or refund the purchase price at the option of the purchaser. Hydraulic pumps, valves, hoses and other purchased parts are covered by the warranties of their respective manufacturers.
- Any parts returned to Crysteel Manufacturing, Inc. shall be shipped pre-paid, and will be returned F.O.B. Lake Crystal, Minnesota.
- We will not assume responsibility for shipping, labor or travel expenses.
- The warranty is void if the product has been obviously abused, or subjected to other than normal usage.
- We reserve the right to make improvements without notice or obligation regarding models previously sold.

**! CAUTION !**

- BODY MUST BE BRACED BEFORE SERVICING HOIST OR WORKING IN AREA WITH BODY IN RAISED POSITION
- LUBRICATE HOIST GREASE FITTINGS OFTEN - AT LEAST EACH TIME TRUCK IS SERVICED
- TRUCK MUST BE LEVEL FOR DUMPING
- DO NOT OVERLOAD

CRYSTEEL MFG, INC.

**CRYSTEEL MANUFACTURING, INC.**

P.O. BOX 178 LAKE CRYSTAL, MN 56055-0178

---

# LOBOY HOIST PROFILES MODELS LB547 & LB647

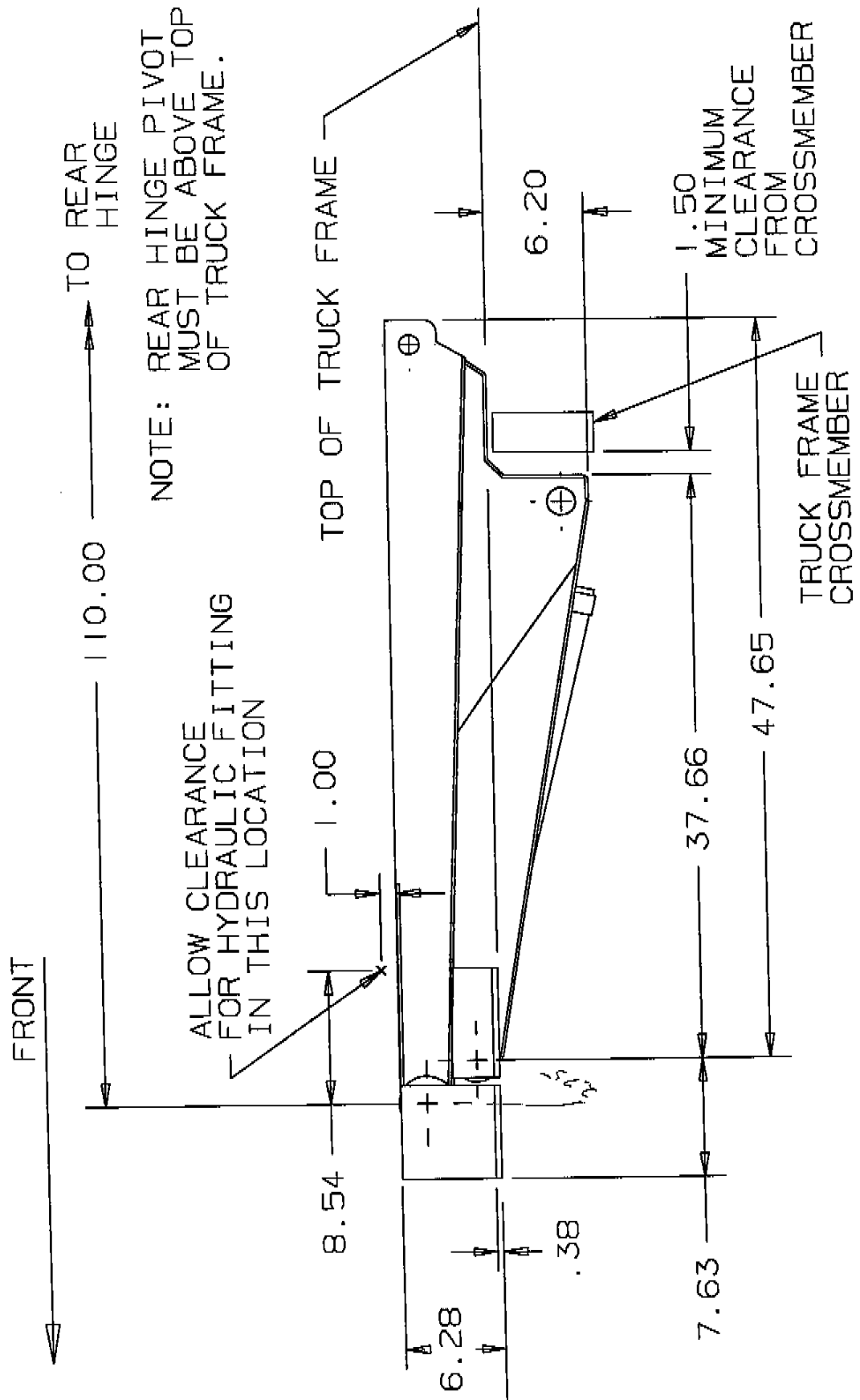

LOBOY HOIST PROFILES  
MODELS LB547 & LB647

