



Subsidiary of Federal Signal Corporation

INSTALLATION AND OPERATION MANUAL

LBS-SERIES HOIST

2465414A

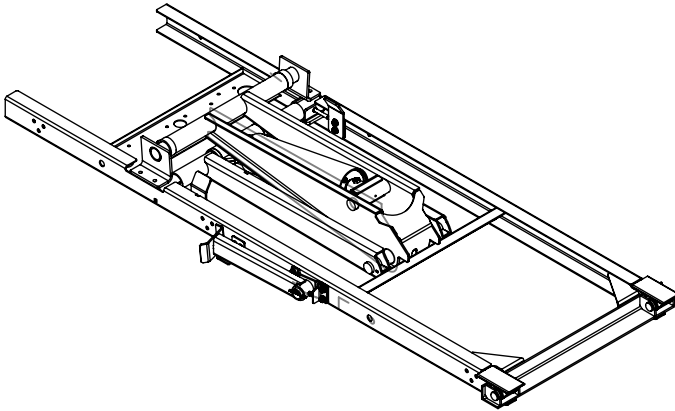

Serial Number: _____

In-Service Date: _____

Read this manual thoroughly prior to installation and operation. This manual outlines the installation and operation of an LBS Series Hoist & Sub-frame manufactured by Crysteel Manufacturing Inc. This manual should be kept readily accessible for any potential operator at all times.

Contact your dealer or a Crysteel Manufacturing customer service representative at 800-533-0494 or www.crysteel.com with any questions or concerns.

Table of Contents

Section 1: Safety	3
Section 2: Introduction	8
Serial Number	8
Specifications.....	8
Capacity Charts	9
Torque Chart	10
Section 3: Installation	11
Hoist and Sub-frame Assembly.....	11
Hoist and Sub-frame Installation	12
Hydraulic Systems.....	17
Installing the Gear Pump	17
Mounting the Reservoir/Valve Assembly	18
Installing the Hoist Control.....	19
Installing Hoses.....	21
Electric Pump Mounting	22
Installing Single-Acting Electric Pumps.....	24
Installing Double-Acting Electric Pumps	25
Adding Hydraulic Fluid.....	26
Installing the Tipper Body	27
Installing Other Bodies	28
Section 4: Decal Locations	29
Section 5: Operation	30
Raising the Prop Body	30
Lowering the Prop Body	30
Section 6: Maintenance	31
Section 7: Exploded Views	32
LBS-516 Model	32

Section 1: Safety

This manual provides guidelines and instructions for correctly operating and maintaining your Crysteel Manufacturing Inc. product. Any and all people that own and operate a Crysteel Manufacturing dump body are recommended to read and fully understand each section in this manual.

Throughout this manual, the three following types of labels will be used: Danger, Warning, and Caution. For the safety of the operator, it is imperative that all labels are obeyed.

 DANGER
Indicates imminent danger. Failure to follow this instruction will result in death or serious injury.

 WARNING
Indicates a possibly impending danger. Failure to follow this instruction can result in death or serious injury.

 CAUTION
Indicates a hazardous situation or unsafe practice which, if not avoided, could result in injury or component damage.

In all cases, Crysteel products are sold with the understanding that the purchaser agrees to thoroughly train all operating and maintenance personnel in the correct and safe installation and operation of hoist equipment and to provide adequate supervision of personnel at all times.

Read the following in its entirety before connecting, operating or repairing equipment. Purchasers and operators also should be familiar with the current version of any applicable OSHA regulations, standards and guidelines.

Should any questions arise concerning safe and proper procedures, contact Crysteel Manufacturing Inc. to the installation or use at 800-533-0494 or 507-726-2728.

The hydraulic system supplied with an LBS-Series hoist manufactured by Crysteel Manufacturing Inc. is made up of components (pump, valves, reservoir, hoses, cylinder, etc.) designed to be compatible with each other. Several different types of pump and hydraulic components are available to power the LBS-Series hoists. Refer to the pump and hydraulic component Installation and Operation Manual for more information.

 **DANGER**

If the hydraulic system used to power the hoist was supplied by TBEI, an operation manual will be included with the hydraulic components. This manual **MUST BE** available for reference by the operator when needed.

If the hydraulic system used to power the hoist was supplied by a company other than TBEI, an operation manual will be included with the hydraulic components. This manual **MUST BE** available for reference by the operator when needed.

 **DANGER**

It is the installer's responsibility to ensure any substituted components are compatible with Crysteel Manufacturing Inc. components. Incompatible hydraulic components may cause failure of the hoist, which in turn, could damage the vehicle, damage other property, and cause death or injury.

If hydraulic components are substituted, it is the installer's responsibility to be sure they are compatible with the components supplied by Crysteel Manufacturing Inc. Incompatible hydraulic components may cause failure of the hoist which in turn could damage the truck, damage other property, and cause human injury or death. Crysteel Manufacturing Company's liability and warranty for a given hoist will be voided if it is determined by Crysteel Manufacturing Inc. that substituted hydraulic components were used that were incompatible with those supplied by Crysteel Manufacturing Inc.

 **DANGER**

Welding, oxy-fuel cutting, or grinding sparks can cause fuel to ignite which in turn can lead to injury or death. Always take adequate steps to avoid ignition of fuel tanks during equipment installation.

 **DANGER**

Not installing or operating equipment correctly can cause component damage or an accident which may cause injury or death. ALWAYS install and operate equipment in accordance with manufacturer's instructions. Read and understand this manual fully before proceeding.

 **DANGER**

Damage to brake lines during equipment installation, or installing bolts or equipment in such a way that the line will rub and become damaged can lead to brake failure which can cause an accident and can lead to severe injury or death. ALWAYS take adequate steps to prevent brake line damage during installation and isolate brake lines from installed equipment.

 **DANGER**

Malfunctioning equipment can cause property damage, injury or death. ALWAYS have faulty equipment repaired before continuing its use. If required, consult the manufacturer.

 **CAUTION**

To prevent damage to the truck's electrical system, disconnect the positive battery cable and alternator when arc welding on the truck.

 **DANGER**

The inadvertent shorting of the truck's electrical supply can cause a fire or equipment damage that could lead to injury or death. **ALWAYS** disconnect the vehicle battery prior to installing, servicing or repairing the pump.

 **DANGER**

NEVER install a cable on a truck while the body is raised without first blocking, bracing, or propping the body up to prevent the body from inadvertently falling when the control valve lever is moved. A falling body will result in serious injury or death if the control valve lever is moved while someone is under the non-supported body.

 **DANGER**

NEVER exceed the gross vehicle weight (GVW) or gross axle weight (GAW) rating of your vehicle. This may result in component damage, injury or death.

 **DANGER**

Avoid bouncing or jerking of the hoist. This may result in component failure, injury or death.

 **DANGER**

NEVER raise or drive a raised body against another object. This may result in property damage, injury or death.

 **DANGER**

NEVER connect the hoist to a hydraulic system with more pressure (psi) or flow (gpm) than is recommended. This may result in component failure, injury or death.

 **CAUTION**

Unlatch tailgate prior to elevating a loaded dump body as excessive forces on the rear of the dump body may result in component failure.

 **DANGER**

NEVER operate the hoist until bystanders are free & clear of the hoist and body. This may result in injury or death.

 **DANGER**

NEVER position yourself or allow others under a raised body as this can result in serious injury or death should the body inadvertently descend. ALWAYS prop up the **unloaded** body using the body props.

 **DANGER**

Place a complete hoist operation manual in the glove box of the truck that will pull the trailer OR in a place on the trailer that is sheltered from the weather and other elements. This manual **MUST BE** available for reference by the operator when needed.

Section 2: Introduction

Serial Number

This information is required for any warranty or service inquiries, and should be recorded on the front cover of this manual for easy reference. The serial number is located on the hoist serial number plate. Figure 1.

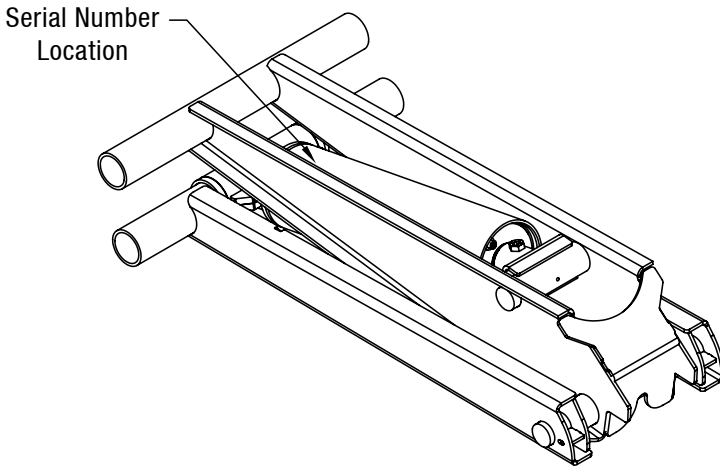

Figure 1: Serial Number Location

Specifications

Model	Hydraulic Flow Rate (gpm)	Maximum	
		Pressure (PSI)	Down Pressure (PSI)
LBS-516	4-6	3250	1000



Capacity Charts

The following charts are to be used as a reference when determining capacity based on overhang.

LBS-516			
Body Length (feet)	CA (inches)	Rear Overhang (inches)	Capacity 50° Dump (tons)
8	60	6	12.1
9	60	6	10.6
9	60	18	14.1
10	84	6	9.4
11	84	6	8.5
11	84	18	10.5
12	84	18	9.4
12	84	30	12.1
12	108	6	7.7
14	108	18	7.7
Mounting Height			9.75"
Minimum Longsill Height			7"
Mounting Distance			72.25"

Torque Chart

The following chart is to be used as a guide during installation.

Size	Grade 2 (lb-ft)	Grade 5 (lb-ft)	Grade 8 (lb-ft)
			
1/4-20	3-4	6-7	10-11
1/4-28	4-5	8-9	11-12
5/16-18	8-9	14-15	21-22
5/16-24	9-10	15-16	21-22
3/8-16	17-18	24-26	37-40
3/8-24	19-20	28-30	40-43
1/2-13	38-42	60-65	90-100
1/2-20	43-47	70-75	95-105
5/8-11	75-80	122-130	180-190
5/8-18	85-90	145-150	200-210
3/4-10	132-140	220-230	315-330
3/4-16	152-160	250-260	355-370

The following abbreviations are used in describing hydraulic fittings:

Acronym	Description
ORBM	O-ring Boss - Male Thread
NPTM	Pipe - Male Thread
NPTF	Pipe- Female Thread
JICM	JIC 37° - Male Thread
JICF	JIC 37° - Female Thread

Section 3: Installation

Hoist and Sub-frame Assembly

A full breakdown of the hoist and sub-frame components can be found in the Exploded Views section of this manual page 32.

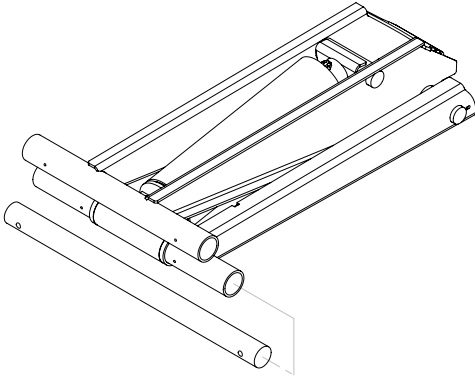

Figure 2: Saddle Tube Location

1. Slide the saddle shaft into the lower tube of the hoist so that approximately 4 inches extend past the tube on each side. (Figure 2)

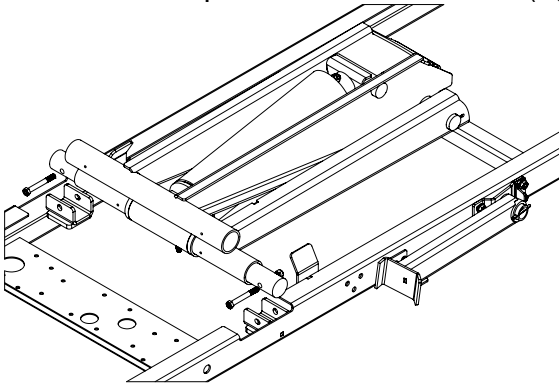
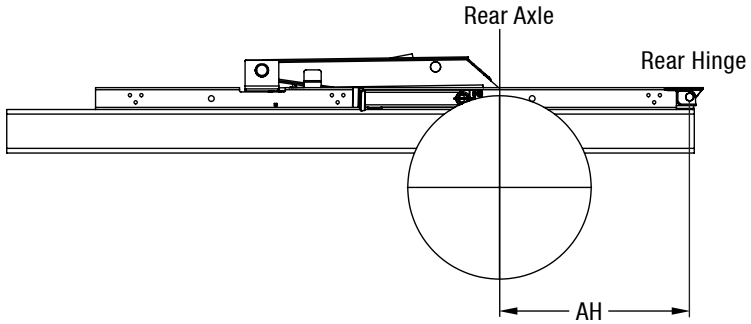

Figure 3: Sub-frame Positioning

2. Position the hoist into the sub-frame by aligning each end of the saddle shaft into the sub-frame brackets. Then secure the saddle shaft to the sub-frame with the provided hardware as shown in Figure 3. Refer to page 10 for torque guidelines.

Hoist and Sub-frame Installation



Axle to Rear Hinge (AH)*	Application
34"	Standard
46"	Ford (with rear fuel tank)
49"	Chevrolet and Dodge (with rear fuel tank)

* Approximate dimensions

Figure 4: Hoist Position

1. Position the assembled hoist and sub-frame onto the truck frame using the application chart shown in Figure 4.

NOTE: Optional 10 gauge rivet spacers may be positioned under the mounting angle and the rear hinge angle to clear rivets on the truck frame.



DANGER

Welding, oxy-fuel cutting, or grinding sparks can cause fuel to ignite which in turn can lead to injury or death. Always take adequate steps to avoid ignition of fuel tanks during equipment installation.

⚠ DANGER

Exhaust system heat can cause hydraulic component failure and may lead to a fire which could cause injury or death. Always install equipment in locations where heat from the exhaust system will not damage any hydraulic components.

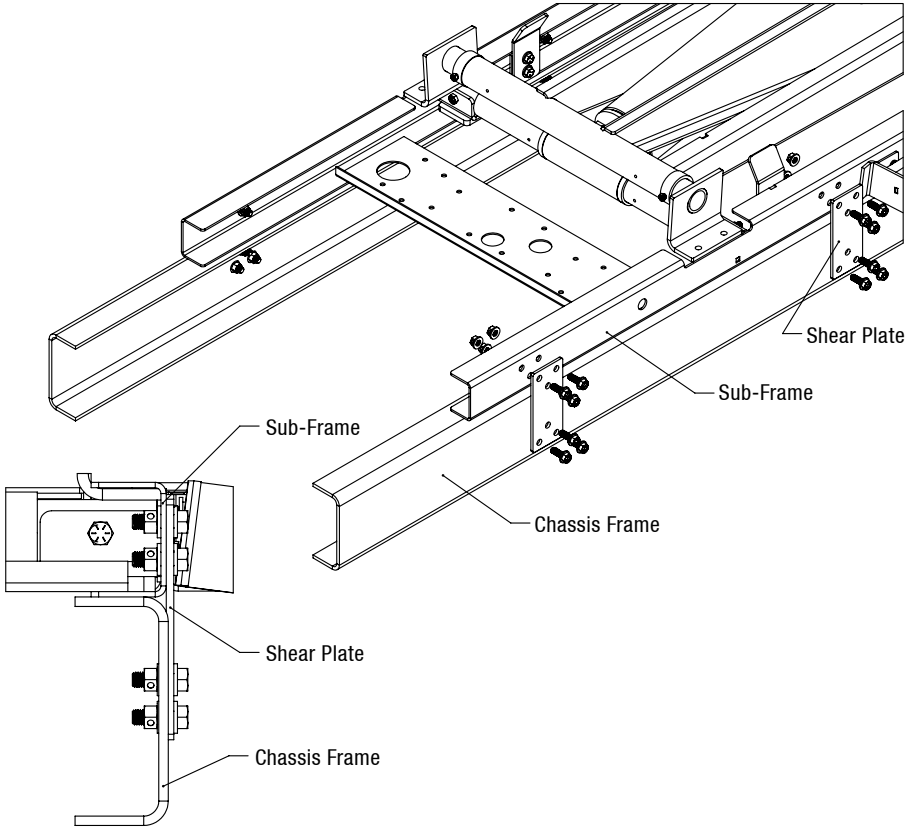

Figure 5: Sub-frame Mounting

2. Secure each mounting plate to the truck frame by drilling three 17/32" diameter holes and bolting the mounting plate to the truck frame using three 1/2" GR8 bolts and locknuts. (Figure 5). This applies to each mounting plate.
3. Bolt each mounting plate to the sub-frame rail using three 1/2" GR8 bolts and locknuts (or weld plate to subframe if necessary), keeping within the guidelines shown in Figure 5. **DO NOT** weld the mounting plates to the chassis frame. This applies to each mounting plate.

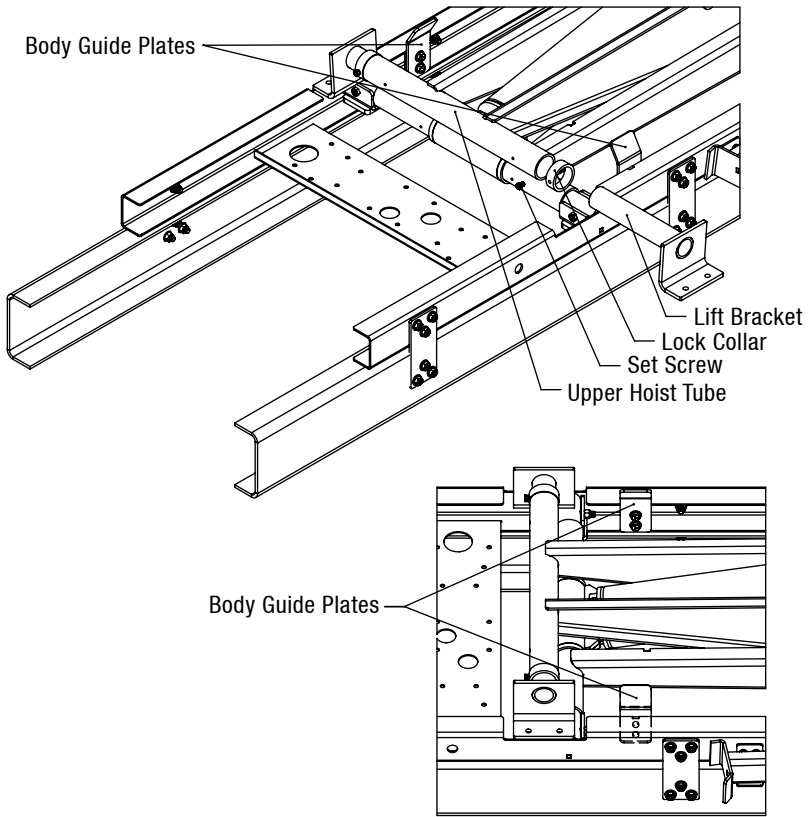

Figure 6: Lift Shaft Installation

4. Slide a lock collar onto each lifting shaft, and then slide the shafts into each end of the upper hoist tube (Figure 6).
5. Install a body guide plate onto each sub-frame rail using a set of bolt holes provided. Fasten guides using the supplied hardware (Figure 6).

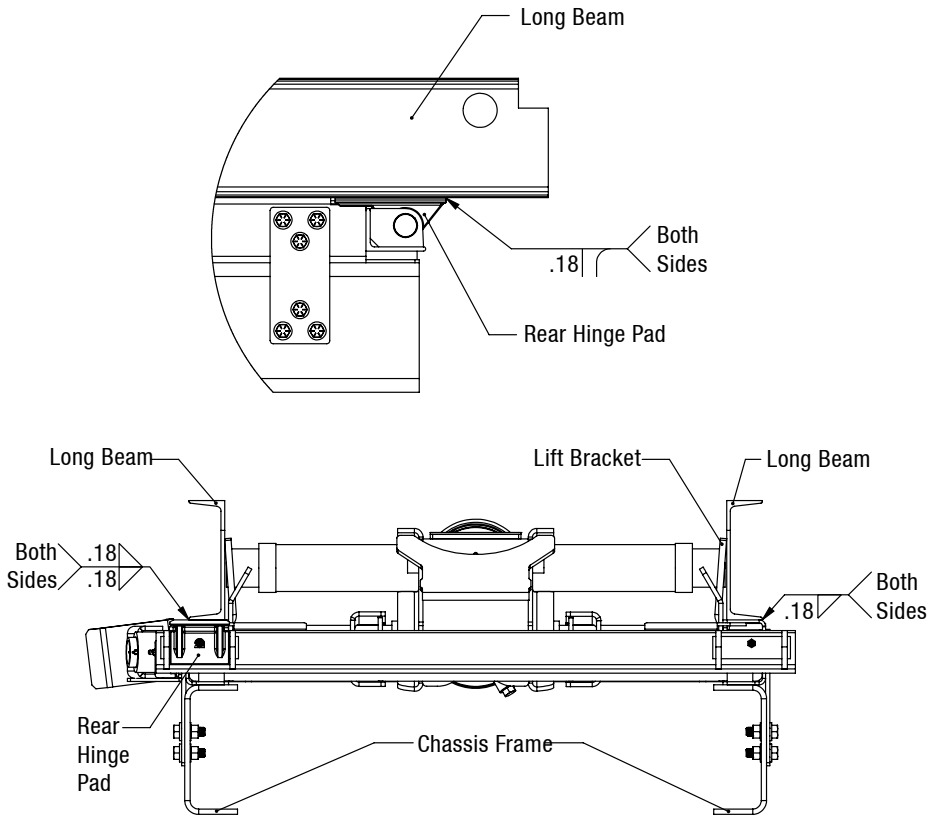

Figure 7: Body to Sub-frame Installation

6. Position the rear hinge brackets against the bottom side of the long beams. Once in position, weld the rear hinge brackets to the body long beams as shown in Figure 7.
7. Slide each lift bracket against the inside of the long beam channel. Then weld the lift bracket to the outside of the long beam (Figure 7).
8. With the lift bracket secured, slide the lock collars against the hoist lifting tube and lock them in place by tightening the 3/8" set screw.

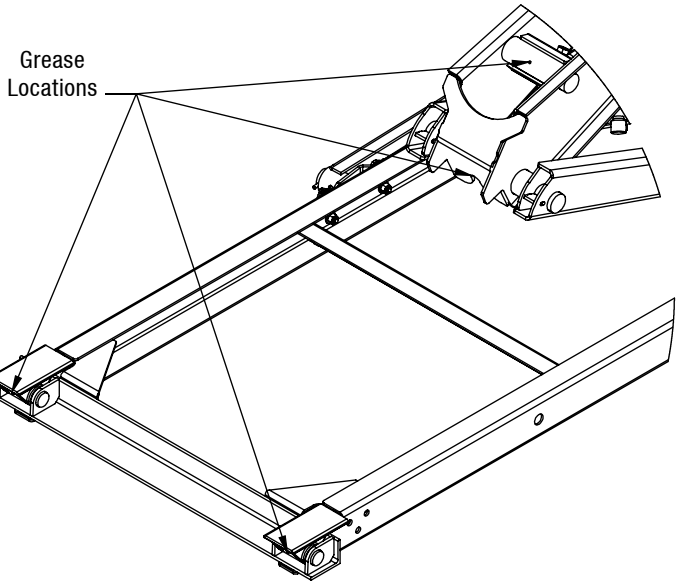
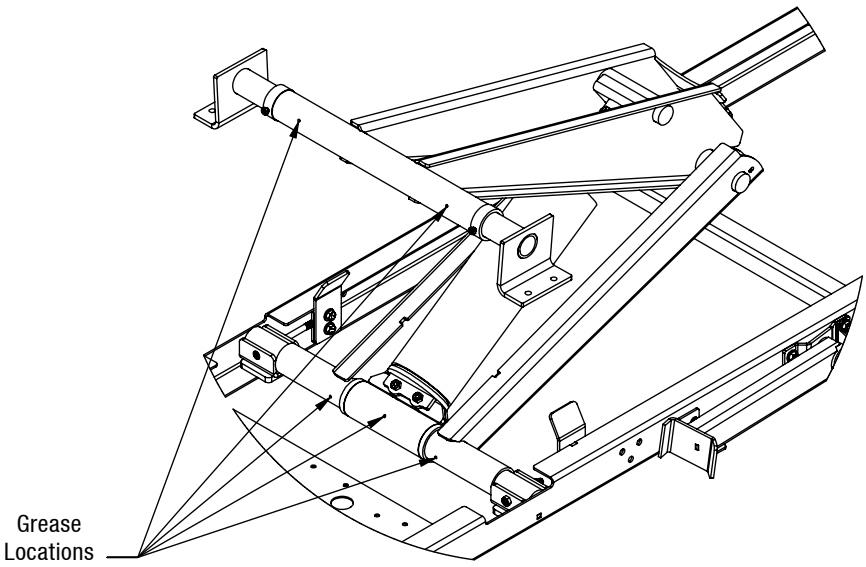

Figure 8: Grease Fitting Locations

9. Install and grease the fittings as shown in Figure 8.

Hydraulic Systems

Crysteel offers PTO driven, gear pump hydraulic systems for use with the LBS-516 model hoist. Mounting instructions can be found on the following pages:

- PTO-driven Gear Pump with Remote Reservoir Valve - page 18
- Electric Pumps: General - page 22
- Electric Pumps: Single-Acting - page 24
- Electric Pumps: Double-Acting - page 25

Installing the Gear Pump

The gear pump has an SAE A mounting configuration, a 9-tooth splined-shaft and a two-bolt mounting flange, and is assembled for counter-clockwise rotation.

NOTE: This pump will mount directly to Chelsea's output type 'XE' or Muncie's output type 'R'.

Crysteel Manufacturing Inc. recommends a PTO ratio of 100-120%. This ensures a minimum pump operating speed of 600 RPM.

CHECK THE PTO ROTATION. If it is opposite the engine, then the pump can be used as is. If the PTO rotation is the same as the engine, then the pump will need to be reversed (see the instructions included with the pump).

Bolt the gear pump to the PTO output flange using 3/8" x 1" capscrews and lock washers.

NOTE: Gear pumps are also available to fit the Muncie or Chelsea PTOs with 11-tooth splined outputs.

Mounting the Reservoir/Valve Assembly

The reservoir/valve assembly is intended to be mounted just behind the cab, between the longbeams of the body with the control valve to the back side of the reservoir. Bolt the reservoir/valve assembly to this mounting bracket using 3/8 x 1" capscrews, flat washers and hex lock nuts.

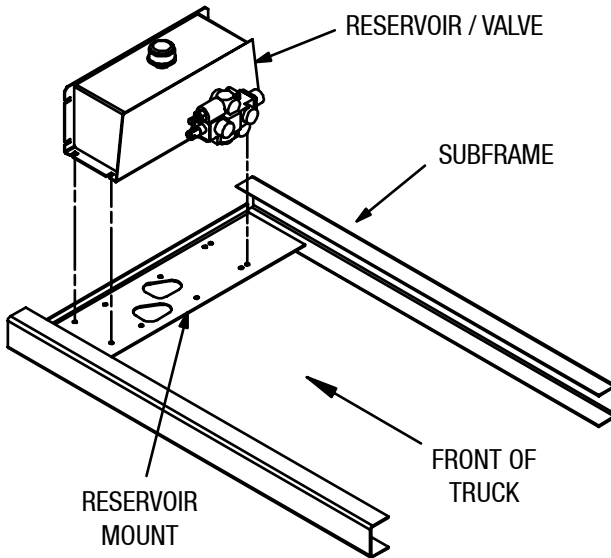

Figure 9: Reservoir/Valve Mounting for LBS-516

Installing the Hoist Control

1. Mount the hoist control decal on the pedestal aligning the holes for the PTO cable and indicator light.
2. Temporarily assemble the valve control head to the pedestal using 5/16" x 2-1/4" machine screws and hex nuts.
3. Place the assembly on the floor of the cab.

NOTE:

- Ensure there is enough room to operate the valve control, gear shift lever, and to adjust the seat.
 - Check below the floor for obstructions and cable routing.
 - Relocate the valve control if necessary.
4. Mark the floor using the pedestal as a template.
 5. Drill 5/16" holes for the mounting screws and a 3/4" hole for the control cable.
 6. Assemble the control cable to the valve control head.
 7. Assemble the valve control head and cover to the pedestal using 5/16" x 2-1/4" machine screws and hex lock nuts.
 8. Insert the control cable through the hole in the floor and mount the pedestal to the floor using 5/16" x 1/2" machine screws and hex lock nuts.

NOTE:

- Ensure the valve control lever is in the center detent position.
 - Route the control cable away from hot exhaust pipes and rotating driveshafts.
 - Verify the control cable does not have any sharp bends or kinks in it as these will make the control more difficult to operate
9. Install the 3/4" hex jam nut onto the valve end of the control cable and tighten it past the threads.
 10. Insert the end of the cable through the bonnet clamp.
 11. Install the bonnet onto the control cable and tighten it past the threads.
 12. Install the 1/4" hex jam nut and terminal eye onto the cable core rod.
 13. Secure the terminal eye to the cable core rod using the hex jam nut.
 14. Place the terminal eye into the valve spool slot.
 15. Insert the short pin through the valve spool and terminal eye and secure it with the e-ring.

16. Thread the bonnet onto the end of the cable so it firmly touches the end of the valve.
- NOTE:** NEVER over- or under-tighten the bonnet as either will move the valve spool out of its neutral position.
17. Remove the two capscrews from opposite corners of the seal retainer plate.
18. Slide the bonnet clamp onto the bonnet and secure it to the valve using the 1/4" x 1-1/4" capscrews, lock washers, and flat washers.
19. Lock the bonnet to the cable using the 3/4 hex jam nut.

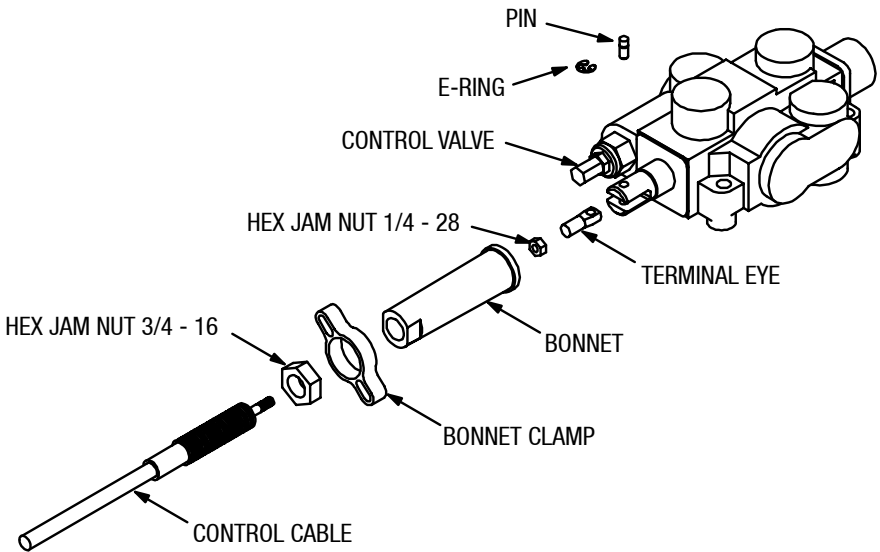

Figure 10: Hoist Control Assembly

Installing Hoses

Study Figure 11 very carefully before connecting the hoses.

1. Install a 3/4" 90° street elbow and a 3/4" hose barb in the suction port on the bottom of the reservoir.
2. Install a 1 1/16 ORB x 3/4" hose barb in the suction port of the pump and install a 3/4" ID suction hose.
3. Secure the suction hose in place using hose clamps.
4. Install a 7/8 ORB x 3/8 NPT 90° adapter in the 'IN' port of the control valve and a 7/8 ORB x 3/8 NPT adapter in the pressure port of the pump.
5. Connect a 72" long 3/8" hose between the pump and the valve.
6. Install straight adapters in both cylinder ports.
7. Install 90° swivel adapters in the work ports of the control valve. Connect the shorter 3/8" hose from the 'B' port on the control valve to the base end port on the cylinder; connect the longer 3/8" hose from the 'A' port to the rod end port. This will raise the hoist when the control lever is pulled back and lower it when pushed forward.
NOTE: The 'A' port is the 'power-down' port and has a pressure of only 500-1000 PSI; the 'B' port has full system pressure.

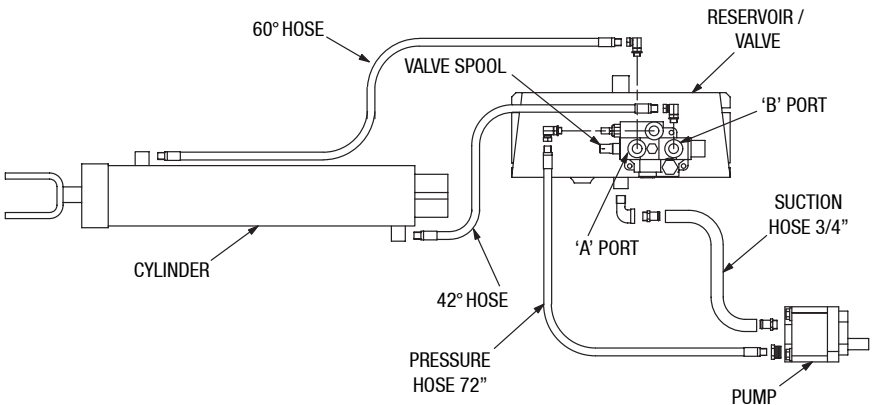

Figure 11: Hose Connections

Electric Pump Mounting



CAUTION Avoid brake lines, wiring, and other vehicle components inside the truck frame when drilling.

The electric power unit should be mounted close behind the cab between the longbeams of the body.

1. After determining the location, bolt the pump to the bracket provided using the 3/8" x 1" capscrews, flat washers, and hex lock nuts tightened to 24 to 26 lb-ft.
2. Measure the voltage between the large terminal of the start solenoid (where the battery cable is connected) and the power unit base. For rated performance, the voltage at the power unit must be a minimum of 12VDC.

NOTE: Grounding the power unit is just as important as the installation of the positive battery cable. Grounding of the power unit can be completed either through the vehicle chassis or by a second battery cable. It is easier to get a good ground by using a second battery cable.

3. Connect the large terminal on the motor start solenoid to the positive terminal on the battery with a #0 gauge battery cable.
 - If grounding through the vehicle chassis, be sure to replace the light ground strap between the battery and the vehicle chassis with a #0 gauge cable.
 - If grounding with a second battery cable, connect the negative terminal on the battery to the grounding hole on the power unit base using an #0 size battery cable.

4. Check the voltage between the large terminal on the start solenoid and the power unit base.

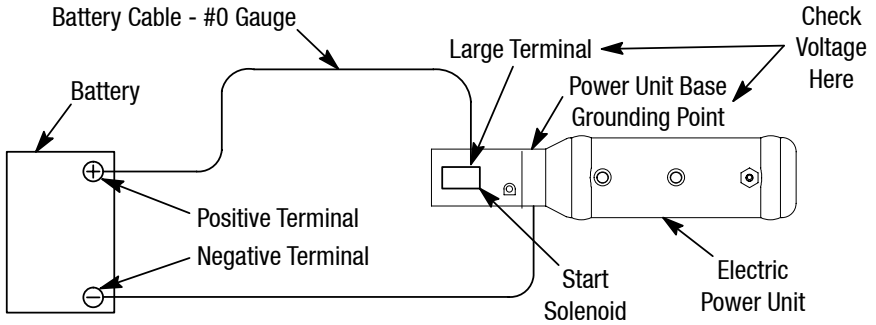

Figure 12: Battery Connections

5. Locate the push-button control in the cab and route the cable out of the cab through a hole in the back of the cab. Connect the push-button control to the electric power unit using the 3-pin connector set.
6. Secure the reservoir with the rubber pad beneath it using the long tie-strap included with the electric power unit.

Installing Single-Acting Electric Pumps

1. Install a 9/16 ORBM x 3/4-16 JIC male straight adapter in the power port on the pump attached to a 3/4 JICF x 3/4 JICM 90° adapter.
2. Install a 1/4 NPT x 3/4-16 JIC male elbow in the port on the top of the reservoir.
3. Connect the shorter hose from the power port on the pump to the base end port on the cylinder.
4. Connect the longer hose from the port on the top of the reservoir to the rod end port on the cylinder.

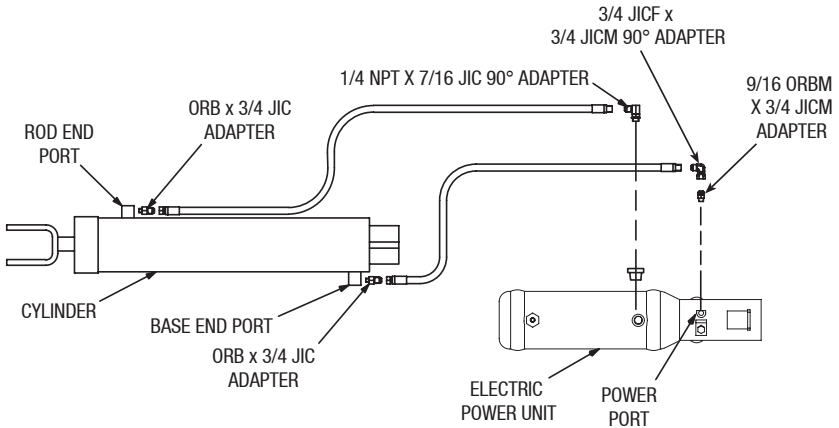

Figure 13: Single-Acting Hoses

Installing Double-Acting Electric Pumps

1. Install 9/16 ORB x 3/4 JIC 90° swivel adapters in both work ports on the electric pump.

NOTE: If needed, for good hose routing, install 3/4 JIC x 3/4 JIC 90° swivel adapters to both of these adapters.

2. Connect the shorter 3/8" ID hose with 3/4 JIC fittings from the 'C1' port on the pump to the base end port on the cylinder.
3. Connect the longer 3/8" ID hose with 3/4 JIC fittings from the 'C2' port to the rod end port.

NOTE: The 'C2' port is the power down port and has only 500 PSI maximum pressure.

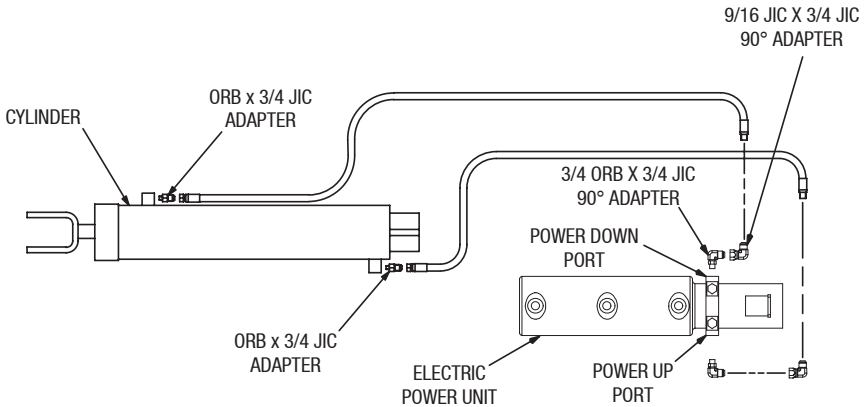

Figure 14: Double-Acting Hoses

Adding Hydraulic Fluid

1. Add a quality hydraulic fluid of 150 SSU @ 100°F which contains corrosion and oxidation inhibitors and a foam depressant. This is approximately the equivalent of SAE 10W or lighter weight oil. Initially fill the reservoir with the quantities given below.

**KEEP THE OIL CLEAN AND USE CLEAN CONTAINERS, FUNNELS, AND OTHER EQUIPMENT!
NEVER OVERFILL THE RESERVOIR!**

Type	Fluid Required
Standard Gear Pump w/Valve Tank	10 quarts
Single-Acting Electric Pumps	7 quarts
Double-Acting Electric Pumps ⁰	7 quarts

NOTE: If the pump does not pump oil, pressurize the reservoir and engage the pump with the engine at slow idle. Once the pump is working, release the pressure and install the breather cap.

2. Before mounting the body, the hoist must be completely closed to make certain that the hoist gives full lift height and performance and verify the lift angles are straight up and down.
 - For hydraulic systems with the direct mount gear pump:
Start the truck engine, engage the PTO and power down the hoist to “bottom-out” the hydraulic cylinder and the hoist frame. Place the hoist valve control in the “hold” position. Both the hoist frame and the hydraulic cylinder are now completely closed.
 - For hydraulic systems with the single-acting electric pump:
Press and hold the `DOWN` push-button on the control while pushing the hoist frame closed. Release the `DOWN` push-button. Both the hoist frame and the hydraulic cylinder are now completely closed.
 - For hydraulic systems with the double-acting electric pump:
Press and hold the `DOWN` push-button on the control to “bottom-out” the hydraulic cylinder and the hoist frame. Release the `DOWN` push-button. Both the hoist frame and the hydraulic cylinder are now completely closed.

Installing the Tipper Body

DANGER

NEVER position yourself or allow others under a raised body as this can result in serious injury or death should the body inadvertently descend. ALWAYS prop up the **unloaded** body using the body props.

1. Place the front of the tipper body on the truck aligned with the front of the subframe.
2. Align the body longbeams to the subframe rails.
3. Securely weld the rear hinge brackets and the hoist lift brackets to the longbeams.
4. Raise the body and block it in a raised position.
5. Securely weld the hoist lift brackets to the fill plates on the inside of the longbeams.
6. If the body and subframe have been assembled at the factory, finish welding the hoist lift brackets to the fill plates on the inside of the longbeams.

Section 4: Decal Locations

DANGER

Missing or damaged decals can lead to accidents which may cause serious injury or death. Replace any missing or damaged decals immediately by contacting a Crysteel dealer or Crysteel Manufacturing Inc.

Two Body Prop Operation decals are supplied with each LBS-series hoist. These decals must be positioned as shown in Figure 16 on both the left- and right-hand sides of the truck. The chosen decal location should be free of any viewing obstructions.

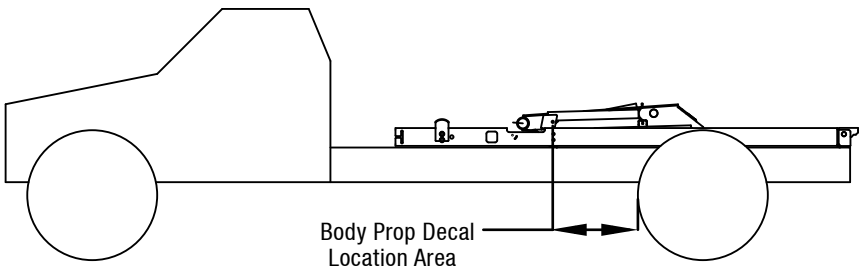

Figure 16: Body Prop Decal Location

Two Danger decals are supplied with each LBS-series hoist. These decals must be positioned as shown in Figure 17 on both the left- and right-hand sides of the truck. The chosen decal locations should be free of any viewing obstructions.

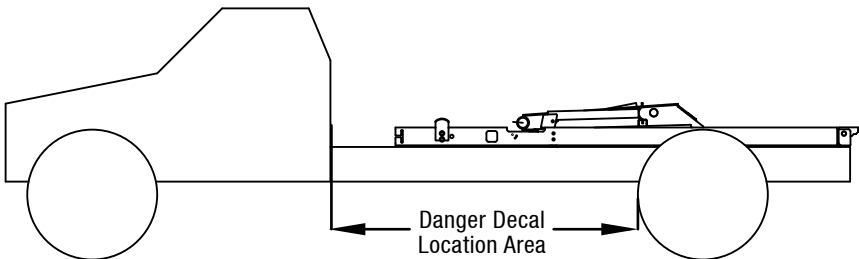

Figure 17: Danger Decal Location

Section 5: Operation

DANGER

NEVER position yourself or allow others under a raised body as this can result in serious injury or death should the body inadvertently descend. ALWAYS prop up the **unloaded** body using the body props.

Raising the Prop Body

1. Raise the unloaded body to the sufficient height and shut off all power.
2. While positioning yourself as far as possible from underneath the truck, grasp the prop from the stowed position.
3. Rotate the prop upwards to just beyond the vertical position.

Lowering the Prop Body

1. While positioning yourself as far as possible from underneath the truck, grasp the prop from the deployed position.
2. Rotate the prop downward to the horizontal position.
3. Lower the unloaded body to the sufficient height and shut off all power.

Section 6: Maintenance

Every 100 cycles or every two months, whichever comes first:

- Grease all hoist and rear hinge grease fittings. Some grease fittings are in hard to find locations. Refer to page 16 for all grease fitting locations.
- Check hardware regularly and re-tighten as needed. Refer to page 10 for torque guidelines.
- Check hydraulic components regularly for any leaks or signs of wear. Replace damaged or leaking components as needed.
- Change hydraulic oil annually with normal use and working conditions. The breather cap should be cleaned every time the hydraulic oil is changed. With heavy use or very dusty working conditions the hydraulic oil should be changed more often.

Refer to the pump or hydraulic components installation and operation manual for more service information.

Section 7: Exploded Views

LBS-516 Model

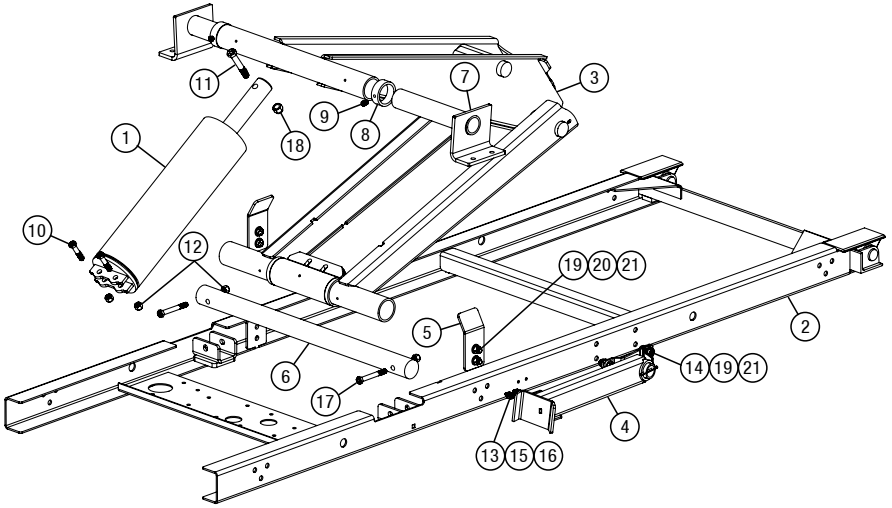

LBS-516 Model Parts List

Item	Part #	Description	Qty
1	1954444	ASSY CYLINDER 5.5 X 16 W/ 2.00 S TB-14 P	1
2	2447963	ASSY SUBFRAME 9' LBS-516 PNT	1
3	2441881	ASSY, HOIST FRAME, LBS-516 PAINT	1
4	2441878	KIT, BODY PROP BOLT-ON, LBS LEFT	1
5	2447017	BODY GUIDE LBS PNT	2
6	2441874	SHAFT, LBS SADDLE PIVOT	1
7	2440766	ASSY BRACKET, LBS LIFT	2
8	2440767	COLLAR, 2.25 LOCK LBS	2
9	1644364	SCREW CAP 3/8 UNC X 16 X 1/2	2
10	1620051	HEXBOLT, 1/2-13 X 2.50, GR 8 TAR	2
11	1620062	HEXBOLT, 5/8-11 X 4.00, GR 8 FBG TAL	1
12	1620103	NUT, NYLOC, 1/2-13 FAD TAU	4
13	1620012	HEXBOLT, 1/4-20 X 1.00, GR 5 TA4	2
14	1620047	HEXBOLT, 1/2-13 X 1.50, GR 8 TAQ	4
15	1620086	NUT, HEX, 1/4-20 TA6	2
16	1642740	WASHER FLAT 1/4	4
17	1642958	SCREW CAP 1/2 x 4 NC G8	2
18	1643070	NUT HEX 5/8-11 LOCK	1
19	1643531	NUT HEX LOCK 1/2 - 13	8
20	1644747	SCREW CAP 1/2 X 1-1/2 -13 G5	4
21	1644936	WASHER FLAT 1/2 ZINC PLATED SAE	16



If questions exist, call your Crysteel representative at 800-533-0494 for further information.

Crysteel Manufacturing Inc.

52182 Ember Road
Lake Crystal, MN 56055



Subsidiary of Federal Signal Corporation

www.crysteel.com

Application Policy

Capacity ratings, features, and specifications vary depending upon the model and type of service. Application approvals must be obtained from Crysteel Manufacturing Inc.; contact your representative for application approval. We reserve the right to change or modify our product specifications, configurations, or dimensions at any time without notice.