

CRYSTEEL'S

LOBOY-ST4000

HOIST

MOUNTING AND OPERATING INSTRUCTIONS



P.O. Box 178
52182 Ember Road
Lake Crystal, MN 56055

www.crysteel.com
crysteel@crysteel.com
(507) 726-2728 (800) 533-0494

1902 Route 57 South
Fulton, NY 13069

LO-BOY ST-4000 TRUCK HOIST

DATE PURCHASED _____

SERIAL NUMBER ON HOIST _____

SERIAL NUMBER ON CYLINDER _____

SERIAL NUMBER ON PUMP _____

FOREWORD

This manual contains information necessary for the proper installation and operation of this truck hoist. Study it carefully before attempting to mount the hoist. With proper installation and maintainance the Lo-Boy Model ST-4000 truck hoist will give many years of trouble free service.

When ordering parts be sure to give serial number of both pump and cylinders. The serial number of the pump is found on the plate on the front of the pump. The serial number of the cylinder is stamped on the barrel of the cylinder near the base. For future reference, copy these numbers NOW in the space provided above. Order parts by number and description as given in the parts listing in this manual.

If you prefer, parts for the pump may be ordered directly from the manufacturer of the pump as per the information supplied with the pump, which can be considered to be part of this manual. If you do this, specify that the built-in relief valve be set to operate at 4000 P.S.I. and that your pump is part of the Lo-Boy Model ST-4000 truck hoist.

THE LO-BOY MODEL ST-4000 TRUCK HOIST IS DESIGNED AND INTENDED FOR USE ON TANDEM AXLE TRUCKS WITH CAB-TO-TRUNION DIMENSIONS OF 120 INCHES THROUGH 181 INCHES AND BODY LENGTHS OF 14 FEET THROUGH 24 FEET.

KEEP THIS MANUAL IN A SAFE PLACE FOR FUTURE REFERENCE

SAFETY FIRST

NEVER EXCEED THE G.V.W. (GROSS VEHICLE WEIGHT) RATING NOR THE G.A.W. (GROSS AXLE WEIGHT) RATING SPECIFIED FOR YOUR TRUCK.

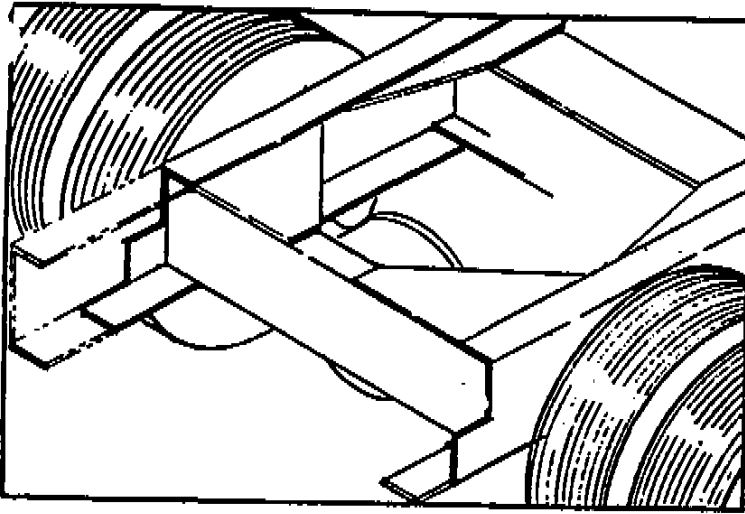
MOUNTING INSTRUCTIONSLOCATE REAR HINGE

The rear hinge is pre-assembled for ease of installation. Remove the extension tube brackets No. 4 from the center assembly No. 5. Mark the truck frame as shown by using the center assembly as a guide. Mark the top flange 1/4 inch behind the rear truck frame crossmember. (This will usually be from 42 to 45 inches behind the C.T.) The rear hinge should never be more than 50 inches behind the C.T. Mark straight down 5 in., back 5 in., down to the bottom flange, then leave enough of the bottom flange intact to bend up later to box in the frame as shown.

TORCH CUT THE FRAME AS MARKED

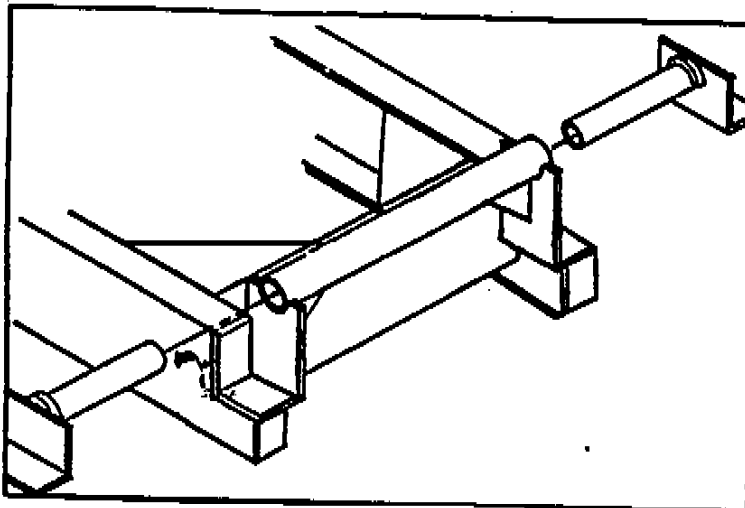
INSTALL REAR HINGE

Set the rear hinge in place. The top of the angle brackets of the center assembly No. 5 should be flush with the top of the truck frame. The vertical half inch plates of the hinge assembly should be against the rear surface of the truck frame crossmember. Check to make sure it is centered and square with the truck frame. Weld the rear hinge assembly very securely to the truck frame at all contact points, especially to the rear surface of the truck frame crossmember. If necessary, grind the weld smooth at the top of the truck frame. Bend the lower flange of the truck frame up to the hinge angle to box in the lower part of the truck frame and weld securely. Replace the extension tube brackets No. 4 in the center assembly No. 5 as far in as possible against the stops, so there will be NO SIDEPLAY in the rear hinge.

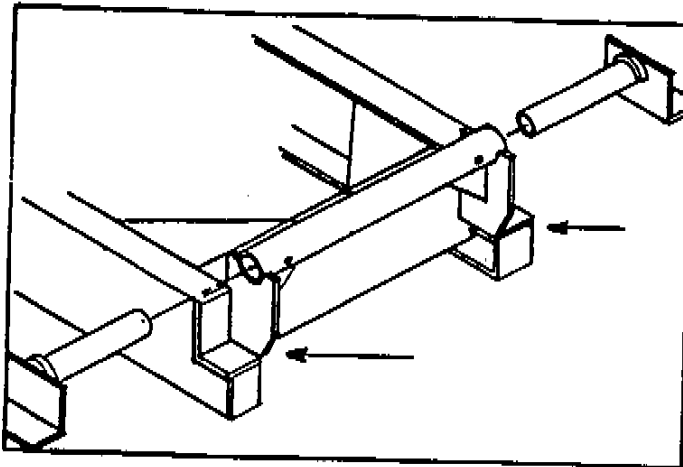

LOCATE HOIST ON TRUCK FRAME

The rear end of the main hoist frame No. 3 is designed to rest on the truck frame crossmember approximately in line with the front edge of the front tires of the tandem. This will result in a normal installation with a dump angle of about 45 degrees. For steeper dump angles it can be mounted farther back. NOTE: In some cases the hoist may fit the truck frame better if it is mounted "backwards" as shown below. For dump angles steeper than 50 degrees, it will be necessary to trim the rear corners off the rear hinge as shown here, so the longbeams will not strike the hinge angle when hoisted.

Measure the distance "D" as shown below from the center of the rear hinge tube to the center of the upper crosstube shown in the following chart:

DETERMINE DUMP ANGLE

94 inches - 60 degrees	109 inches - 51 degrees	122 inches - 45 degrees
100 inches - 56 degrees	117 inches - 49 degrees	136 inches - 42 degrees
105 inches - 53 degrees	113 inches - 47 degrees	130 inches - 40 degrees

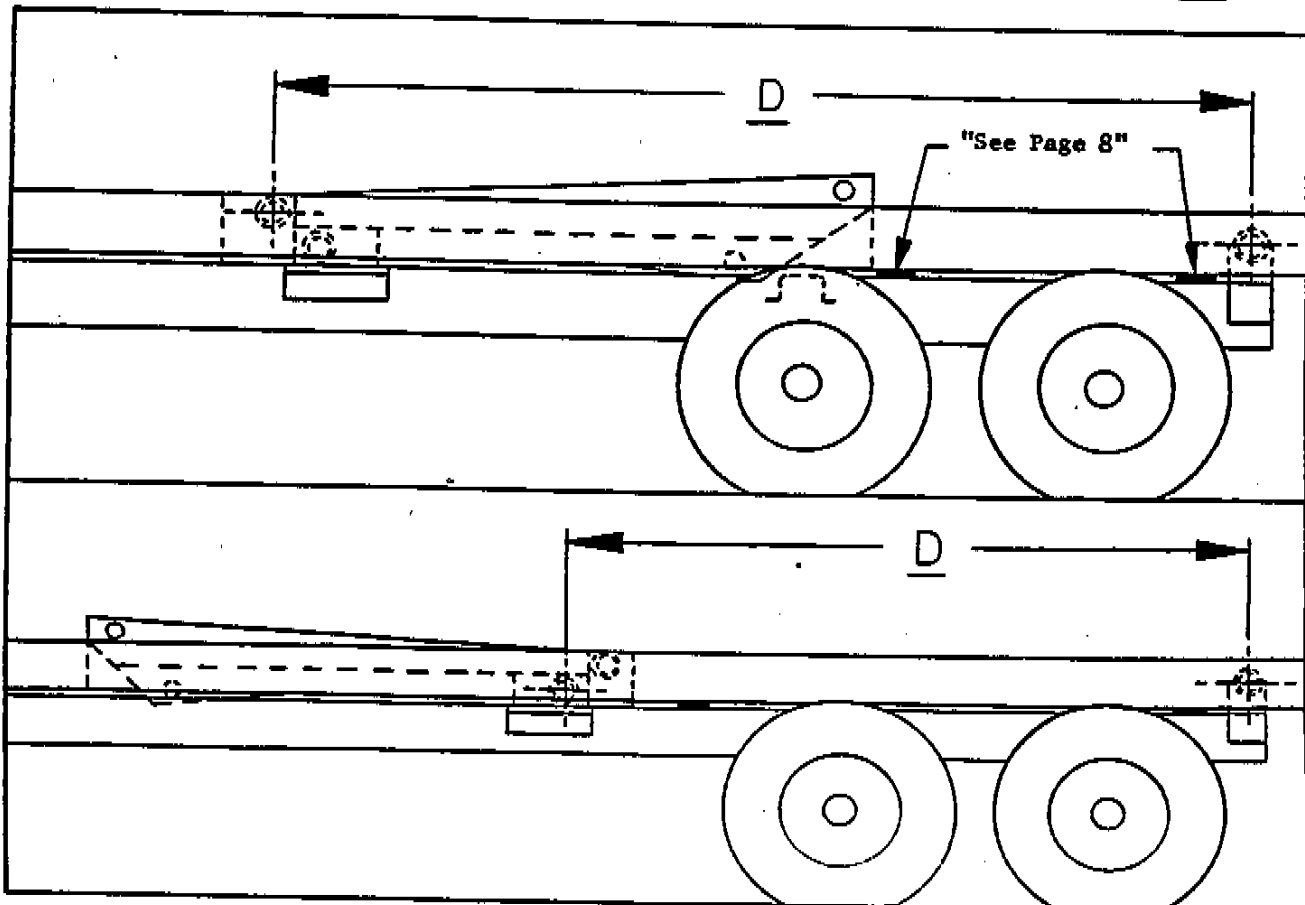

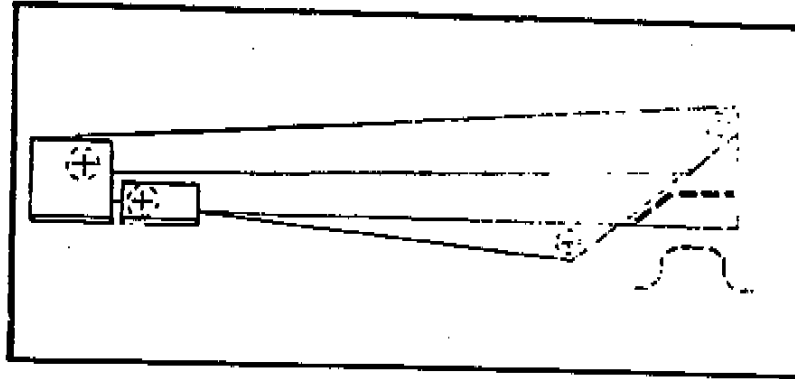

SPECIAL INSTRUCTIONS FOR SOME INSTALLATIONS

1. If it is desired to lower the rear end of the hoist that rests on the truck frame crossmember, in order to avoid notching underbody crossmembers; this can be done by notching the rear of the hoist **BEHIND THE SLANTED HEADPLATE** as shown by the heavy dotted line. Notch these plates as required, trim the cut off pieces and weld them back on at a higher level. The hoist can be lowered as much as 4 inches this way **IF THERE IS SUFFICIENT DRIVESHAFT CLEARANCE**.
2. If it is desired to locate the hoist where there is not a truck frame crossmember to support the rear end of the hoist, add a new crossmember for this purpose. A piece of six inch channel will suffice for this.

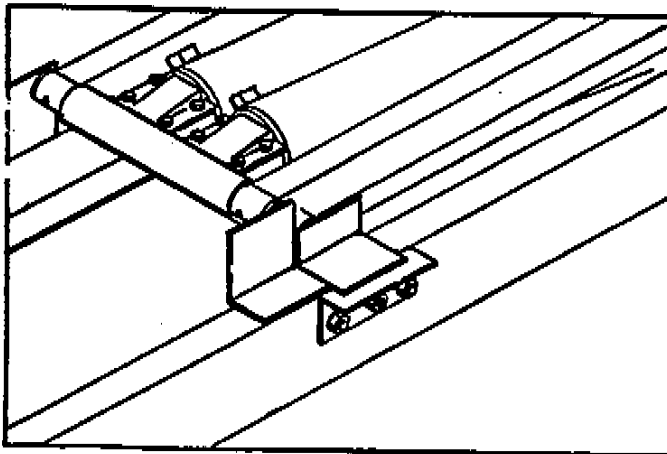

MOUNT HOIST TO TRUCK FRAME

The angle brackets of the hoist must rest flat on truck frame. If rivets are encountered in truck frame and the hoist cannot be moved to clear them, countersink rivet heads into the brackets. Center the mounting angles No. 19 under the hoist brackets, clamp them in place and drill 21/32 holes in truck frame. Bolt the mounting angles No. 19 to truck frame, using 5/8 x 1 3/4 machine bolts and lockwashers. **CAUTION:** When drilling in truck frame, be careful of brakelines, wiring, etc. inside the truck frame.

WELD BRACKETS TO MOUNTING ANGLES

Re-check to make sure hoist is centered and square with truck frame. Weld the angle brackets of the hoist very securely to mounting angles.

LO-BOY ST-4000 TRUCK HOIST

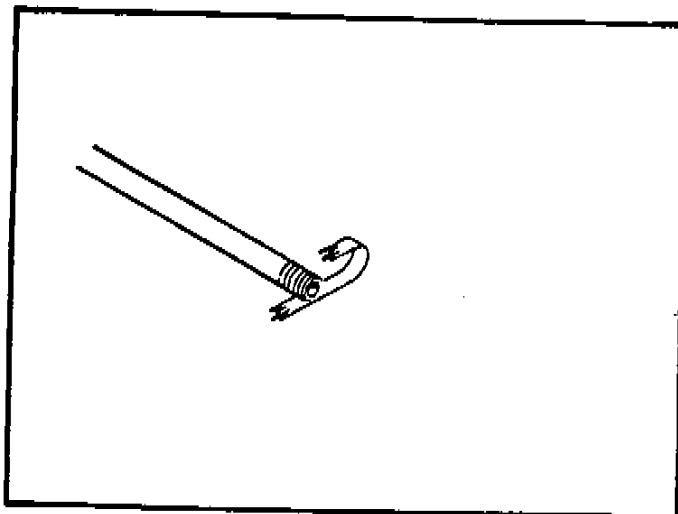

PLUMBING AND USE OF TEFLON TAPE

Use teflon tape on all hydraulic connections. Properly done, this will assure absolutely leakproof connections. All connections are 3/8 in. pipe. One wrap of teflon tape is enough — use it sparingly. Rather than cutting, break off about 2 inches of teflon tape. This will provide a feathered edge, for easier assembly. Stretch it tight so that it sinks deeply into the threads. Be sure to wrap the tape in the same direction the fitting screws on so it will stay in place as the fitting is threaded on. It is not necessary to tighten the connections excessively.

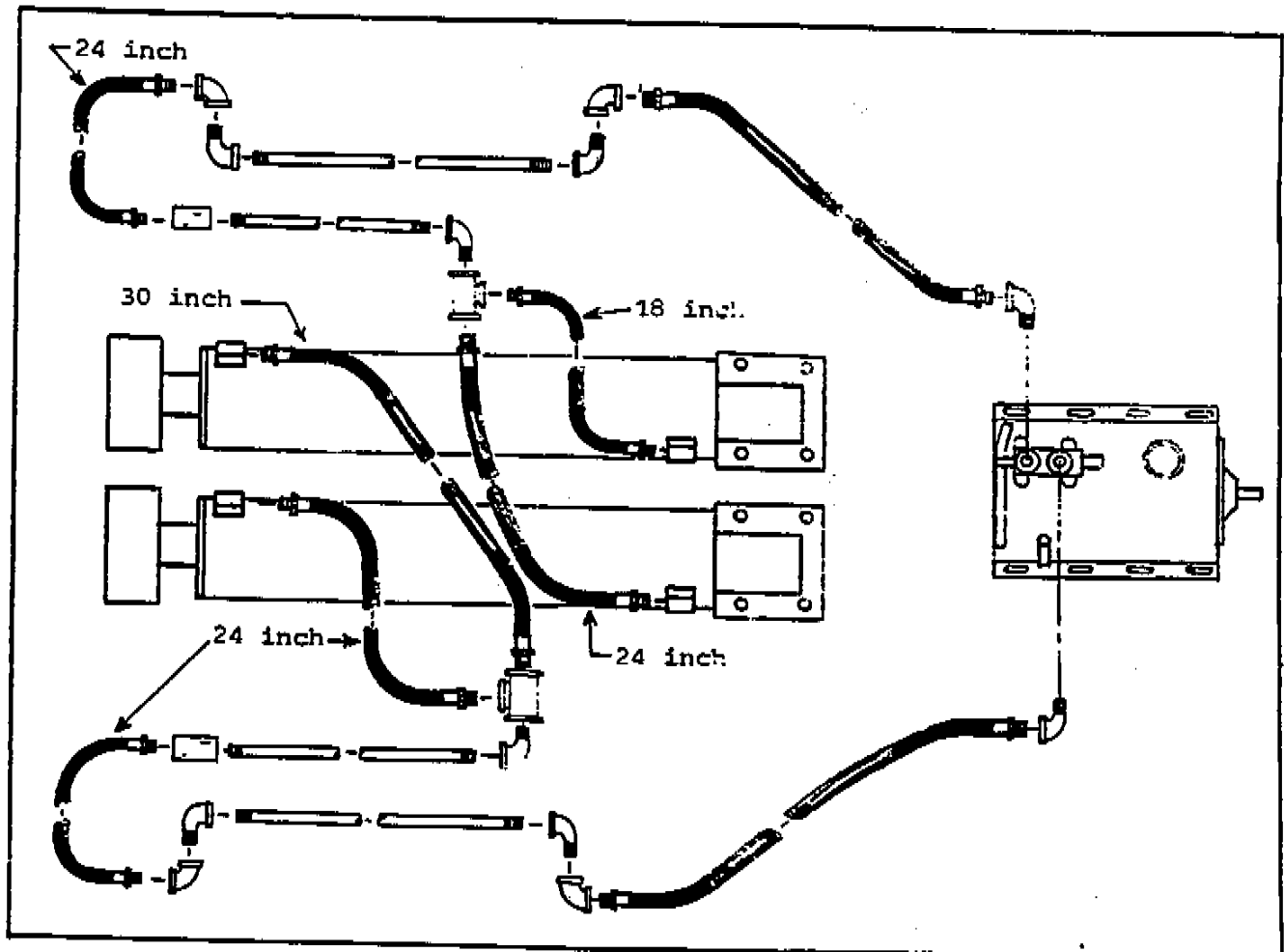

LO-BOY ST-4000 TRUCK HOIST

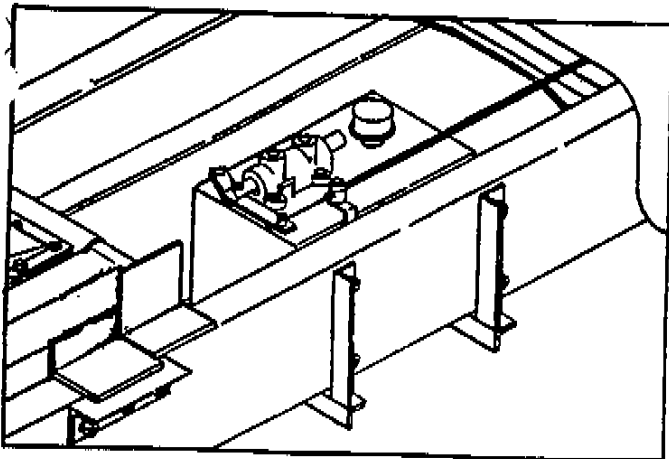
ATTACH MOUNTING ANGLES TO PUMP

Determine on which side of the truck frame to mount the pump. (Same side as the PTO). Bolt the pump mounting angles No. 33 to the pump No. 20, using 3/8 x 1 machine bolts, flat washers and lock-washers.

MOUNT HYDRAULIC PUMP

Temporarily clamp the pump mounting angles to the truck frame, with the pump inside the truck frame a few inches behind the cab. Check to be sure of sufficient clearance and that PTO driveshaft is long enough. In some cases it will be necessary to re-work the exhaust system for clearance. **UNDER NO CIRCUMSTANCES SHOULD THE ENGINE EXHAUST BE PERMITTED TO BLOW DIRECTLY ONTO THE PUMP!** The PTO driveline must never exceed 15 degrees angularity. After locating the pump, drill 17/32 diameter holes through the truck frame and bolt tight, using 1/2 x 1 1/2 inch machine bolts and lock-washers.

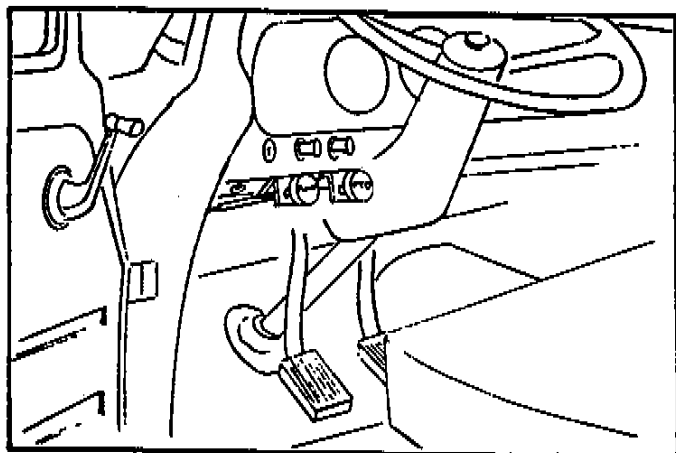
INSTALL CABLE CONTROL NO. 23

Remove control wire from cable housing and oil inside of cable housing before installing. Attach control mounting angle No. 24 at a convenient location under the dash, using the 1/4 x 3/4 machine bolts and lockwashers. Install cable through firewall and connect to valve control lever. Check and adjust for proper operation. Be sure there are no sharp bends in cable.

LO-BOY ST-4000 TRUCK HOIST**PLUMBING HYDRAULIC CYLINDERS**

Study the plumbing diagram shown on page -6- very carefully and follow it EXACTLY! Remove port plugs from cylinders. Starting at the pipe tee No. 7 on the left (driver's) side on the inside of the upper hoist frame, run a 24 inch hose No. 12 through the front hole in the center tension bar of the hoist frame to the base end (front end) of the right hand cylinder; and an 18 inch hose No. 46 to the base end of the left cylinder. Starting again at the pipe tee No. 7 on the right side, run a 30 inch hose No. 47 through the rear hole in the center tension bar of the hoist, to the head (shaft) end of the left cylinder; and a 24 inch hose No. 12 to the head end of the right cylinder. The swivel end of all hoses should be connected to the cylinder ports. NOTE: Final tightening of hoses at the HEAD end of cylinders will be easier if left until later when the hoist is raised.

COMPLETE HYDRAULIC PLUMBING

On each side of the hoist, 24 inch hoses No. 12 are tucked inside the upper frame. One end is already connected inside the frame. Connect the other end to the elbow near the cylinder crosshead pin. (See lubrication photo on page 11). Install a 90 degree street elbow in each port of the pump valve. Connect the 36 inch hose No. 16 to the hoist hydraulic line on the same side of the truck as the pump. Connect the 42 inch hose No. 40 to the other side. Connect the hose on the left (driver's) side to the valve port nearest the rear of the truck, as shown on the plumbing diagram. Connect the other line to the front valve port. This is very important because the rear port has full hydraulic pressure, the front port only half as much pressure.

INSTALL PTO DRIVELINE

Install the long U-slip joint No. 48 on the pump driveshaft, and the short U-joint No. 30 on the PTO driveshaft so that the inner edge of the hub of each is flush with the end of the shaft. DO NOT TIGHTEN SETSCREWS. Measure the exact length of the square driveshaft No. 28 needed between the two U-joints so that the shaft will be flush with the inner edge of both hubs. Cut the square driveshaft to proper length with a hacksaw and grind off any burr. Insert shaft into the slipjoint hub. Slide both joints farther onto the shafts and insert the square driveshaft into the short U-joint hub. Re-locate the joints in their proper position. Tighten the setscrews No. 29 very tight and secure with a safety wire.

INSTALL TRUCK BODY

Assuming that steel longbeams are attached to the body, place the body in position on the truck. ALLOW AT LEAST TWO INCHES OF CLEARANCE BEHIND CAB. Depending upon the size of the longbeams and the mounting height of the hoist (See page 5), it may be necessary to do some notching of the under-body crossmembers. The design of the hoist is such that notching of crossmembers is minimized, and in most cases eliminated. Use the rivet strip mounting pads No. 8 between the longbeams and the truck frame. Use three on each side, spaced as shown on page 4. Weld them to the underside of the longbeams. Align body longbeams carefully with the truck frame.

LO-BOY ST-4000 TRUCK HOIST**ATTACH LONGBEAMS TO REAR HINGE EXTENSION TUBE BRACKETS**

Make sure longbeam extension tube brackets No. 4 are in tight against the stops. Weld the longbeams very securely to the brackets at the bottom. On the inside of the longbeams use the flat spacer No. 6, $3/8 \times 3 \times 7$, to connect the upper flange of the longbeam channel to the top of the bracket as shown. Weld very securely to both the flange of the longbeam and the top of the extension tube bracket.

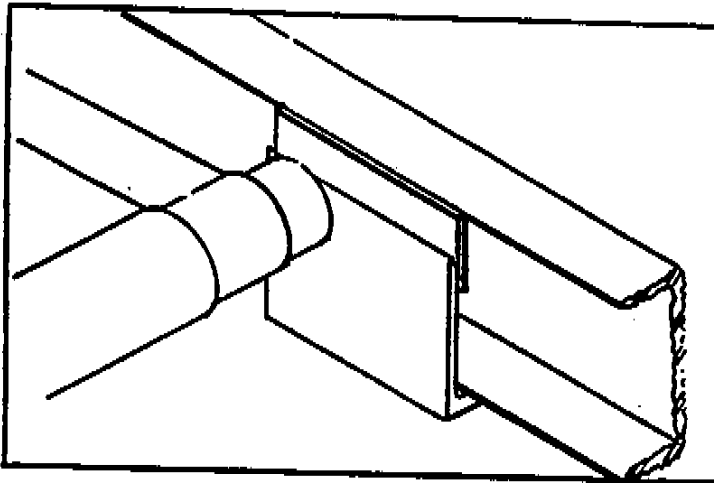
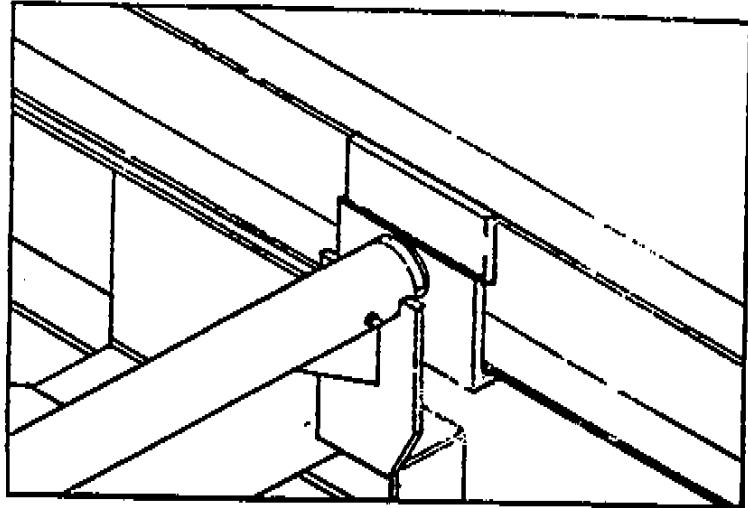
**ATTACH LONGBEAMS TO HOIST LIFT BRACKETS**

Weld the longbeams very securely to the angle lift brackets of the hoist. On the inside of the longbeams use the flat spacer No. 1, $3/8 \times 2 \times 7$ to connect the upper flange of the longbeam channel to the top of the hoist lift bracket as shown. Weld the spacer securely to both the longbeam flange and the hoist bracket. These parts are more easily installed if the hoist is raised part way after welding the longbeams to the brackets at the bottom. **BEFORE WORKING UNDER A RAISED BODY BE SURE IT IS BLOCKED UP VERY CAREFULLY TO PREVENT THE POSSIBILITY OF AN ACCIDENT!!**

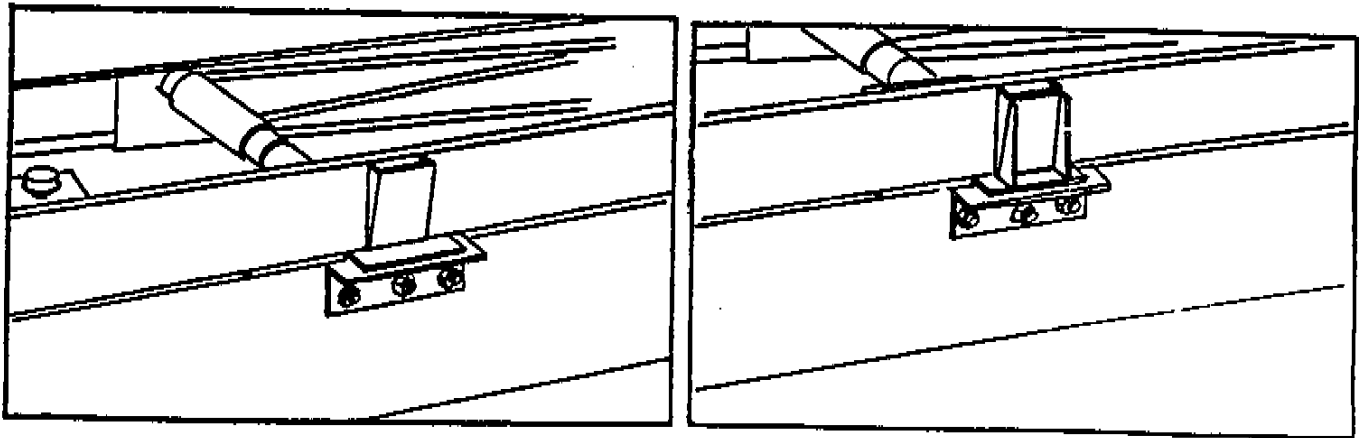

INSTALL BODY GUIDES

The four body guides No. 14 are all identical. Weld one to each longbeam as shown, with the wide end of the body guide at the top and centered over the truck mounting brackets. Now weld the other pair of body guides to the truck mounting brackets, and tight against the first body guides as shown. There should be NO SIDE-PLAY between the body guides when the truck body is in the lowered position.

LUBRICATION INSTRUCTIONS

Install and lubricate grease zerks in the following locations:

- A - Truck mount pivot pin - - - 2 fittings
- B - Longbeam pivot pin - - - 2 fittings
- C - Main center hinge - - - 3 fittings
- D - Cylinder base pivot - - - 2 fittings
- E - Cylinder cross heads - - - 2 fittings
- F - Rear hinge - - - 2 fittings
- G - U-slip joing - - - 1 fitting
- H - Each U-joint - - 2 fittings (These are already installed)

Lubricate all fittings at regular intervals, at least each time the truck chassis is lubricated. There are tremendous forces on the bearing surfaces within the hoist frame, especially the main center hinge and cylinder crosshead. It pays to be generous with the grease gun, to insure proper operation and long life.

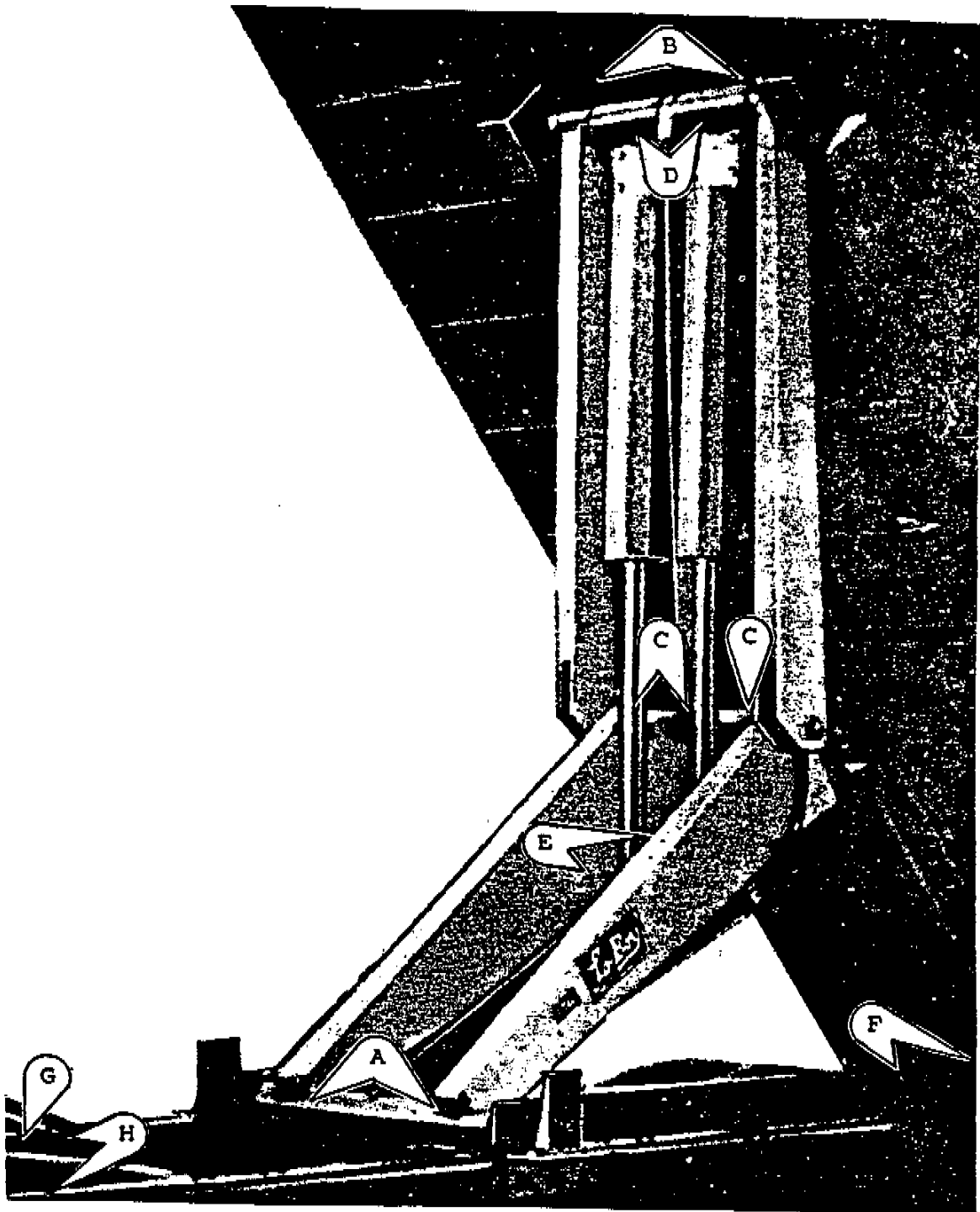

-11-
CRYSTEEL MANUFACTURING, INC.

LO-BOY ST-4000 TRUCK HOIST**OPERATION AND USE**

1. Engage PTO from cab and adjust engine speed to fast idle.
2. If hydraulic plumbing is correct, hoist should raise when pump knob is out, hold when knob is centered, and lower with knob in.
3. Cycle the hoist several times to remove air from the cylinders and hydraulic lines.
4. When hoist cylinders reach the end of the stroke, oil will bypass through the relief valve. Do not permit this for any length of time as it places unnecessary strain on the hydraulic system. Place pump knob in hold position or disengage the PTO.
5. It is advisable to run the PTO to lower the hoist because this will act as a hydraulic lock to hold the hoist closed. It is not necessary to do this, however, because the reservoir has sufficient capacity whether you pump the oil back into the cylinder or not, but you will not benefit from the advantages of double action.
6. To make use of the hydraulic lock feature place knob in center hold position after hoist is pumped all the way down. This places the pressure on the valve where it belongs, not on the pump.
7. **DO NOT LEAVE THE PTO IN GEAR WHILE TRANSPORTING. THIS WILL CAUSE SEVERE DAMAGE TO THE HYDRAULIC PUMP AND/OR DRIVELINE.**
8. The hydraulic system should be drained, flushed, and refilled with proper hydraulic fluid at regular intervals.

CAUTION: NEVER USE HYDRAULIC BRAKE FLUID IN THE HYDRAULIC SYSTEM.

CAPACITY CHART FOR LO-BOY MODEL ST-4000 HOIST			
Level Load Capacity in Tons			
The capacity of any hoist will vary according to the C.T. dimension of the truck, body length, rear overhang, and dump angle.			
C.T. length	Body length	Capacity 45°	Capacity 50°
120"	16'	28 tons	25 tons
120"	17'	30	27
126"	16'	26	23
126"	17'	28	25
138"	17'	24	21
138"	18'	26	23
150"	18'	22	19
150"	19'	24	21
150"	20'	26	23
162"	19'	21	19
162"	20'	22	20
168"	20'	21	19
168"	22'	24	21
174"	20'	20	18
174"	22'	22	20
180"	22'	21	19
180"	24'	24	21

LO-BOY ST-4000 TRUCK HOIST

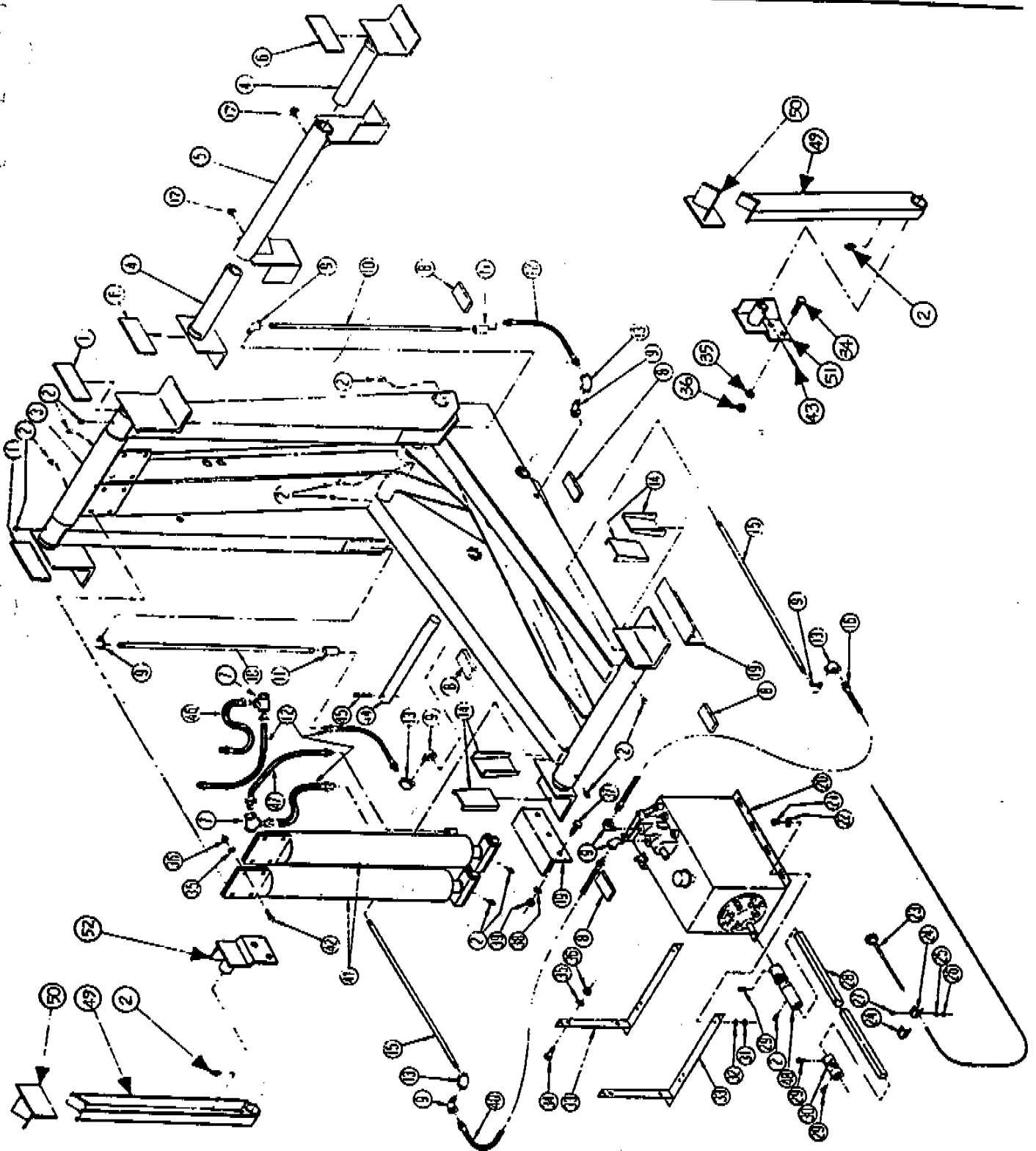

-13-
CRYSTEEL MANUFACTURING, INC.

LO-BOY ST-4000 TRUCK HOIST

PARTS LIST

KEY NO.	PART NO.	DESCRIPTION	QUANTITY
1	200896	Flat spacer 3/8 x 2 x 7	2
2	400103	Grease fitting 1/8-27 straight	11
3	100160	Main hoist frame	1
4	100181	Extension tube, rear hinge	2
5	100178	Rear hinge assembly	1
6	200894	Rear hinge spacer 3/8 x 3 x 7	2
7	400416	3/8 pipe tee	2
8	200890	Rivet clearance strip 1/2 x 2 x 4	6
9	400412	3/8 pipe 90° street elbow	8
10	400566	Hydraulic pipe 3/8 x 21 inch	2
11	400415	3/8 pipe coupling	2
12	400510	3/8 x 24 Hydraulic hose SAE 100R2	4
13	400413	3/8 pipe 90° elbow	4
14	201415	Body guide	4
15	400568	Hydraulic pipe 3/8 x 39 inch	2
16	400512	3/8 x 36 Hydraulic hose SAE 100R2	1
17	400117	1/8-27 90° grease fitting	2
19	201372	Mounting angle	2
20	400324	8 GPM hydraulic pump & reservoir - 1 val.	1
21	400121	3/8 x 1 N.C. cap screw	4
22	400164	3/8 flat washer	4
23	400025	Pump control cable, 12 foot	1
24	201391	Dash control mounting angle	2
25	400163	1/4 Lock washer	4
26	400184	1/4 N.C. hex nut	4
27	400101	1/4 x 3/4 N.C. cap screw	4
28	200885	PTO driveshaft, 7/8 square x 4 feet	1
29	400102	3/8 x 1/2 N.C. setscrew, drilled head	3
30	400578	Standard short U-joint	1
31	400183	3/8 N.C. hex nut	4
32	400162	3/8 lock washer	4
33	100511	Pump mounting angle	2
34	400104	1/2 x 1 3/4 N.C. cap screw	4
35	400161	1/2 lock washer	12
36	400182	1/2 N.C. hex nut	12
37	400100	5/8 x 1-3/4 N.C. cap screw	6
38	400160	5/8 lock washer	6
39	400181	5/8 N.C. hex nut	6
40	400513	3/8 x 42 Hydraulic hose, SAE 100R2	1
41	100228	Hydraulic cylinder assembly	2
42	400105	1/2 x 2 N.C. cap screw	8
43	400220	Roll pin, 1/4x3	2
44	201156	Cylinder crosshead shaft	1
45	400209	1/2 x 2-1/2 roll pin	1
46	400509	3/8 x 18 hydraulic hose, SAE 100R2	1
47	400511	3/8 x 30 hydraulic hose, SAE 100R2	1
48	400583	Long U-slip joint	1
49	101220	Body prop arm assembly	2
50	125259	Longbeam bracket, body prop	2
51	104190	Mounting bracket, body prop, left	1
52	104191	Mounting bracket, body prop, right	1

-14-

CRYSTEEL MANUFACTURING, INC.

LO-BOY ST-4000 TRUCK HOIST

OPTIONAL PARTS LIST

PART NO.	DESCRIPTION	REPLACES KEY NO.	QUANTITY
400026	Pump Control cable 15 foot	23	1
400336	Hyd. pump & res. 8 GPM 2 valves	20	1
400338	Hyd. pump & res. 12 GPM 1 valve	20	1
400339	Hyd. pump & res. 12 GPM 2 valves	20	1
400517	Hyd. hose extension 12 inch long		2
400518	Hyd. hose extension 24 inch long		2
400519	Hyd. hose extension 42 inch long		2

SOME DO'S AND DON'TS FOR SAFETY AND LONG SERVICE LIFE

1. Use the proper hydraulic fluid. **KEEP IT CLEAN.** Remember to change it regularly. (See page 7)
2. Lubricate all grease fittings at regular intervals. (See page 10)
3. **ALWAYS CAREFULLY BLOCK UP THE HOIST BEFORE WORKING UNDER IT.**
4. Do NOT race the engine when unloading.
5. Do NOT overload the hoist beyond its capacity.
6. **DO NOT TAMPER WITH THE HYDRAULIC RELIEF VALVE.** This will void the warranty. It can cause severe damage to hoist and cylinder.
7. **NEVER LEAVE THE PTO IN GEAR WHILE TRANSPORTING. IT WILL RUN THE HYDRAULIC PUMP.**
8. Check all bolts and setscrews regularly. Keep them tight.

CAPACITY FORMULA FOR LO-BOY MODEL ST-4000 HOIST

To determine the capacity of the Lo-Boy Model ST-4000 hoist for applications other than those shown on the capacity charge, use the following formula:

- (1) Measure the distance in inches from center of the rear hinge pin to the center of the body. Call this dimension "A".
- (2) Measure the distance in inches as shown on page 4, from the center of the rear hinge pin to the center of lift point. This is dimension "D".
- (3) Multiply dimension "D" by 29.
- (4) Divide this total by dimension "A". Result will be the level load capacity of the hoist in thousands of pounds, including body weight.

CRYSTEEL MANUFACTURING, INC.

Highway 60 East
LAKE CRYSTAL, MINNESOTA 56055

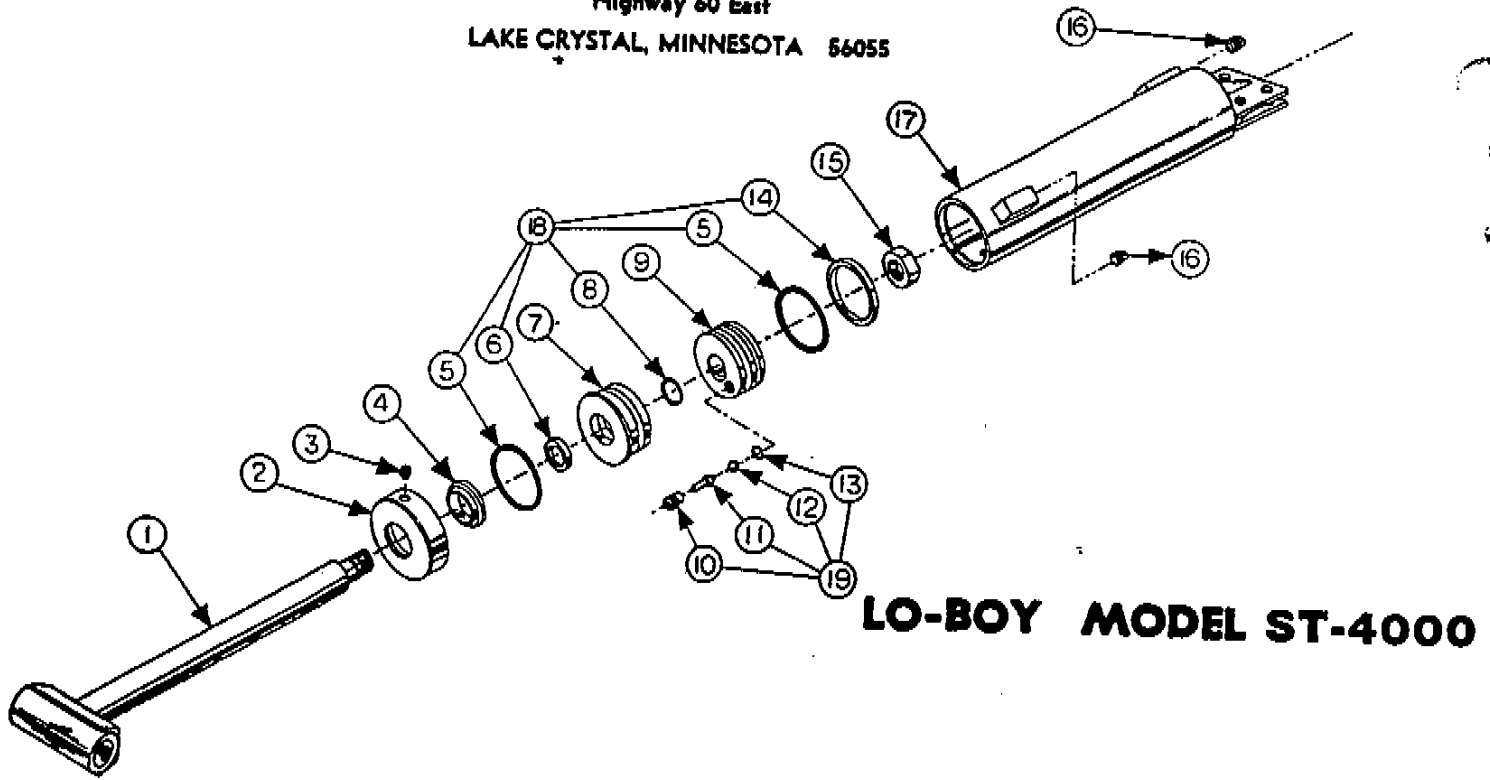

LO-BOY MODEL ST-4000

CYLINDER PARTS LIST MODEL ST-4000 (SERIAL NUMBER 2-4000-001 AND UP)

KEY NO.	PART NO.	DESCRIPTION	QUANTITY
1	104274	Cylinder Shaft Assembly	1
2	104295	Cylinder Cap Assembly	1
3	400149	Set Screw 1/4x3/16, Nylon tip	1
4	400915	Wiper Seal, 2 3/8 inch	1
5	400254	O-Ring 4 1/2 x 5	2
6	400908	Poly Seal 2 3/8 x 2 5/8	1
7	205134	Head	1
8	400255	O-Ring 1 1/2 x 1 5/8	1
9	202461	Piston	1
10	400978	Valve Plug	1
11	400979	Valve Pin	1
12	400013	Ball 3/8	1
13	401017	O-Ring	1
14	400252	Poly Seal 4 1/2 x 5	1
15	401370	Lock Nut 1 1/2	1
16	400422	Pipe Plug 3/8	2
17	104311	Cylinder Tube Assembly	1
18	107960	Seal Kit	
19	105185	Valve Kit	

CRYSTEEL TRUCK BODY PROP

Crysteel's Body Prop is designed and intended for use to support an empty truck body in the raised position to permit service work to be performed safely beneath a raised body. As a general rule, one prop will support a farm type body of 16 feet or less. With longer bodies, two props should be used, one on each side. Crysteel's Body Props come in pairs, driver's side and curb side. Single cylinder hoists come with the prop for the driver's side; twin cylinder hoists come with both props.

INSTALLATION OF TRUCK BODY PROP

Refer to drawings as shown below:

1. Raise body to desired height and brace it securely before beginning installation.
2. Assemble prop arm to prop pivot mount with 1/4 x 3 roll pin. Position prop pivot mount against outside of truck frame just behind rear axle, allowing saddle end of prop arm to rest a top front rear spring shackle as shown. Using prop pivot mount as a guide, mark location of holes on truck frame and drill. Fasten prop pivot mount to truck frame with 1/2 x 1 3/4 bolts, lockwashers and nuts.
3. Raise prop arm to free standing position by allowing prop arm to rest against rear flange of prop pivot mount. Place longbeam bracket in prop arm saddle. Position longbeam bracket against the upper outside of body longbeam in order to allow room for clearance when body is in the lowered position. Weld longbeam bracket securely in place.
4. To operate Truck Body Prop raise body to desired height, shut off all power, raise prop arm to free standing position. Lower body slowly until longbeam bracket contacts prop arm saddle. **DO NOT POWER HOIST DOWN!!!!!!**
5. To place Truck Body Prop in storage position simply reverse the above procedure.

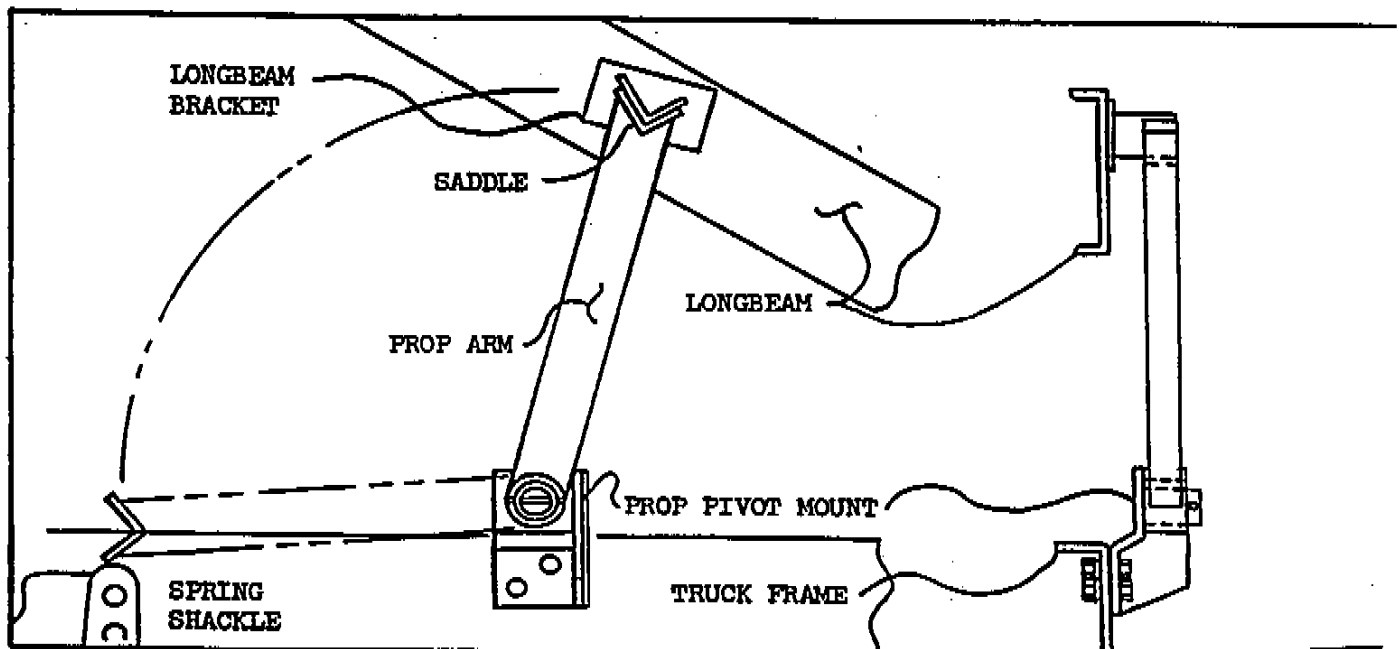

CRYSTEEL MANUFACTURING, INC. -17-

SPECIALLY DESIGNED – WITH QUALITY IN MIND

CUSTOMER SATISFACTION PLEDGE

Crysteel's Customer Satisfaction Pledge is designed to be the most comprehensive warranty in the truck equipment industry. This pledge covers new products for a period of five (5) years, and is not restricted by vehicle mileage or when product is invoiced to our distributors. Our warranty begins when our product is put into service by the final customer.

This warranty covers our products for defective material and/or workmanship at a rate of 100 % for the first (3) years and at a rate of 50 % for years 4 and 5. This warranty covers:

- Crysteel Manufactured product
- OEM Products purchased by Crysteel as part of our product
- The repair of warranted product
- The replacement of warranted product
- Labor to replace warranted product
- Freight for replacement product
- Warranted product return freight (if required)

This warranty is limited to product supplied under the Crysteel Mfg. name and does not cover distributor modifications. Repair or replacement is at Crysteel's option. Primer warranty is limited to adherence to metal surfaces only and does not include the inside or understructure of dump bodies. Crysteel will not assume responsibility for travel, loss of use, downtime expenses or other incidental or consequential damages. This warranty is void if the product has been obviously abused or subjected to other than normal usage. There are no other warranties except as described above, and Crysteel makes no warranty of fitness for a particular purpose.

! CAUTION !

- **BODY MUST BE BRACED BEFORE SERVICING HOIST OR WORKING IN AREA WITH BODY IN RAISED POSITION**
- **LUBRICATE HOIST GREASE FITTINGS OFTEN – AT LEAST EACH TIME TRUCK IS SERVICED**
- **TRUCK MUST BE LEVEL FOR DUMPING**
- **DO NOT OVERLOAD**

CRYSTEEL MFG, INC.

CRYSTEEL MANUFACTURING, INC.

P.O. Box 178 52182 Ember Road
Lake Crystal, MN 56055

1902 Route 57 South
Fulton, NY 13069

(507) 726-2728 (800) 533-0494