



Website: www.TBEI.com
E-mail: sales@TBEI.com

CRYSTEEL'S MARATHON TELESCOPIC HOIST



*THIS MANUAL MUST BE INCLUDED WITH THE VEHICLE
AFTER COMPLETING THE INSTALLATION.*

Web Site
www.crysteel.com

E-Mail
crysteel@tbei.com

Phone (507) 726-2728
Toll Free (800) 533-0494

DATE PURCHASED _____

BODY SERIAL NUMBER _____

CYLINDER SERIAL NUMBER _____

DEALER _____

ADDRESS _____

PHONE _____

FOREWORD

Crysteel's Marathon hoist is a heavy duty, front-mount telescopic hoist designed and intended for use under dump bodies. The Marathon hoist is available with either a single-acting or a double-acting cylinder. The Marathon hoist line consists of 8 sizes that fit single-, tandem- and triple-axle trucks with body lengths from 9 feet through 17 feet.

This manual contains the information needed for the proper installation and operation of Crysteel's Marathon hoist. Study it carefully before attempting to mount or use these products. With proper installation and maintenance, the Marathon Hoist and Crysteel Body will give many years of trouble-free service.

When ordering parts, be sure to give serial number of body and cylinder. The serial number of the body can be found low on the front of the body on the driver's side. The serial number of the cylinder is stamped on the barrel of the cylinder near the base. For future reference, copy these numbers NOW in the space provided above. Order parts by number and description as given in the parts listing in this manual.

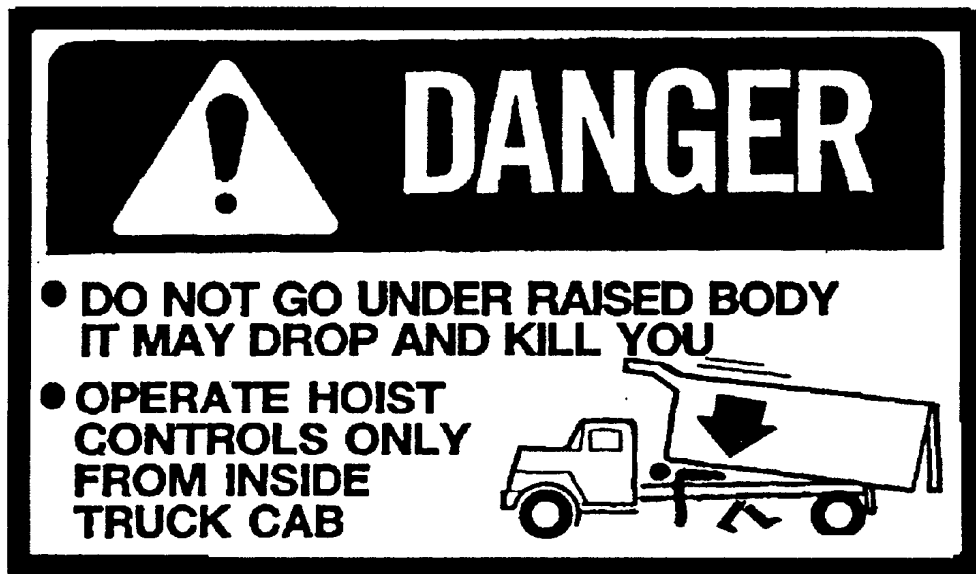

KEEP THIS MANUAL IN A SAFE PLACE FOR FUTURE REFERENCE

OPERATION AND USE

1. Engage PTO from cab and adjust engine speed to fast idle.
2. ALWAYS operate the hoist from inside the cab of the truck.
3. If the hydraulic hose connections are correct, the hoist should raise when the hoist control lever is pulled back, hold when the lever is in the center detent position, and lower when the lever is pushed forward.
4. To raise the hoist, pull the control lever back. To hold the body in a raised position, place the control lever in its center detent position. To lower the hoist, push the control lever forward.
5. ALWAYS return the hoist control lever to its center detent position after each use.
6. DO NOT LEAVE THE PTO IN GEAR WHILE TRANSPORTING. THIS CAN CAUSE SEVERE DAMAGE TO THE PTO OR HYDRAULIC PUMP.
7. To use the body prop(s), raise the body high enough to swing the body prop arms to their propping position. Raise the props and pin them in their propping position. Slowly lower the body onto the props.
8. To store the body prop(s), raise the body, lower the prop arms to their storage position, pin in place and lower the body.
9. The hydraulic system should be drained, flushed and refilled with proper hydraulic fluid at regular intervals. CAUTION: NEVER use hydraulic BRAKE FLUID in the hydraulic system.
10. After adding or replacing the hydraulic fluid, cycle the hoist several times to remove air from the cylinders and hydraulic hoses.

SOME DO'S AND DON'TS FOR SAFE AND LONG SERVICE

1. Use the proper hydraulic fluid. KEEP IT CLEAN. Remember to change it regularly.
2. Lubricate all grease fittings every 100 cycles or every two months. Infrequent or insufficient lubrication will cause hoist failure and possibly injury or death.
3. ALWAYS carefully block up the body, using the body prop, before working under it.
4. Do not "race" the engine when unloading.
5. Do not load the hoist beyond its capacity.
6. DO NOT tamper with the hydraulic relief valve. This will void the warranty. It can cause severe damage to the hoist and cylinder.
7. Never leave the PTO in gear while transporting. It could ruin the hydraulic pump, the PTO or the transmission.
8. Check all bolts and fittings regularly. Keep them tight. See table on page 4 for torque values.
9. Always operate hoist on a firm and level surface.
10. Always make sure area around truck is clear and safe for hoist operation and dumping.



TABLE OF CONTENTS

FOREWORD	2
SOME DO'S AND DON'TS FOR SAFE AND LONG SERVICE	3
OPERATION AND USE	3
GENERAL INFORMATION	5
LOCATE CYLINDER MOUNT AND REAR HINGE	6
INSTALL CYLINDER MOUNT	7
INSTALL REAR HINGE	8
INSTALL BODY/HOIST ASSEMBLY	8
MOUNT PUMP/VALVE - STANDARD	9
REVERSING PUMP ROTATION	9
SEPARATE VALVE & PUMP KIT	10
MOUNT PUMP - SEPARATE VALVE & PUMP KIT	10
MOUNT VALVE - SEPARATE VALVE & PUMP KIT	10
SEPARATE VALVE & PUMP KIT BLOCK DIAGRAM	10
MOUNT RESERVOIR	11
INSTALL VALVE CONTROL	11
INSTALL CYLINDER HOSES - DOUBLE ACTING	12
INSTALL CYLINDER HOSES - SINGLE ACTING	12
INSTALL RETURN AND SUCTION HOSES	13
INSTALL HOSES - SEPARATE VALVE & PUMP KIT	13
ADD HYDRAULIC OIL	14
MOUNT BODY	15
ALIGN HOIST CYLINDER AND WELD REAR HINGE	15
INSTALL BODY PROPS	16
FINISH WELDING BODY TO HOIST	17
BLEED TELESCOPIC CYLINDER	17
INSTALL CAB PROTECTOR	17
INSTALL GREASE ZERKS AND LUBRICATE	18
INSTALL LIGHTS, REFLECTORS AND DECALS	19
MARATHON HOIST PARTS	20
MARATHON HYDRAULIC SYSTEM PARTS	22

GENERAL INFORMATION

It is a good idea to look through these installation instructions before beginning to mount the hoist and hydraulic system.

When welding, protect the truck's electrical, air and brake systems by disconnecting, removing or covering. Tighten all nuts and bolts to a consistent level. Use the following table for torque values.

Size	Grade 2 Torque	Grade 5 Torque	Grade 8 Torque
			
1/4-20	3-4 lb-ft	6-7 lb-ft	10-11 lb-ft
1/4-28	4-5 lb-ft	8-9 lb-ft	11-12 lb-ft
5/16-18	8-9 lb-ft	14-15 lb-ft	21-22 lb-ft
5/16-24	9-10 lb-ft	15-16 lb-ft	21-22 lb-ft
3/8-16	17-18 lb-ft	24-26 lb-ft	37-40 lb-ft
3/8-24	19-20 lb-ft	28-30 lb-ft	40-43 lb-ft
1/2-13	38-42 lb-ft	60-65 lb-ft	90-100 lb-ft
1/2-20	43-47 lb-ft	70-75 lb-ft	95-105 lb-ft
5/8-11	75-80 lb-ft	122-130 lb-ft	180-190 lb-ft
5/8-18	85-90 lb-ft	145-150 lb-ft	200-210 lb-ft
3/4-10	132-140 lb-ft	220-230 lb-ft	315-330 lb-ft
3/4-16	152-160 lb-ft	250-260 lb-ft	355-370 lb-ft

The following abbreviations are used in describing hydraulic fittings.

ORBM	O-Ring Boss - Male Thread
NPTM	Pipe - Male Thread
NPTF	Pipe - Female Thread
JICM	JIC 37° - Male Thread
JICF	JIC 37° - Female Thread

INSTALLATION INSTRUCTIONS

LOCATE CYLINDER MOUNT AND REAR HINGE

The telescopic cylinder mount and the rear hinge must be located relative to each other according to the following chart. The chart shows the hoist model, recommended body length and CA or CT, the overhang, dump angle and mounting distance. The mounting distance is measured from the center of the rear hinge pin to the front of the body lift assembly.

The rear hinge must be located as close as possible behind the rear spring hanger. For single axle trucks this will be approximately 33 inches behind the rear axle and must never be more than 36 inches. For tandem axle trucks, this will be approximately 45 inches behind the center of the tandem, and must never be more than 50 inches. The telescopic cylinder mount should be located so there is at least 3" of clearance between the front of the body lift assembly and the back of the cab. See Fig. 1. (The lower cylinder mount extends past the front of the body 1 1/4".)

HOIST MODEL	BODY LENGTH	CA OR CT DIMENSIONS	OVERHANG	DUMP ANGLE	"D" DIM
M5390	10'	84" CA	6"	49°	114"
M5399	11'	96" CA	6"	51°	120"
M53117	12'	102" CA OR 96" CT	6"	55°	132"
	13'	108" CT	12"	50°	144"
M63138	14'	114" CT	12"	55°	156"
	15'	126" CT	12"	50°	168"
M63153	16'	138" CT	12"	52°	180"
	17'	150" CT	12"	49°	192"

- NOTE: 1. The "CA or CT Dimensions" and "Overhang" columns assume a cab clearance of 3" and a rear hinge dimension of 33" for single-axle trucks and 45" for tandem-axle trucks.
2. The front edge of the lift plates is even with the front of the body.

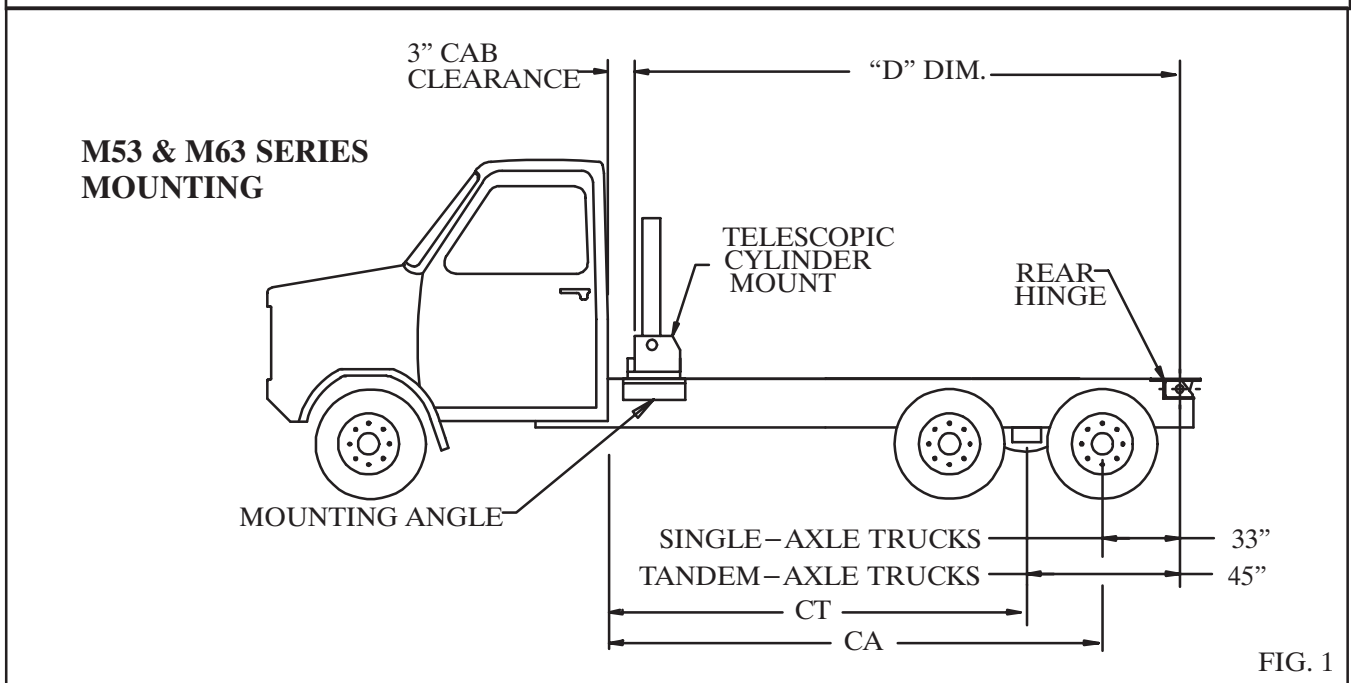

INSTALL CYLINDER MOUNT

Make sure the cylinder mount is correctly located (as determined by the previous instructions), centered, and square with the truck frame. If there are rivets or frame bolts in the way, holes can be drilled in the cylinder mount to allow it to sit flat on the truck frame. The mounting angles do not have predrilled holes in them to allow the use of existing holes in the truck frame. Clamp the mounting angles against the outside of the truck frame and against the bottom of the cylinder mount. (See Fig. 2.) Mark the location of the holes in the truck frame on the mounting angles. Remove the mounting angles and drill the holes in the locations marked.

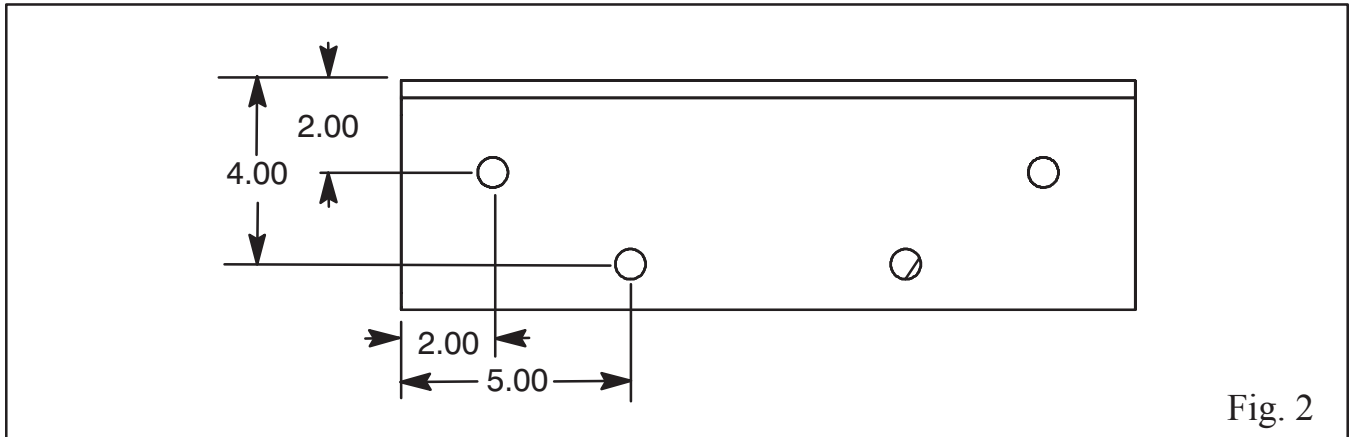

Bolt the mounting angles to the truck frame using the existing holes. The mounting angles must be attached to the truck frame with a minimum of four (4) 5/8" grade 8 cap screws. If the existing holes are not evenly spread over the whole length, additional holes should be drilled, spaced approximately as shown in Fig. 2.

CAUTION: BE CAREFUL OF BRAKELINES, WIRING, ETC. INSIDE THE TRUCK FRAME WHEN DRILLING THE TRUCK FRAME.

Drill 21/32" diameter holes in the mounting angles and truck frame and bolt the mounting angles in place using 5/8 x 2 cap screws (grade 8) and hex lock nuts. Tighten the cap screws to 180 to 190 lb-ft. Securely weld the cylinder mount to the mounting angles. **DO NOT** weld the cylinder mount to the truck frame. (See Fig. 3.)

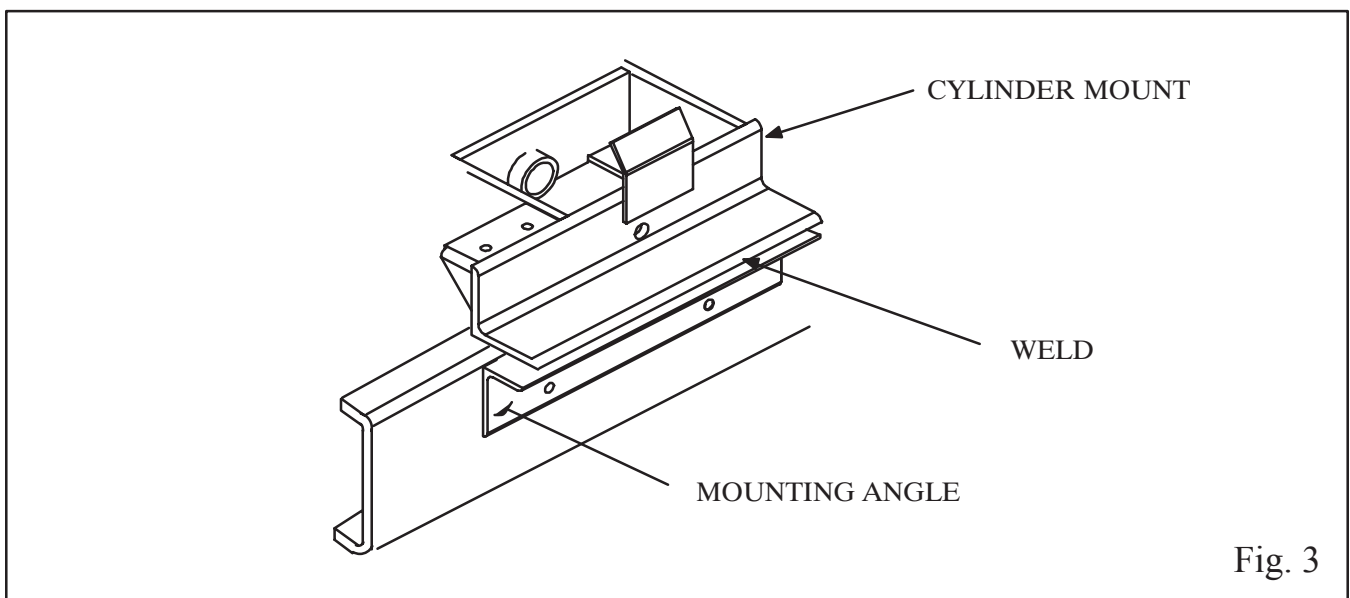

INSTALL REAR HINGE

If the front of the body longbeams are notched for the hoist, mount the rear hinge as shown in Fig. 4, style A. If the front of longbeams are not notched, use Fig. 4, style B. Notch the truck frame as shown in Fig. 4. Place the rear hinge on the truck frame. Make sure the rear hinge is correctly located, centered and square with the truck frame and the telescopic cylinder mount. Securely weld the rear hinge to the truck frame. Box the end of the truck frame with 1/4" thick plate (not supplied) and weld all around to the truck frame and rear hinge angle. Place the gussets in the corners formed by the truck frame rail and the rear hinge frame angle. Raise the front end of the gusset so it touches the top flange of the truck frame rail. Be sure that the gusset does not interfere with the rear hinge operation. Securely weld the gussets to the rear hinge, the truck frame rail and the top flange of the truck frame rail.

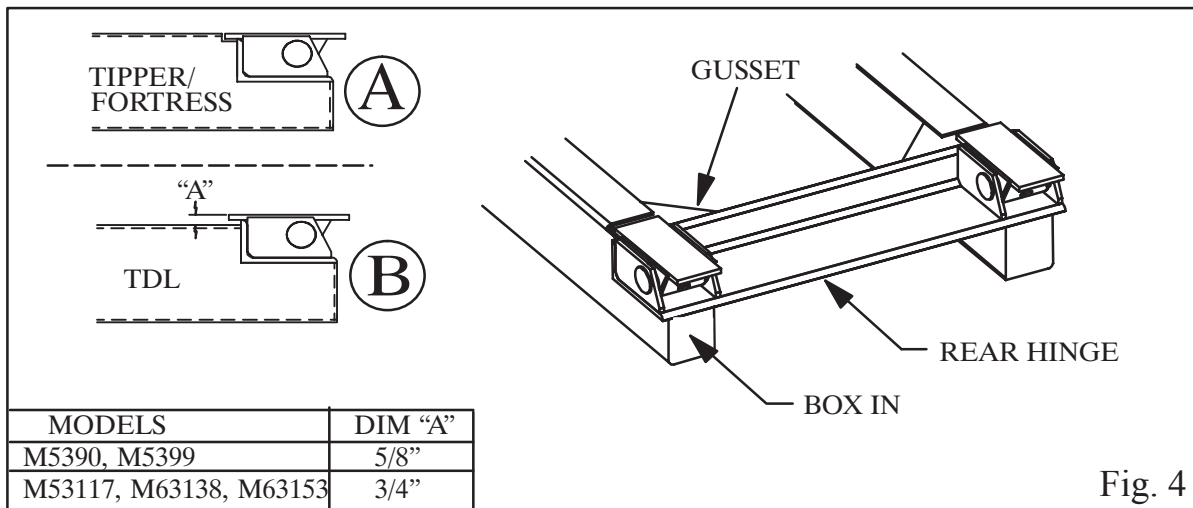

Fig. 4

NOTE: IT IS VERY IMPORTANT TO INSTALL THESE GUSSETS TO SECURELY MOUNT THE REAR HINGE TO THE TRUCK FRAME.

NOTE: If there are rivets on the top flange of the truck frame run a spacer the full length of the truck frame before mounting the telescopic cylinder mount or the rear hinge.

INSTALL BODY/HOIST ASSEMBLY

On some standard and custom bodies, the hoist is installed at the factory. This requires altering the installation procedures. Before placing the body/hoist assembly on the truck, install a male ORB x female NPT 90° swivel adapter in the power up port on the cylinder. For double-acting cylinders, install a 3/4 ORB male x 3/8 NPT female 90° swivel adapter in the power down port.

Place the body/hoist assembly on the truck frame with 3" of cab or exhaust clearance. Make sure the body and hoist assembly is correctly located, centered and square with the truck frame. Refer to the INSTALL CYLINDER MOUNT section above for installing the mounting angles.

If the longbeams are not notched to clear the hoist mount, rivet strips (not supplied) may be installed for supporting the longbeams. Weld them to the body longbeams.

MOUNT PUMP/VALVE - STANDARD

The standard pump/valve is intended to be mounted directly to a two-gear PTO with a direct mount flange. This saves time and effort and simplifies the installation. The pump has an SAE 'B' 4-bolt flange and a 13 tooth splined shaft. NOTE: This pump will mount directly to Chelsea's output type "XK" or Muncie's output type "D". Crysteel recommends a PTO ratio of 100 to 120%. This assures a minimum pump operating speed of 600 RPM. The pump is assembled with a counter-clockwise rotation when looking at the shaft end of the pump.

IMPORTANT: Before mounting the pump/valve, check the rotation of the PTO and make sure it matches the rotation of the pump. If it is opposite, the pump rotation will have to be reversed. To reverse the pump rotation, follow the pump reversing procedure below. Make sure the pump has plenty of clearance and that the hoses are kept clear of hot mufflers and exhaust pipes.

IMPORTANT: The C102D pump/valve supplied for the M5399 through M63153 can be mounted directly to a PTO but **MUST** be supported externally to the transmission. Long mounting studs and extra nuts are provided with each unit for this purpose.

REVERSING PUMP ROTATION

The pump is assembled with a counter-clockwise rotation when looking at the shaft end of the pump. (Looking at the shaft end of the pump with the drive shaft on top and the idler gear on the bottom, the valve spool will be on the left side. See Fig. 5.) If the pump needs to rotate in the opposite direction, then follow these steps to reverse the pump:

1. Remove the four 9/16-12 capscrews holding the pump together.
2. CAREFULLY remove the valve body assembly from the pump.
3. CAREFULLY remove the gear housing. Rotate the housing 180° and replace it. The drive shaft gear bore becomes the idler gear bore.
4. Rotate the valve body 180° from its original position and replace it.
5. Replace the four 9/16-12 capscrews and torque to 2400 in-lbs.
6. To verify that the pump is now assembled for clockwise rotation, look at the shaft end of the pump with the drive shaft on the top and the idler gear on the bottom, the valve spool will be on the right side. (See Fig. 6.)
7. Fill the suction port with hydraulic oil and rotate shaft to fill the gears with oil.

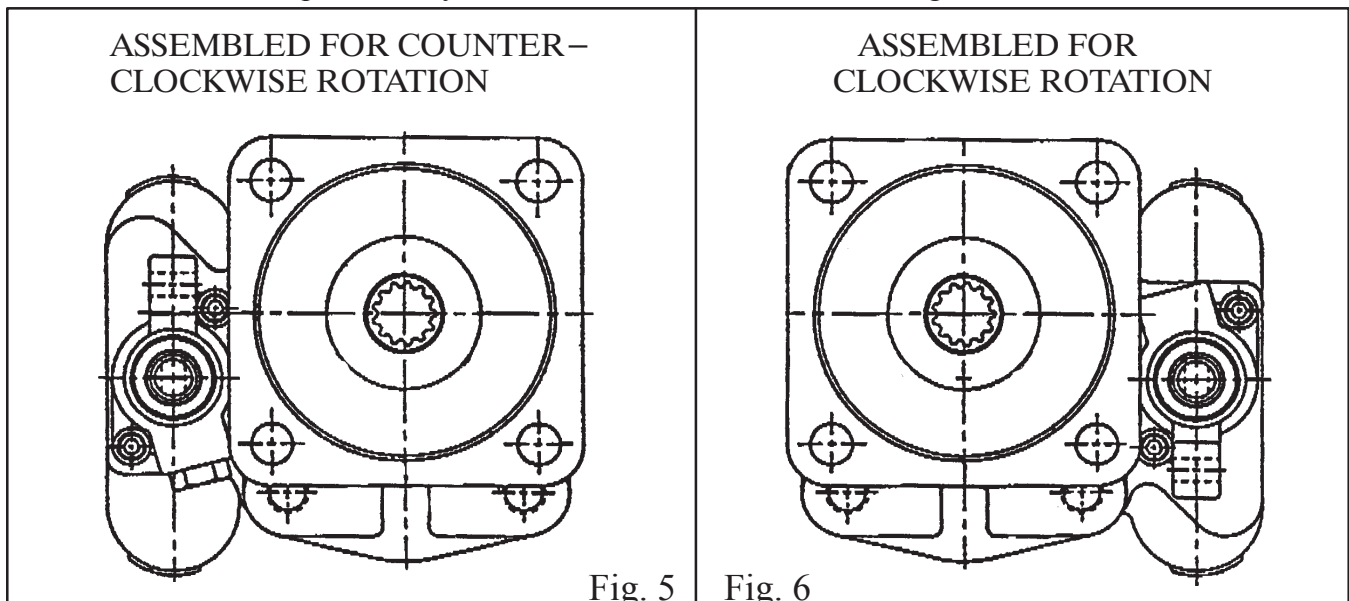

SEPARATE VALVE & PUMP KIT

On trucks where the combination pump/valve does not fit, a hydraulic kit with a separate valve and pump is available. The pump in this kit is double-rotation; it works whether driven clockwise or counter-clockwise. This kit contains a bracket for mounting the valve to the truck frame.

MOUNT PUMP - SEPARATE VALVE & PUMP KIT

The separate pump is intended to be mounted directly to a two-gear PTO with a direct mount flange. The pump has an SAE 'B' 4-bolt flange and a 13 tooth splined shaft.

NOTE: This pump will mount directly to Chelsea's output type "XK" or Muncie's output type "D". Crys-teel recommends a PTO ratio of 100-120%. This assures a minimum pump operating speed of 600 RPM. Make sure the pump has plenty of clearance and that the hoses are kept clear of hot exhaust systems.

MOUNT VALVE - SEPARATE VALVE & PUMP KIT

The valve mounting bracket is intended to be mounted to the inside of the truck frame on the driver's side. Bolt the valve to the bracket using cap screws and hex lock nuts. Determine where to mount the valve and mark the truck frame for drilling using the mounting bracket as a guide. Drill 13/32" diameter holes in the truck frame. (See caution note below.) Bolt the bracket to the truck frame using 3/8 x 1 1/2 cap screws and hex lock nuts.

CAUTION:
BE CAREFUL OF
BRAKELINES,
WIRING, ETC. INSIDE
THE TRUCK FRAME
WHEN DRILLING THE
TRUCK FRAME.

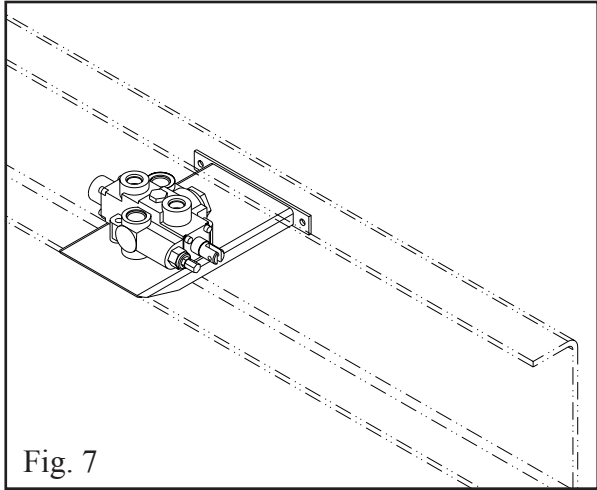

Fig. 7

SEPARATE VALVE & PUMP KIT BLOCK DIAGRAM

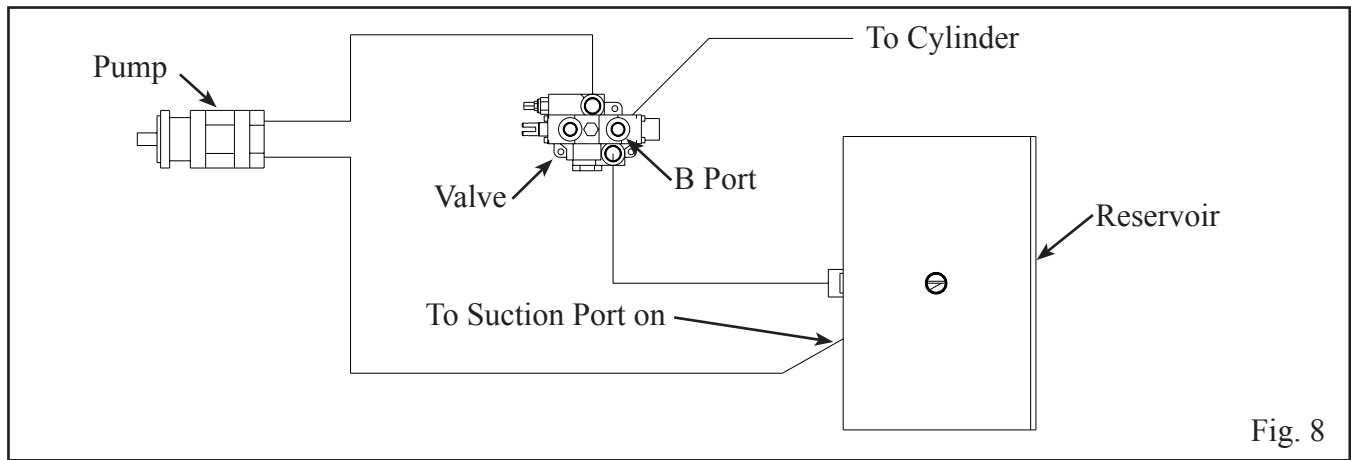

Fig. 8

MOUNT RESERVOIR

Determine on which side of the truck to mount the reservoir. There are four ports on the reservoir - a fill port on the top, a 2" NPT suction port on the bottom, a 1 1/4" NPT return port near the bottom on one side and one smaller port near the top on one side for a sight glass. Clamp the reservoir mounting brackets to the sides of the reservoir and place the reservoir against the outside of the truck frame. (See Fig. 7.) Mark the truck frame for drilling using the mounting brackets as guides.

CAUTION: BE CAREFUL OF BRAKELINES, WIRING, ETC. INSIDE THE TRUCK FRAME WHEN DRILLING THE TRUCK FRAME.

Drill 17/32" holes in the truck frame and bolt the mounting brackets in place using 1/2 x 2 grade 8 cap screws and hex lock nuts, tightening to 90 to 100 lb-ft. Securely weld the reservoir to the reservoir mounting brackets. Install the sight glass in the port provided.

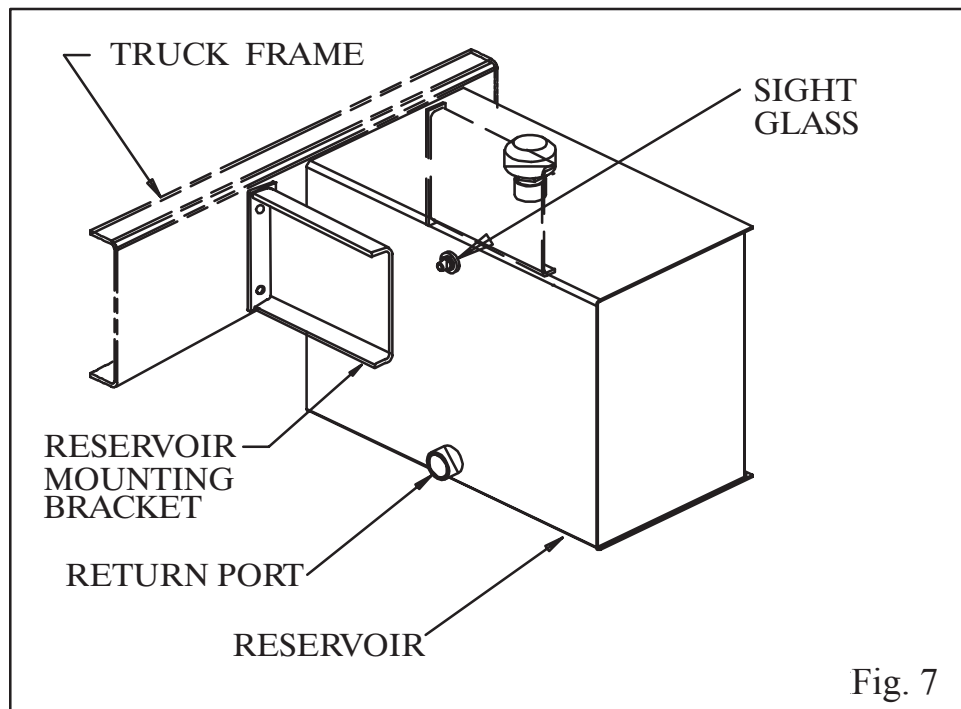

INSTALL VALVE CONTROL

Place the control pedestal assembly on the floor of the cab in a convenient location next to the drivers seat. Mark the floor using the pedestal as a template and drill 5/16 inch holes for the mounting screws and a 3/4 inch hole for the control cable. (Check below the floor for obstructions and cable routing before drilling.)

Assemble the control cable to the valve control. Bolt the valve control to the pedestal using 1/4 x 1/2 machine screws. Install the cover on the side of the pedestal using 1/4 x 1/2 machine screws. Mount the pedestal to the floor using 5/16 x 1/2 cap screws and hex lock nuts. Connect the other end of the cable to the control valve using the parts and instructions in the valve connection kit. (See Fig. 8.) NOTE: The two spool seal retaining plates on the 'G' series double-acting pump/valves must remain installed on the

pump/valve. If they are removed, oil can be pumped past the spool into the control cable and into the cab of the truck.

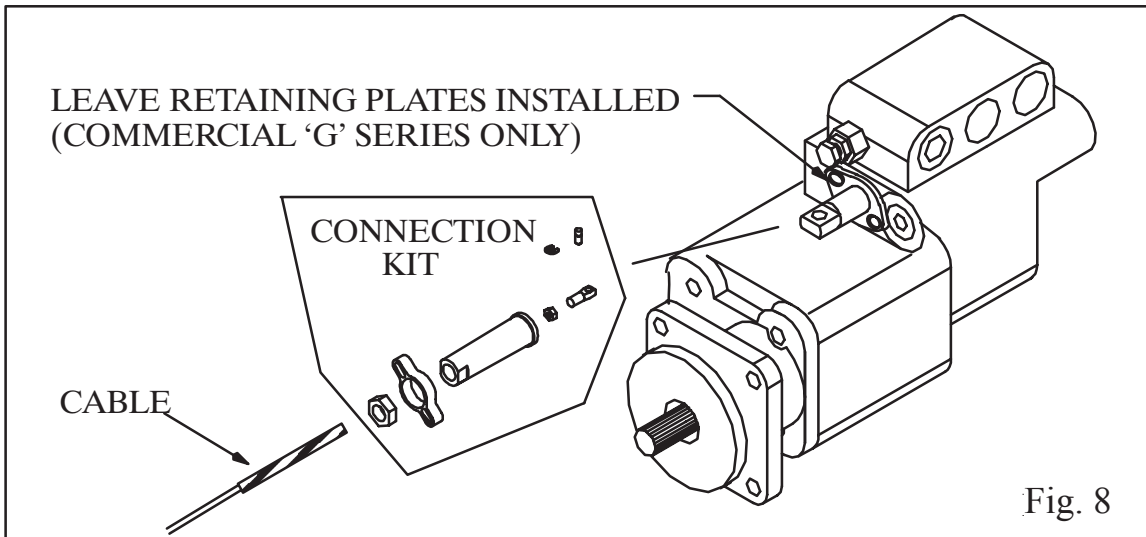

INSTALL CYLINDER HOSES - DOUBLE ACTING

For M53 series, install a 1 1/16 ORB male x 3/4 NPT female 90° swivel adapter in the power-up port on the cylinder. For M63 series, install a 1 1/16 ORB male x 1 NPT female 90° swivel adapter in the power-up port on the cylinder. Install a 3/4 ORB male x 3/8 NPT female 90° swivel adapter in the power-down port.

For M53 series, install a 1 1/16 ORB x 3/4 NPT 90° swivel adapter in the B (power up) port of the control valve. For M63 series, install a 1 1/16 ORB x 1 NPT 90° swivel adapter in the B (power up) port of the control valve. Install a 1 1/16 ORB x 3/4 ORB extension and a 3/4 ORB x 3/8 NPT 90° swivel adapter in the A (power down) port. Using a 60" long hose, connect the B port on the control valve to the power up port on the cylinder. Using a 60" long 3/8" I.D. hose, connect the A port to the power down port. This will raise the body when the valve control lever is pulled back and lower the body when the lever is pushed forward.

INSTALL CYLINDER HOSES - SINGLE ACTING

For M53 series, install a 1 1/16 ORB male x 3/4 NPT female 90° swivel adapter in the port on the cylinder. Install a 1 1/16 ORB x 3/4 NPT swivel adapter in the work port of the control valve. Using a 60" long hose, connect the work port of the control valve to the port on the telescopic cylinder.

For M63 and M74 series, install a 1 5/16 ORB male x 1 NPT female 90° swivel adapter in the port on the cylinder. Using a 60" long hose, connect the work port of the control valve to the port on the telescopic cylinder.

INSTALL RETURN AND SUCTION HOSES

A return line hose must be installed for long pump life. A suction port sleeve has been installed in the suction port on the pump. (See Fig. 8.) This sleeve prevents the oil from recirculating inside the pump/valve and directs the oil flow out the return port. Operating this pump/valve without installing the return line will cause the pump/valve to fail.

For M53 series, install a 1 1/4 x 1 hex reducing bushing in the return port on the reservoir. Remove the plug from the return port on the control valve and install a swivel adapter in its place. Install a 72" long hose from the return port on the pump to the return port on the reservoir.

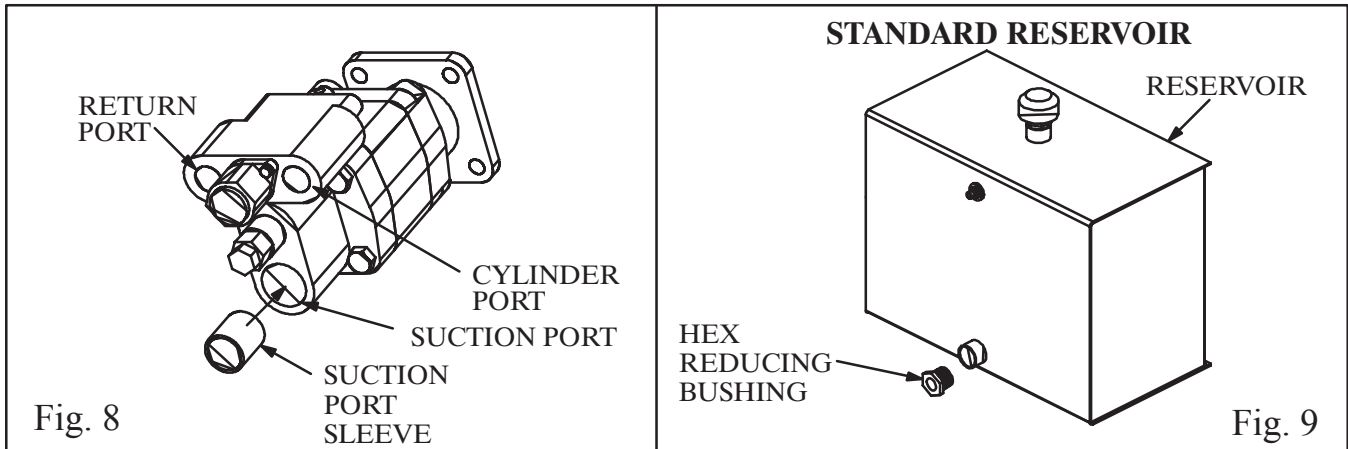

Install the 2" NPT x 1 1/2" hose barb in the suction port on the bottom of the frame-mounted reservoir and the 1 1/4" NPT x 1 1/2" hose barb in the suction port on the back of the pump/valve. Connect a 1 1/2" I.D. suction hose from the reservoir to the pump and secure it with hose clamps.

INSTALL HOSES - SEPARATE VALVE & PUMP KIT

The separate valve & pump kit requires four hoses to be installed - 1) from the valve to the cylinder, 2) from the reservoir to the pump, 3) from the pump to the valve and 4) from the valve to the reservoir. See the block diagram on page 10.

Determine which port on the pump is the suction port. Install a hose barb in this port. Install a straight adapter in the other port. Install a hose barb in the suction port on the bottom of the reservoir. Connect the two hose bars with the suction hose provided and secure it with hose clamps.

Install 90° adapters in the IN, OUT and B ports on the valve. For T53 series hoists, connect a 3/4" hose from the pressure port on the pump to the IN port on the valve, a 3/4" hose from the valve to the cylinder and a 1" hose from the OUT port on the valve to the return port on the side of the reservoir.

For T63, T73 and T74 series hoists, connect a 1" hose from the pressure port on the pump to the IN port on the valve, a 1" hose from the valve to the cylinder and a 1 1/4" hose from the OUT port on the valve to the return port on the side of the reservoir.

ADD HYDRAULIC OIL

Use a quality hydraulic fluid of 150 SSU @ 100°F which contains corrosion and oxidation inhibitors and a foam depressant (ISO 32 grade). This is approximately the equivalent of SAE 10W or lighter weight oil. Initially fill the reservoir with the quantities given below. After bleeding the air from the cylinder, refill the reservoir to the sight glass level. DO NOT OVERFILL THE RESERVOIR!

KEEP THE OIL CLEAN. USE CLEAN CONTAINERS, FUNNELS AND OTHER EQUIPMENT!

HOIST MODEL	RESERVOIR SIZE	INITIAL FILL AMOUNT	CYLINDER DISPLACEMENT
M5390	16 Gal.	12 Gal.	6.5 Gal.
M5399	16 Gal.	12 Gal.	7.1 Gal.
M53117	23 Gal.	16 Gal.	8.4 Gal.
M63117	28 Gal.	21 Gal.	12.3 Gal.
M63138	28 Gal.	21 Gal.	14.6 Gal.
M63153	28 Gal.	21 Gal.	16.1 Gal.

Use a quality hydraulic fluid of 150 SSU @ 100°F which contains corrosion and oxidation inhibitors and a foam depressant (ISO 32 grade). This is approximately the equivalent of SAE 10W or lighter weight oil. Initially fill the reservoir with the quantities given below. After bleeding the air from the cylinder, refill the reservoir to the sight glass level. DO NOT OVERFILL THE RESERVOIR!

NOTE: If the pump does not pump oil, pressurize the reservoir and engage the pump with the engine at slow idle. Once the pump is working, release the pressure and install the breather cap.

With normal use and working conditions the hydraulic oil should be changed annually. The breather cap should be cleaned every time the hydraulic oil is changed. With heavy use or very dusty working conditions the hydraulic oil should be changed more often.

MOUNT BODY

Place the body on the truck with 3” cab clearance for M53 and M63 hoists. Slide the body back until the front panel contacts the upper lift of the cylinder mount. Securely weld the body longbeams to the outside edge of the upper lift of the telescopic cylinder mount on both sides of the truck. (See Fig. 10.)

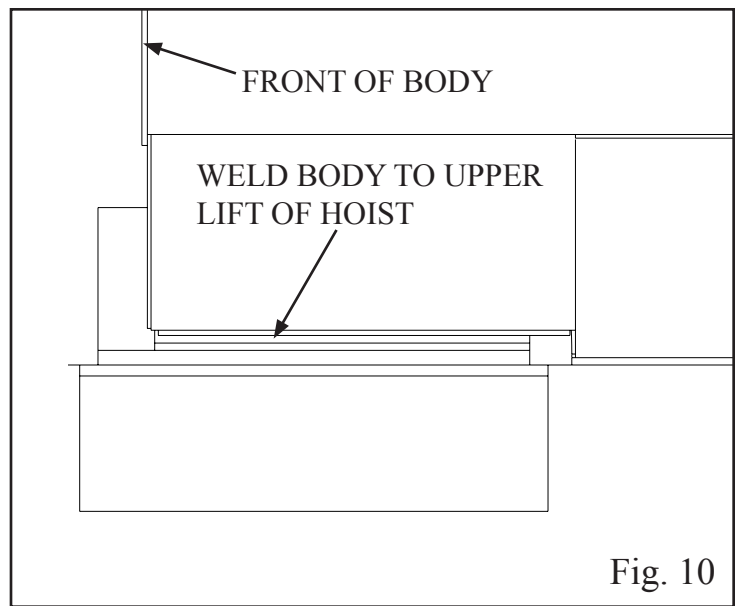

DO NOT WORK UNDER A RAISED BODY UNLESS THE BODY IS SECURELY BLOCKED OR PROPPED IN THE RAISED POSITION.

ALIGN HOIST CYLINDER AND WELD REAR HINGE

The entire body and body lift assembly can now be moved slightly forward or rearward to align the cylinder in the doghouse. Make certain that the cylinder is vertical and is not leaning to the front or to the rear. Weld the body longbeams very securely to the rear hinge plates. (See Fig. 11.)

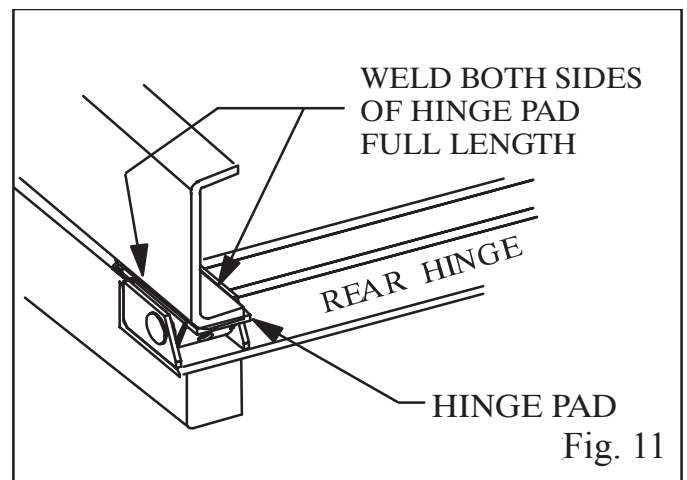

DO NOT WORK UNDER A RAISED BODY UNLESS THE BODY IS SECURELY BLOCKED OR PROPPED IN THE RAISED POSITION.

INSTALL BODY PROPS

The body prop is designed and intended to support an EMPTY truck body in the raised position. Use of the body prop permits service to be performed safely beneath a raised body. One body prop is included with Marathon Hoist models M5390 and M5399; two body props (one pair) are included with models M53117 through M63153. Be sure to install each prop on the correct side of the truck as explained below and shown in Fig. 12.

1. Raise the body to a 30° to 35° angle and brace it securely before beginning installation.
2. Assemble the prop arm to the prop pivot mount with a 1/4 x 3 roll pin. Clamp the prop pivot mount against the outside of the truck frame just behind the rear axle. Raise the body prop arm to a free standing position. Place the body prop bracket in the prop arm saddle. Reposition if needed to locate the prop bracket on the longbeam. It may be necessary to raise or lower the body to get the best location for the prop pivot mount. Using the prop pivot mount as a guide, mark the location of holes on the truck frame and drill 17/32 inch holes. Assemble the prop pivot mount to the frame using 1/2 x 2 cap screws, and hex lock nuts, tightening to 90 to 100 lb-ft. Raise the prop arm to a free standing position, place the body prop bracket in the saddle and securely weld the bracket to the longbeam.

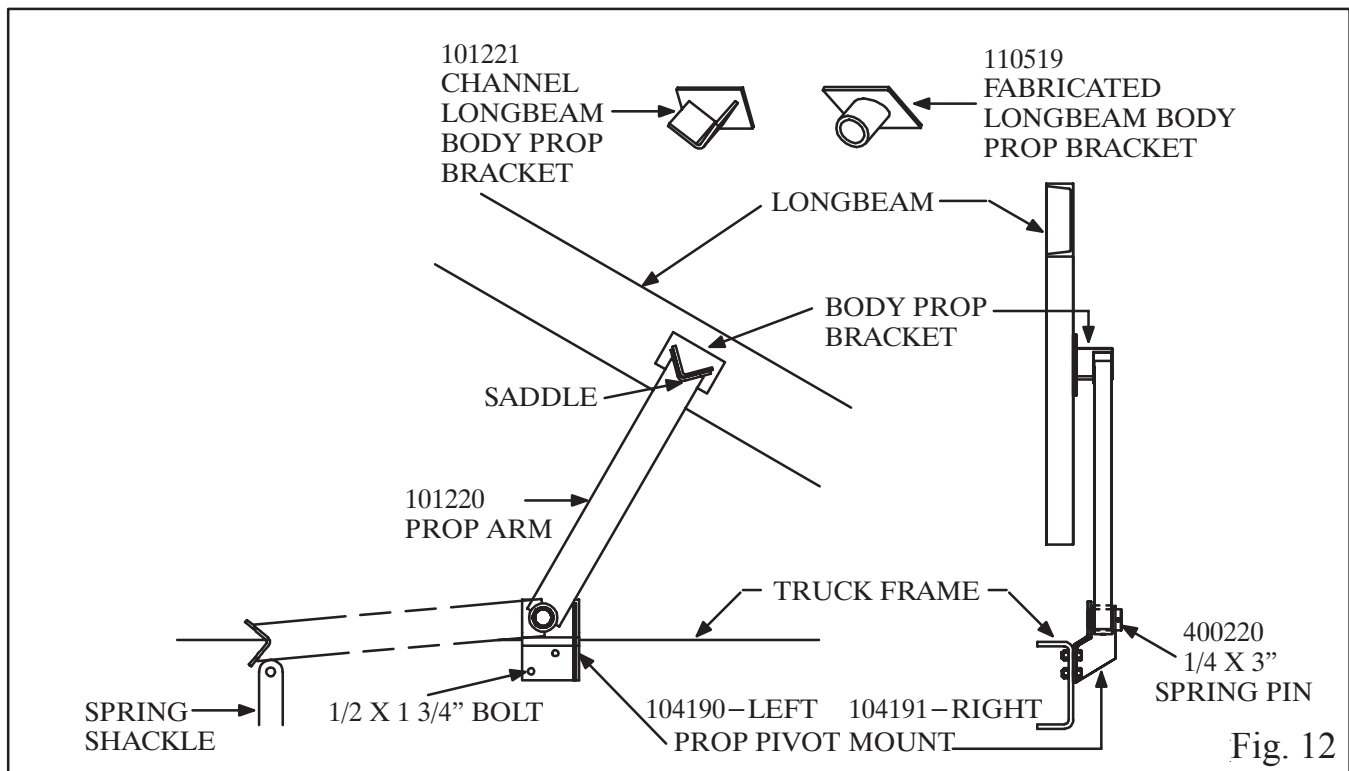

3. When mounting two body props, repeat steps 1 and 2 for the other side. Use the body prop already mounted to assure that both body props hold the body at the same height. The left and right body props should pivot toward the front of the truck in the storage position.
4. To operate the body prop, raise the body to the desired height, shut off all power, raise the prop arm to a free standing position. Lower the body slowly until the body prop bracket contacts the prop arm saddle.
5. To place the body prop in the storage position, raise the body to clear the body prop saddle, lower the body prop to the storage position and lower the body.

***DO NOT WORK UNDER A RAISED BODY UNLESS THE BODY IS SECURELY
BLOCKED OR PROPPED IN THE RAISED POSITION.***

FINISH WELDING BODY TO HOIST

After the body props have been installed, raise the body to rest on the props. Finish welding the upper lift of the telescopic cylinder mount to the inside of the body longbeams. Securely weld the upper lift to the body longbeams the full height of the upper lift on both the front and back sides of the upper lift. Also weld the bottom edge of the front panel to the upper lift. (See Fig. 13.)

If the body and hoist have been assembled at the factory, finish welding the hoist lift brackets to the fill plates on the inside of the longbeams.

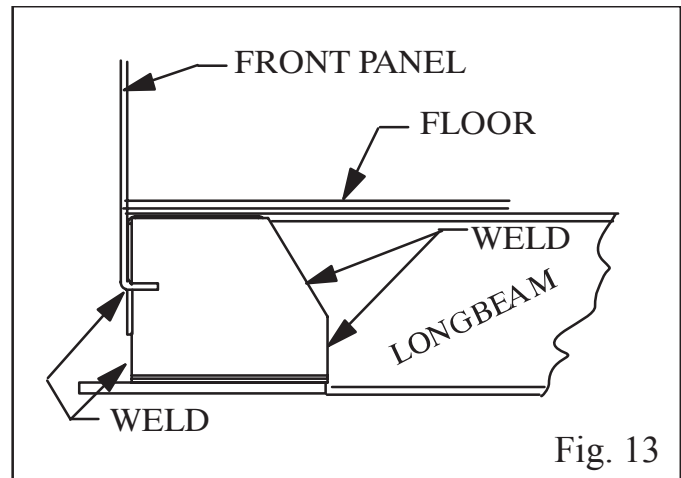

Fig. 13

BLEED TELESCOPIC CYLINDER

All of the air must be removed from the cylinder for smooth and safe operation of the hoist. All M-Series single-acting cylinders are equipped with a self-bleeding feature. To bleed the air from these models, raise and lower the hoist two or three times to remove the air.

After bleeding the cylinder, check the oil level in the reservoir. There should be 2 or more inches of oil in the bottom of the reservoir when the body is raised to its full height. When the body is down, oil should be visible in the sight glass.

***DO NOT WORK UNDER A RAISED BODY UNLESS THE BODY IS SECURELY
BLOCKED OR PROPPED IN THE RAISED POSITION.***

INSTALL CAB PROTECTOR

If a cab protector is to be installed on the front of the dump body, it must be notched to fit around the “doghouse”. This is because the top of the cylinder swings forward out of the doghouse in the body as the body is raised and severe damage would occur if the cylinder were trapped by the cab protector.

INSTALL GREASE ZERKS AND LUBRICATE

Install grease zerks in the body props. Lubricate all fittings at regular intervals, at least every 150 cycles or every two months. The grease fittings are located as follows:

A. Rear Hinge	2 fittings (Installed)
B. Latch Lever of Air Tailgate Latch Mount	1 fitting
C. Tailgate Latch Pivot	2 fittings
D. Tailgate Hinge Pivot	2 fittings
E. Cylinder Top Pivot	1 fitting under doghouse cover
F. Cylinder Lower Pivot	1 fitting

NOTE: The hoist cylinder pivots, both truck mount and body mount, do not require lubrication. These pivot points are equipped with self-lubricating composite bearings that do not need lubrication. If they are ever disassembled (to repair or replace the cylinder), care must be used to avoid damage to the composite bearings.

INSTALL LIGHTS, REFLECTORS AND DECALS

Install the lights and wiring harness. Mount the amber reflectors near the front on the sides. Mount the red reflectors near the rear on the sides and on the tailgate near the sides. Slip the rubber hand grip over the end of the latch control lever. MOUNT DECALS IN THE PROPER PLACES. See Fig. 14 for decal identification and placement.

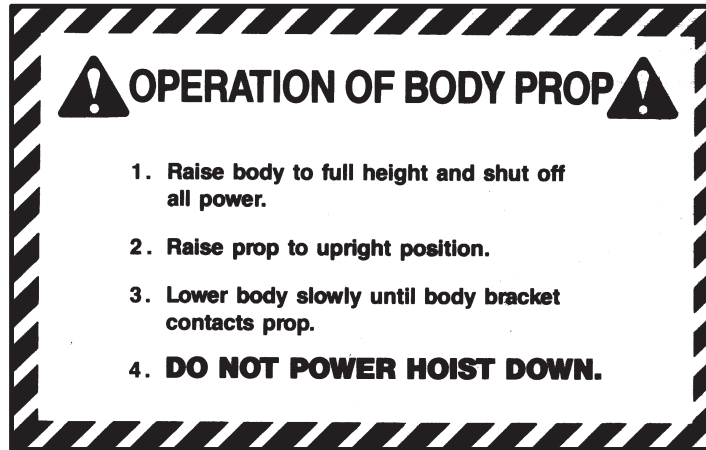

1642848 – Mount on the body longbeam near the body prop

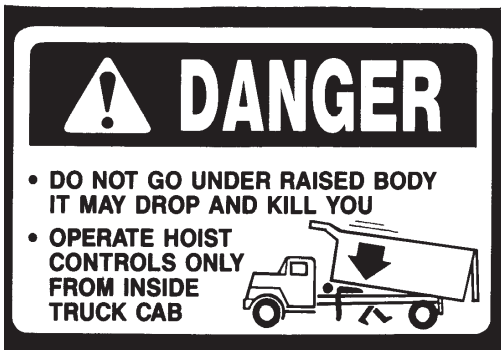

1643067 – Mount on the outside of the body longbeams near the front of the body (one on each side).



1642844 – Mount on the longbeam on the drivers side.

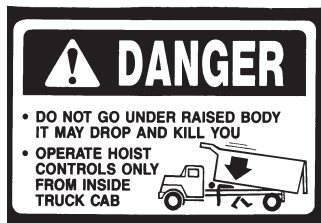

1643068 – Mount in the cab in a prominent location



1642843 – Mount in the cab in a prominent location'



1642846 – Mount on the body prop arm.

Fig. 14

MARATHON HOIST PARTS

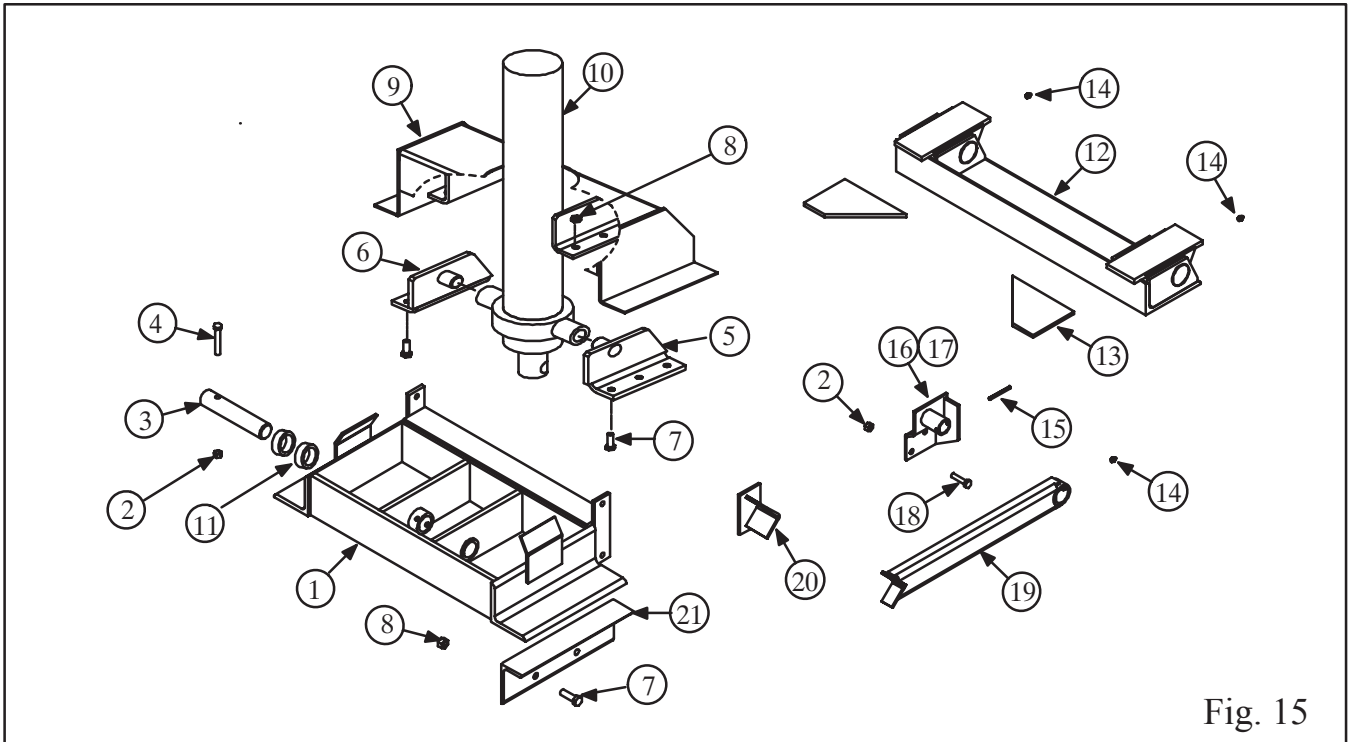

ITEM	DESCRIPTION	MODELS	SYTELINE	QTY
1.	Assy Lower Mount	M5390-M5399 M53117 M63117-M63153	1621629 1621630 1623262	1
2.	Hex Lock Nut 1/2-13	All	1642984	5
3.	Pin Hoist Pivot	M5390-M53117 M63138-M63153	1629891 1631931	1
4.	Cap Screw 1/2-13 x 3 1/4 HH	All	1642944	1
5.	Assy Upper Pivot - LH	All	1625138	1
6.	Assy Upper Pivot - RH	All	1625139	1
7.	Cap Screw 5/8-11 x 2 HH	All	1643313	14
8.	Hex Lock Nut 5/8-11	All	1643070	14
9.	Assy Upper Lift	All	1625137	1
10.	Assy Cylinder - SA	M5390 M5399 M53117 M63117 M63138 M63153	1424301 1424302 1424303 1424304 1424305 1424306	1
	Assy Cylinder - DA	M5390 M5399 M53117 M63117 M63138 M63153	1643447 1643448 1643449 1644823 1644127 1644128	1

ITEM	DESCRIPTION	MODELS	SYTELINE	QTY
11.	Spacer Lower - M53	M5390-M53117 M63138-M63153	1630017 Not Req'd	2
12.	Assy Rear Hinge	M5390-M5399 M53117-M63153	1272598 1283750	1
13.	Gusset Rear Hinge	All	1629894	2
14.	Grease Zerk 1/8 NPT Straight	All	1642699	4
15.	Spring Pin 1/4 x 3	M5390-M5399 M53117-M63153	1642757	1 2
16.	Assy Prop Pivot - LH	All	1621523	1
17.	Assy Prop Pivot - RH	M53117-M63153	1621524	1
18.	Cap Screw 1/2-13 x 2 HH	M5390-M5399 M53117-M63153	1642701	2 4
19.	Assy Body Prop Arm	M5390-M5399 M53117-M63153	1621500	1 2
20.	Assy Prop Bracket	M5390-M5399 M53117-M63153	1622175	1 2
21.	Angle Mounting - 16" Lg	All	1643297	2
22.	Seal Kit	M5390-M53117 M63117-M63153	1643457 1643458	1

NOTES

MARATHON HYDRAULIC SYSTEM PARTS

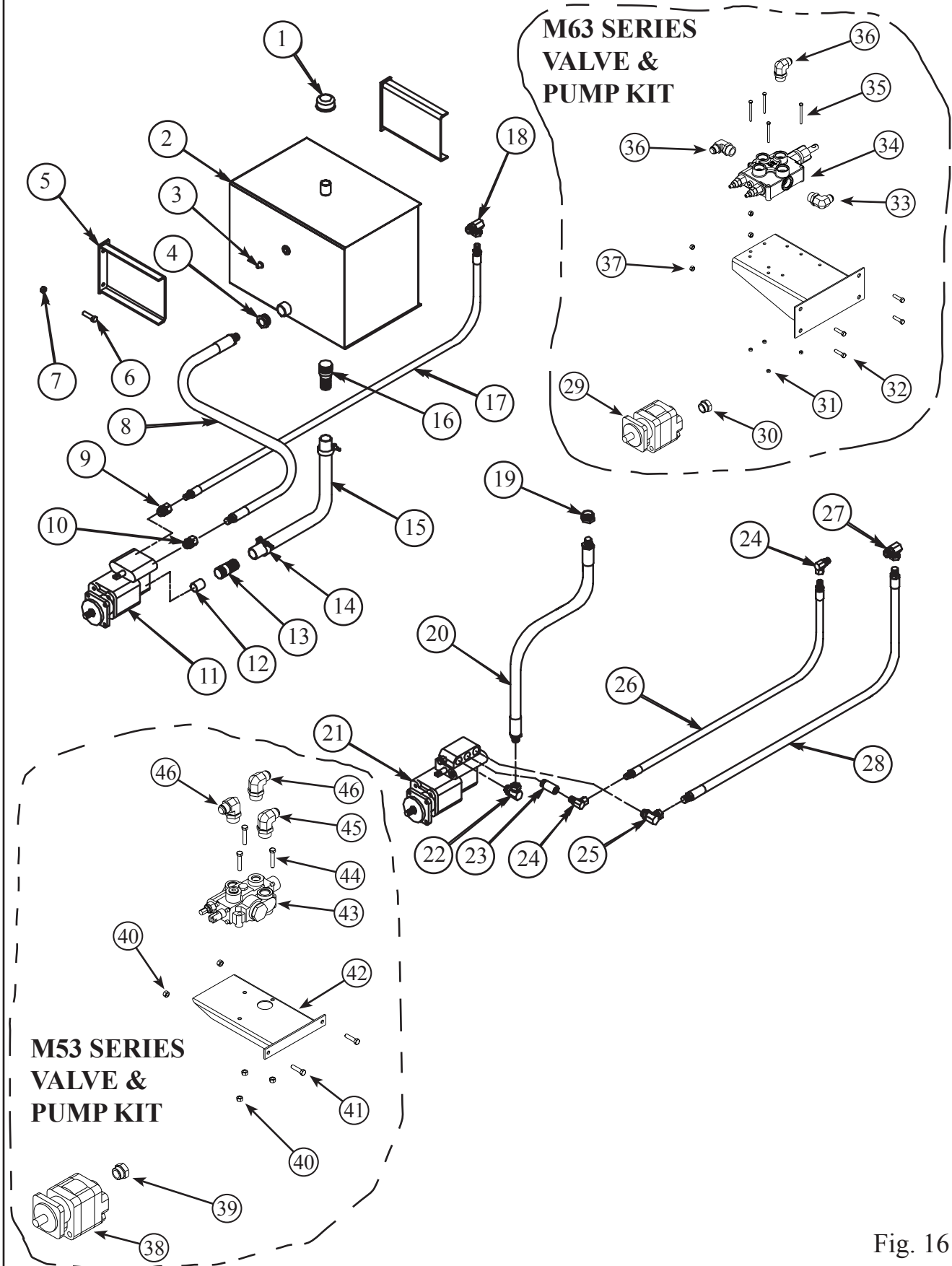

**M63 SERIES
VALVE &
PUMP KIT**

**M53 SERIES
VALVE &
PUMP KIT**

Fig. 16

ITEM	DESCRIPTION	MODELS	PART NO.	QTY
1.	Breather Cap	All	1644723	1
2.	Reservoir Assy 16 Gal	M53	1621834	1
	28 Gal	M63	1621836	1
3.	Sight Glass	All	1332917	1
4.	Bushing Hex Reducing 1 1/4 x 1	M53 M63	1643808 Not Req'd	1
5.	Mounting Bracket	All	1622224	2
6.	Cap Screw 1/2-13 x 2 HH	All	1642701	4
7.	Hex Lock Nut 1/2-13	All	1642984	4
12.	Suction Port Sleeve	All	1643055	1
13.	Hose Barb 1 1/4 NPT x 1 1/2"	All	1643118	1
14.	Hose Clamp 2"	All	1643240	2
15.	Suction Hose 1 1/2" ID x 72" Lg	All	1643119	1
16.	Hose Barb 2 NPT x 1 1/2"	All	1643117	1
17.	Hose 3/4 NPT x 60" Lg	M53	1643062	1
	1 NPT x 60" Lg	M63	1643803	1
18.	Adapter 1 1/16 ORB x 3/4 NPT 90°	M53	1642971	1
	Adapter 1 5/16 ORB x 1 NPT 90°	M63	1643802	
19.	Bushing Hex Reducing 1 1/4 x 1	M53 DA	1643020	1
	1 1/4 x 1	M63 DA	1643808	1
20.	Hose 3/4 NPT x 72" Lg	M53 DA	1643165	1
	1 NPT x 72" Lg	M63 DA	1643166	1
21.	Pump / Valve - Double-Acting DA 15 GPM 'G' Series	M5390-M63153	1643851	1
22.	Adapter 1 1/16 ORB x 3/4 NPT 90°	M53 DA	1642971	1
	Adapter 1 1/16 ORB x 1 NPT 90°	M63 DA	1643751	1
23.	Extension 1 1/16 ORB x 3/4 ORB	All DA	1630381	1
24.	Adapter 3/4 ORB x 3/8 NPT 90°	All DA	1642953	2
25.	Adapter 1 1/16 ORB x 3/4 NPT 90°	M53 DA	1642971	1
	Adapter 1 1/16 ORB x 1 NPT 90°	M63 DA	1643751	1
26.	Hose 3/8 NPT x 60" Lg	All DA	1643063	1
27.	Adapter 1 1/16 ORB x 3/4 NPT 90°	M53 DA	1642971	1
	Adapter 1 5/16 ORB x 1 NPT 90°	M63 DA	1643802	1
28.	Hose 3/4 NPT x 60" Lg	M53 DA	1643062	1
	1 NPT x 60" Lg	M63 DA	1643803	1
29.	Gear Pump 25 GPM DM 'B' Mounting	M63	1644754	1
30.	Adapter 1 5/8 ORBM x 1 NPTF, Swivel	M63	1643167	1
31.	Hex Lock Nut 1/4-20	M63	1643315	4
32.	Cap Screw, Hex Hd - 3/8-16 x 1 1/2 Gr 8	M63	1642710	4
33.	Adapter 1 5/16 ORBM x 1 1/4 NPTF 90°	M63	1644193	1
34.	Control Valve 50 GPM SA 2500 PSI	M63 SA M63 DA	1645003 1645002	1 1

ITEM	DESCRIPTION	MODELS	PART NO.	QTY
35.	Cap Screw, Hex Hd - 1/4-20 x 3 Gr 5	M63	1644809	4
36.	Adapter 1 5/16 ORBM x 1 NPTF 90°	M63	1643802	2
	Adapter 1 5/16 ORBM x 1 NPTF	M63 DA	1643401	1
	Adapter 1 1/16 ORBM x 1/2 NPTF 90°		1642969	1
37.	Hex Lock Nut 3/8-16	M63	1643177	4
38.	Gear Pump 15 GPM DM 'B' Mounting	M53	1644776	1
39.	Adapter 1 1/16 ORBM x 3/4 NPTF	M53	1630637	1
40.	Hex Lock Nut 3/8-16	M53	1643177	5
41.	Cap Screw, Hex Hd - 3/8-16 x 1 1/2 Gr 8	M53	1642710	2
42.	Assy Valve Mount - Prince	M53	1621637	1
43.	Control Valve 30 GPM SA 2500 PSI	M53 SA	1643541	1
	Control Valve 30 GPM DA 2500 PSI	M53 DA	1643759	1
44.	Cap Screw, Hex Hd - 3/8-16 x 2 Gr 8	M53	1643202	3
45.	Adapter 1 1/16 ORBM x 1 NPTF 90°	M53	1643751	1
46.	Adapter 1 1/16 ORBM x 3/4 NPTF 90°	M53	1642971	2
	Adapter 1 1/16 ORBM x 3/4 NPTF	M53 DA	1631074	1
	Adapter 3/4 ORBM x 3/8 NPTF 90°		1642953	1

NOTES

HOIST CONTROL PARTS

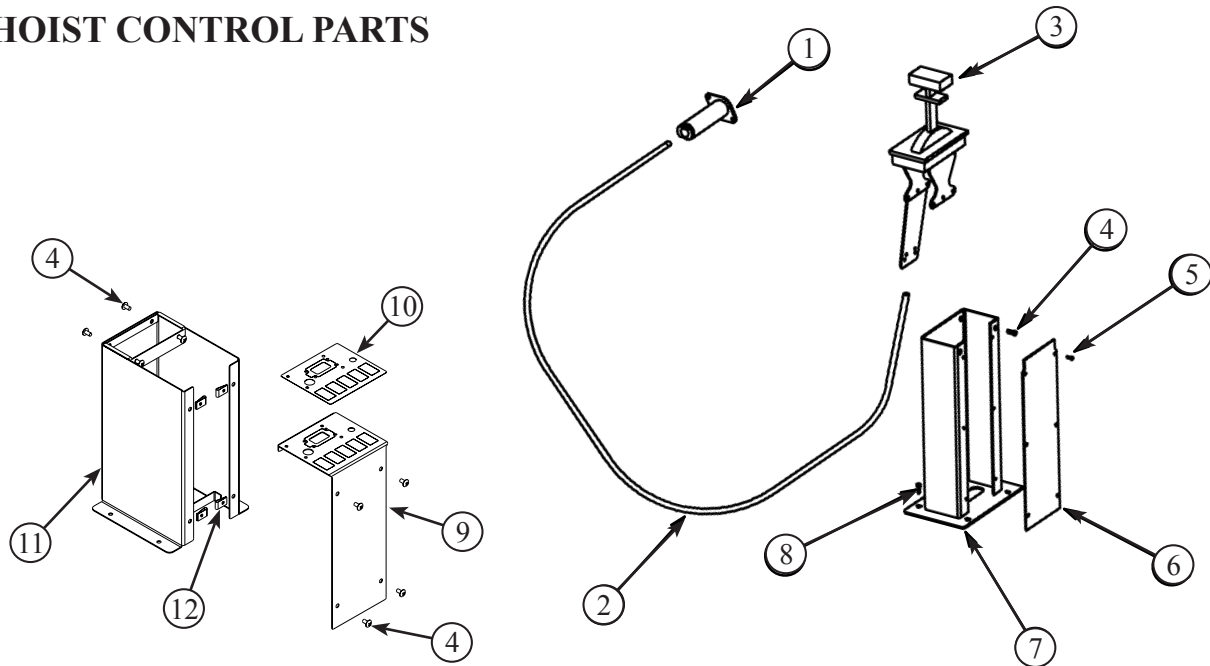

No.	Description	Model	Item No.	Qty
1.	Valve Connection Kit - 'C' Series Valve Connection Kit - Prince 5100 Valve Connection Kit - blb BM180	All T53 Series T63-T7x	1643465 1643215 1645005	1 1 1
2.	Control Cable - 84" Control Cable - 120"	All	1644733 1644734	1 1
3.	Hoist Control - Shifter Style	All	1417635	1
4.	Screw Mach 1/4-20 x 1/2 Pan Hd	All	1644840	4
5.	Screw #10 x 3/8 Self-Tapping	All	1642704	6
6.	Panel Pedestal Side	All	1630110	1
7.	Assy Shifter Pedestal	All	1621659	1
8.	Screw 5/16 x 3/4 Self-Tapping	All	1642708	4
9.	Panel, Control Tower Side	All	1638357	1
10.	Decal	All	1644843	1
11.	Assy Control Tower	All	1419604	1
12.	Nut, U-Type 1/4-20	All	1644841	4
Available Switches for Control Tower #11/#9				
	Switch - Axle (On-Off)		1644870	
	Switch - Tarp (Mom On-Off-Mom On)		1644871	
	Switch - On-Off		1644873	
	Switch - Mom On-Off		1644874	

**CRYSTEEL MANUFACTURING'S
5 YEAR CUSTOMER SATISFACTION PLEDGE
& WARRANTY**

Crysteel offers the most comprehensive warranty in the truck equipment industry. Crysteel warrants each product against defects in material and workmanship for 60 months from the in-service date.

For the full Customer Satisfaction Pledge and Warranty information, please visit our website.

<http://www.crysteel.com>

! CAUTION !

- **BODY MUST BE BRACED BEFORE SERVICING HOIST OR WORKING IN AREA WITH BODY IN RAISED POSITION**
- **LUBRICATE HOIST GREASE FITTINGS OFTEN – AT LEAST EACH TIME TRUCK IS SERVICED**
- **TRUCK MUST BE LEVEL FOR DUMPING**
- **DO NOT OVERLOAD**

CRYSTEEL MFG, INC.

CRYSTEEL MANUFACTURING, INC.
