



Website: www.TBEI.com
E-mail: sales@TBEI.com

CRYSTEEL'S STINGRAY HOIST



***THIS MANUAL MUST BE INCLUDED WITH THE VEHICLE
AFTER COMPLETING THE INSTALLATION.***

Web Site
www.crysteel.com

E-Mail
crysteel@tbei.com

Phone (507) 726-2728
Toll Free (800) 533-0494

DATE PURCHASED _____

HOIST SERIAL NUMBER _____

CYLINDER SERIAL NUMBER _____

DEALER _____

ADDRESS _____

PHONE _____

FOREWORD

The Stingray twin cylinder underbody hoist is designed for use on single and tandem axle trucks with 12 to 28 foot bodies. The Stingray line provides hoists ranging from Model 1900 in NTEA class F to the Model 7700 in NTEA class L.

This manual contains the information needed for the proper installation and operation of these hoists.

These instructions are for standard installations using a self contained reservoir/valve unit. Study this manual carefully before attempting to install or operate this product. Other hydraulic packages will come with supplemental instruction sheets when needed. With the proper installation, use and regular maintenance, Crysteel's Stingray hoist will give many years of trouble free service.

When ordering parts, be sure to give serial number of hoist, pump, and cylinder. The serial number of the pump is found on the plate on the pump. The serial number of the cylinder is stamped on the barrel of the cylinder near the base. For future reference, copy these numbers NOW in the space provided above. Order parts by number and description as given in the parts listing in this manual.

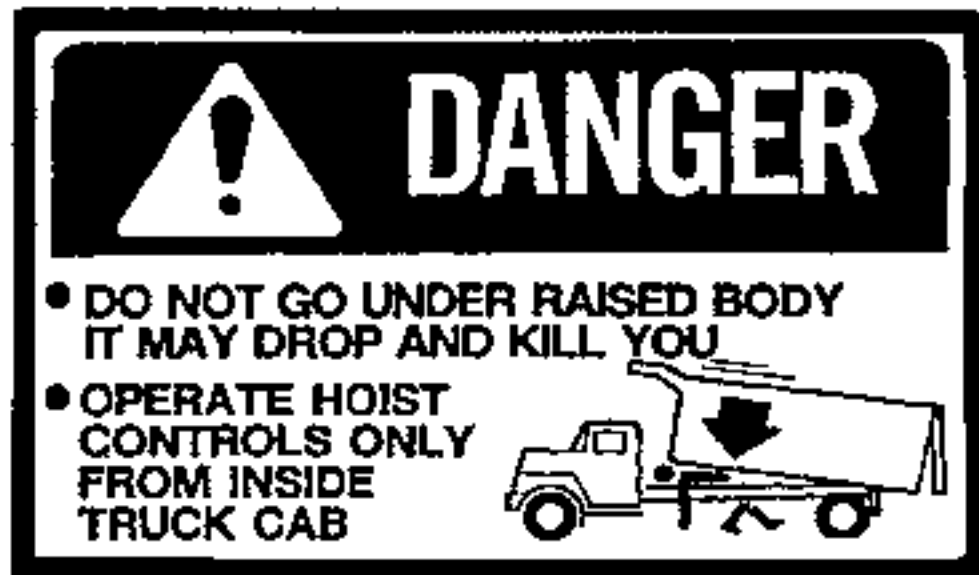

OPERATION AND USE

1. Engage PTO from cab and adjust engine speed to fast idle.
2. ALWAYS operate the hoist from inside the cab of the truck.
3. If the hydraulic hose connections are correct, the hoist should raise when the hoist control lever is pulled back, hold when the lever is in the center detent, and lower when the lever is pushed forward.
4. To raise the hoist, pull the control lever back. To hold the body in a raised position, place the control lever in its center detent position. To lower the hoist, push the control lever forward.
5. ALWAYS return the hoist control lever to its center detent position after each use.
6. When the hoist cylinder reaches the end of the stroke, oil will flow through the automatic bypass valve built into the piston inside the cylinder and return to the reservoir.
7. It is advisable to run the PTO to "power down" or lower the hoist because this will act as an hydraulic lock to hold the hoist in the lowered position. It is not necessary to do this, however, because the reservoir has sufficient capacity whether or not the hoist is powered down. You will benefit from the advantages of the double acting hoist only if you power down.
8. To make use of the hydraulic lock feature, place the hoist control lever in the center hold position after the hoist is powered down. This places the pressure on the valve, where it belongs, not on the pump.
9. DO NOT LEAVE THE PTO IN GEAR WHILE TRANSPORTING. THIS CAN CAUSE SEVERE DAMAGE TO THE PTO OR HYDRAULIC PUMP.
10. The hydraulic system should be drained, flushed and refilled with proper hydraulic fluid at regular intervals. CAUTION: NEVER use hydraulic BRAKE FLUID in the hydraulic system.
11. After adding or replacing the hydraulic fluid, cycle the hoist several times to remove air from the cylinders and hydraulic hoses.

SOME DO'S AND DON'TS FOR SAFE AND LONG SERVICE

1. Use the proper hydraulic fluid. KEEP IT CLEAN. Remember to change it regularly.
2. Lubricate all grease fittings every 100 cycles or every two months. Infrequent or insufficient lubrication will cause hoist failure and possibly injury or death.
3. ALWAYS carefully block up the body, using the body prop, before working under it.
4. Do not "race" the engine when unloading.
5. Do not load the hoist beyond its capacity.
6. DO NOT tamper with the hydraulic relief valve. This will void the warranty. It can cause severe damage to the hoist and cylinder.
7. Never leave the PTO in gear while transporting. It could ruin the hydraulic pump, the PTO or the transmission.
8. Check all bolts and fittings regularly. Keep them tight. See table on page 5 for torque values.
9. Always operate hoist on a firm and level surface.
10. Always make sure area around truck is clear and safe for hoist operation and dumping.

TABLE OF CONTENTS



FOREWORD	2
SOME DO'S AND DON'TS FOR SAFE AND LONG SERVICE OPERATION AND USE	3
INSTALLATION INSTRUCTIONS	6
COMPLETE CYLINDER INSTALLATION	6
MOUNT REAR HINGE	6
LOCATE HOIST ON TRUCK FRAME	7
MOUNT HOIST TO TRUCK FRAME	9
MOUNT GEAR PUMP	9
MOUNT RESERVOIR/VALVE ASSEMBLY	9
INSTALL REMOTE VALVE CONTROL	10
INSTALL HOSES - 1900	11
INSTALL HOSES - 4400 SINGLE-ACTING	11
INSTALL HOSES - 5500, 6600 & 7700 SINGLE-ACTING	12
INSTALL HOSES - 4400 DOUBLE-ACTING	12
INSTALL HOSES - 5500, 6600 & 7700 DOUBLE-ACTING	13
ADD HYDRAULIC OIL	14
MOUNT BODY	14
INSTALL BODY GUIDES	15
INSTALL BODY PROP	15
GREASE HOIST	16
BLEED CYLINDERS - SINGLE ACTING	17
INSTALL DECALS	17
PARTS LISTS	19

INSTALLATION INSTRUCTIONS

GENERAL INFORMATION

It is a good idea to look through these installation instructions before beginning to mount the hoist and hydraulic system.

When welding, protect the truck's electrical, air and brake systems by disconnecting, removing or covering. Tighten all nuts and bolts to a consistent level. Use the following table for torque values.

Size	Grade 2 Torque	Grade 5 Torque	Grade 8 Torque
			
1/4-20	3-4 lb-ft	6-7 lb-ft	10-11 lb-ft
1/4-28	4-5 lb-ft	8-9 lb-ft	11-12 lb-ft
5/16-18	8-9 lb-ft	14-15 lb-ft	21-22 lb-ft
5/16-24	9-10 lb-ft	15-16 lb-ft	21-22 lb-ft
3/8-16	17-18 lb-ft	24-26 lb-ft	37-40 lb-ft
3/8-24	19-20 lb-ft	28-30 lb-ft	40-43 lb-ft
1/2-13	38-42 lb-ft	60-65 lb-ft	90-100 lb-ft
1/2-20	43-47 lb-ft	70-75 lb-ft	95-105 lb-ft
5/8-11	75-80 lb-ft	122-130 lb-ft	180-190 lb-ft
5/8-18	85-90 lb-ft	145-150 lb-ft	200-210 lb-ft
3/4-10	132-140 lb-ft	220-230 lb-ft	315-330 lb-ft
3/4-16	152-160 lb-ft	250-260 lb-ft	355-370 lb-ft

The following abbreviations are used in describing hydraulic fittings.

ORBM	O-Ring Boss - Male Thread
NPTM	Pipe - Male Thread
NPTF	Pipe - Female Thread
JICM	JIC 37° - Male Thread
JICF	JIC 37° - Female Thread

INSTALLATION INSTRUCTIONS

COMPLETE CYLINDER INSTALLATION

Place the hoist upside down on the floor. The cylinders have been installed in the cylinder mounting sleeves. They need to be bolted to the crossheads.

On **DOUBLE-ACTING CYLINDERS** the head ports should be toward the center of the hoist for hoist models 4400 through 7700. Lift the base end of the cylinders to align the cylinders with the crossheads. (The hoist may need to be opened slightly to do this.) Bolt the cylinders to the crossheads using 3/8 x 1 1/2 cap screws, lock washers and hex nuts. Check the cylinder mounting screws; they should be tight.

On **SINGLE-ACTING CYLINDERS** bolt the cylinders to the crosshead using 3/8 x 1 1/2 cap screws, and hex locknuts. (The hoist may need to

be opened slightly to do this.) Check the cylinder mounting screws, they should be tight.

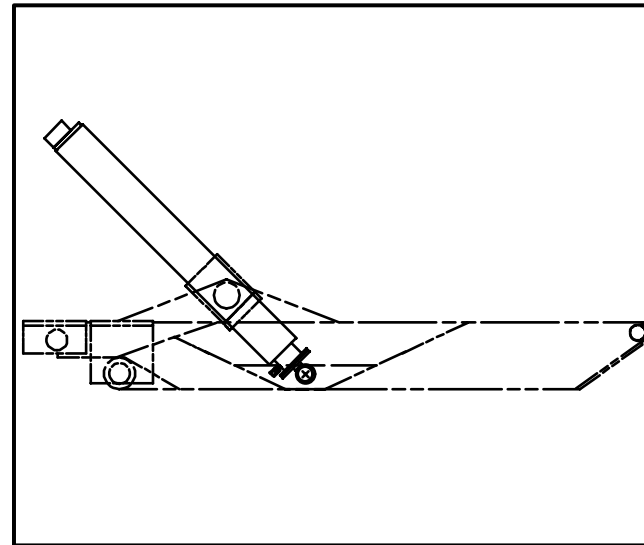

MOUNT REAR HINGE

The rear hinge must be located as close as possible behind the rear spring hanger. This will be 32 to 36 inches behind the center of the rear axle on single axle trucks and 42 to 50 inches behind the center of the tandem on tandem axle trucks. Mark the rear of the truck frame for notching as shown. Notch the truck frame as marked. Make sure the rear hinge is square with the truck frame and at the correct height. The top surface of the rear hinge bracket should be flush with the top of the angle mounting brackets of the hoist frame. Securely weld the rear hinge to the truck frame. Cap the end of the truck frame with 1/4" thick plate (not supplied) and weld all around to the truck frame and rear hinge angle.

Place the gussets in the corners formed by the truck frame rail and the rear hinge frame angle. Raise the front end of the gusset so it touches the top flange of the truck frame rail. Be sure that the gusset does not interfere with the rear hinge opera-

tion. Securely weld the gussets to the rear hinge, the truck frame rail and the top flange of the truck frame rail.

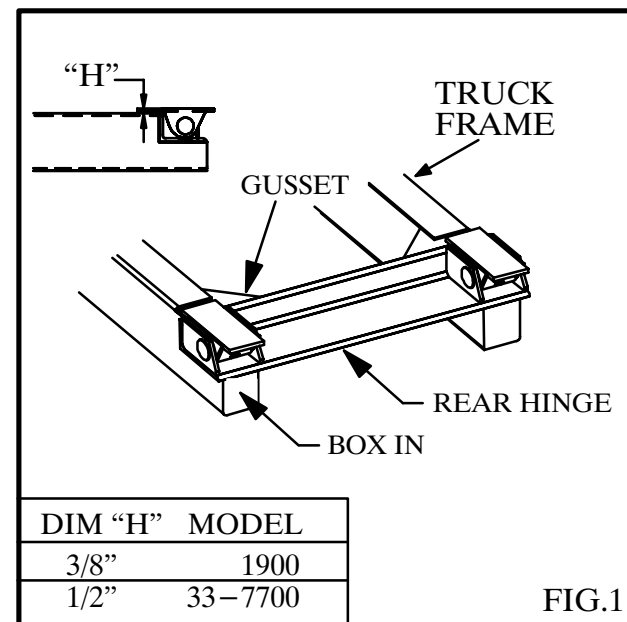

FIG.1

LOCATE HOIST ON TRUCK FRAME

Find the "D" dimension in TABLE 1, on page 6, for the hoist model and desired dump angle. Using this dimension, measure forward from the center of the rear hinge and mark the truck frame. Place the hoist on the truck frame. (See Fig. 2) Center the front cross tube of the hoist over the mark on the truck frame. Be sure to allow enough room for the cylinders to swing as the body is raised. Make sure the hoist is centered on and square with the truck frame. The angle mounting brackets must rest flat on the truck frame. If rivets are encountered in the truck frame, and the hoist cannot be moved to clear them, countersink the rivet heads into the brackets. The rear end of the main hoist frame is designed to rest on a crossmember in the truck frame. If no crossmember exists to support the hoist frame, add one.

Note: In some cases the hoist may fit the truck frame better if it is mounted reversed or "backwards" as shown in Figure 3. When mounting the hoist "backwards" be sure to measure to the front crosstube of the hoist as shown in Figure 3 and to allow enough room for the cylinders to swing as the body is raised.

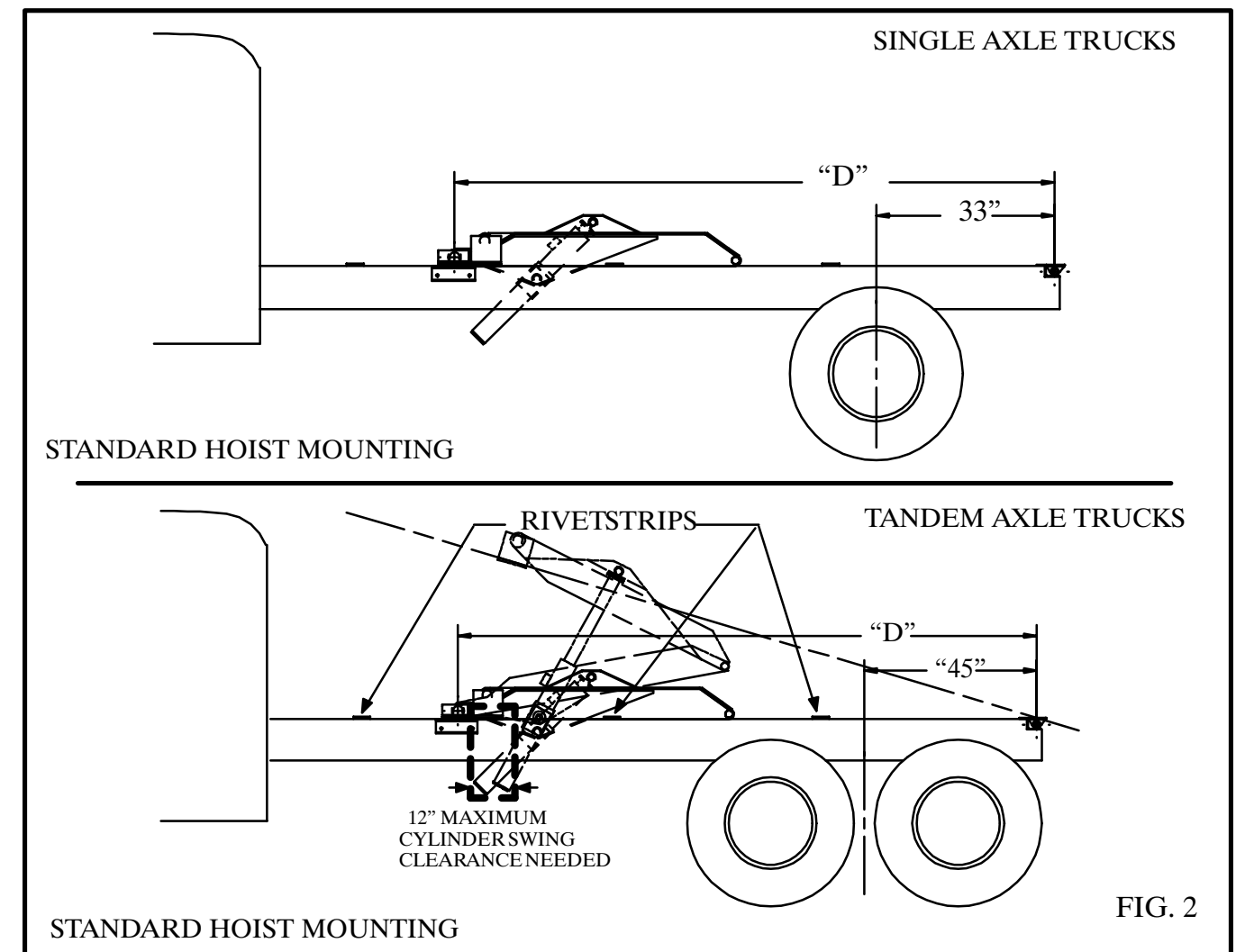

FIG. 2

NOTE: NO CROSSBRACING allowed within cylinder swing clearance area. Crossbracing will lead to interference with the working operation of the hoist. (Fig. 2 and 3 on the Tandem Axle Trucks.)

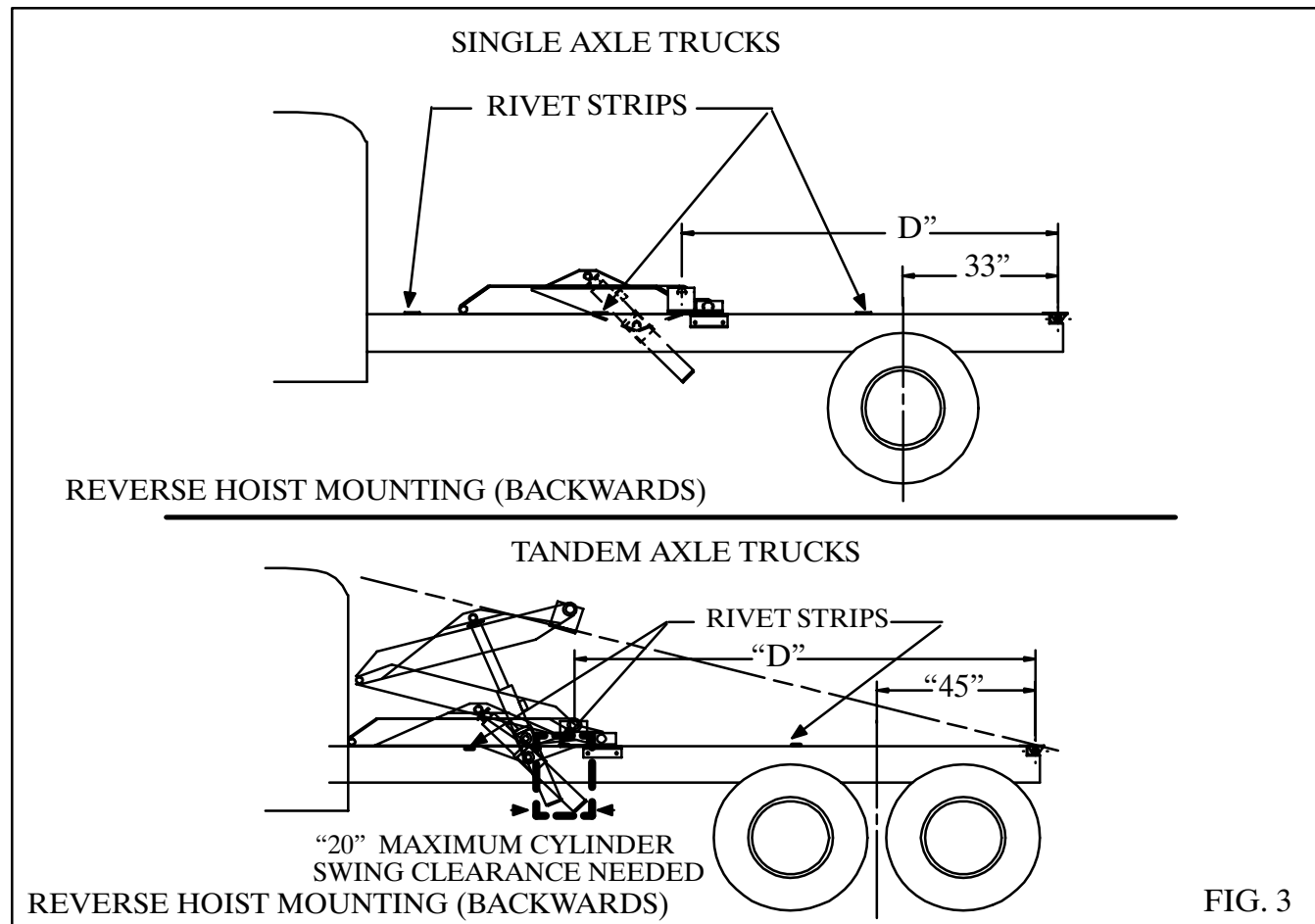

FIG. 3

TABLE 1

MODEL	DUMP ANGLE			
	40°	45°	50°	55°
1900	113"	97"	88"	81"
4400	136"	123"	111"	102"
5500	171"	153"	140"	128"
6600	191"	171"	156"	143"
7700	208"	186"	169"	155"

MOUNT HOIST TO TRUCK FRAME

Center the mounting angles under the angle mounting brackets on the hoist. Clamp them in place and mark the truck frame for drilling, using the mounting angles as guides. (See Fig. 4)

CAUTION: WHEN DRILLING THE TRUCK FRAME BE CAREFUL OF BRAKELINES, WIRING, ETC, INSIDE THE TRUCK FRAME.

Drill 21/32 inch holes in the truck frame and bolt the mounting angles in place using 5/8 x 1 3/4 cap screws, lock washers and hex nuts. Securely weld the angle mounting brackets to the mounting angles.

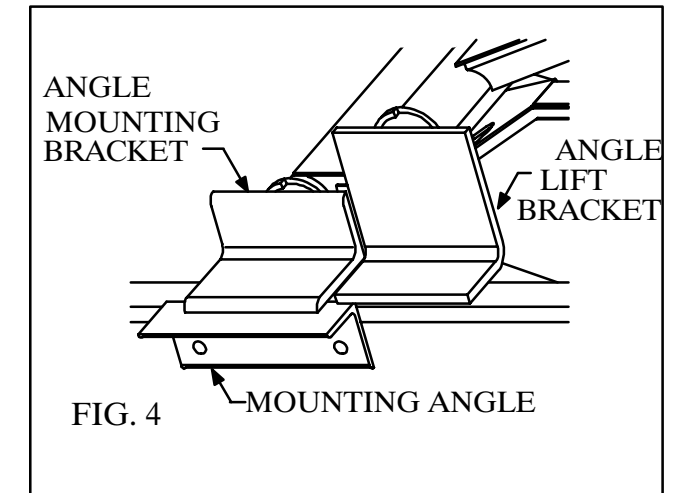

FIG. 4

MOUNT GEAR PUMP

The gear pump has an SAE 'B' mounting configuration, a 13-tooth splined shaft and a four-bolt mounting flange, and is assembled for rotation in either direction. NOTE: This pump will mount directly to Chelsea's output type 'XK' or Muncie's output type 'D'. Crysteel Manufacturing recommends a PTO ratio of 100-120%. This assures a minimum pump operating speed of 600 RPM. Bolt the gear pump to the PTO output flange using 1/2 x 1 1/4" cap screws and lock washers.

MOUNT RESERVOIR/VALVE ASSEMBLY

The reservoir/valve assembly should be mounted on the same side of the truck as the pump with the exposed end of the valve spool toward the front. Bolt the mounting angles to the reservoir/valve assembly using 3/8 x 1 cap screws, flat washers, lock washers and hex nuts. Place the valve/reservoir assembly inside the truck frame and raise it as high as possible. See Fig. 5. (There is no drive line to align and the reservoir should be higher than the pump for reliable performance.) Make sure there is enough clearance for the truck drive line and hot exhaust pipes. **THE ENGINE EXHAUST MUST NEVER BLOW DIRECTLY ONTO THE RESERVOIR/VALVE ASSEMBLY.** Clamp the mounting angles to the truck frame and mark the truck frame for drilling using the pump mounting angles as guides.

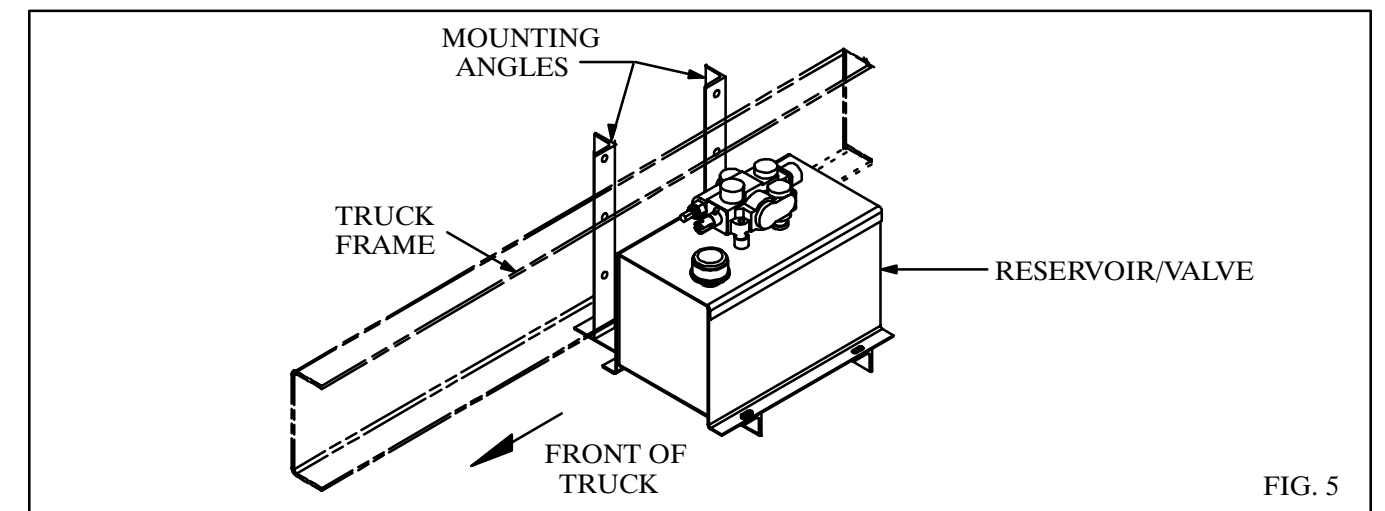

FIG. 5

CAUTION: WHEN DRILLING THE TRUCK FRAME BE CAREFUL OF BRAKELINES, WIRING, ETC. INSIDE THE TRUCK FRAME.

Drill 17/32" holes in the truck frame and bolt the reservoir/valve assembly in place using 1/2 x 1 3/4" cap screws, lock washers and hex nuts.

INSTALL REMOTE VALVE CONTROL

Temporarily assemble the valve control head to the pedestal using 5/16 x 2 1/4" machine screws and hex nuts. Place this assembly on the floor of the cab. Make sure there is enough room to operate the valve control and the gear shift lever and to adjust the seat. Check below the floor for obstructions and cable routing. Relocate the valve control if necessary. Mark the floor using the pedestal as a template and drill 1/4" holes for the mounting screws and a 3/4" hole for the control cable. Assemble the control cable to the valve control head and assemble the valve control head and cover to the pedestal using 5/16 x 2 1/4" machine screws, lock washers and hex nuts. Insert the control cable through the hole in the floor and mount the pedestal to the floor using 5/16 x 3/4" self-tapping screws. Make sure the valve control lever is in its center detent position. Keep the control cable away from hot exhaust pipes and rotating drive shafts. The control cable should not have any sharp bends or kinks in it (these will make the control harder to operate).

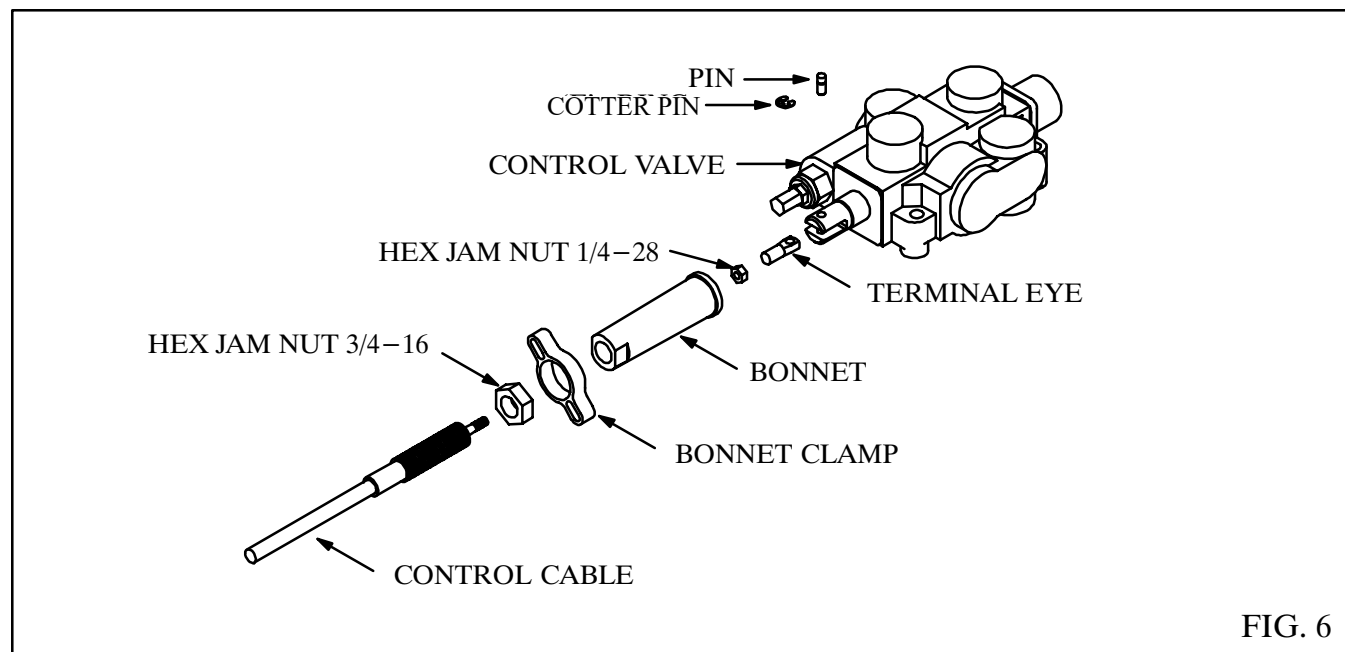

FIG. 6

Install the 3/4" hex jam nut onto the valve end of the control cable and turn past the threads. Insert the end of the cable through the bonnet clamp. Install the bonnet onto the control cable and turn it past the threads also. Install the 1/4" hex jam nut and terminal eye on the core rod of the cable. Lock the terminal eye to the core rod using the hex jam nut. Place the terminal eye in the slot of the valve spool; insert the short pin through the valve spool and terminal eye and secure it in place with the cotter pin.

Thread the bonnet onto the end of the cable so it firmly touches the end valve. (Do not over or under tighten the bonnet as either would move the valve spool out of its neutral position.) Remove two cap screws from opposite corners of the seal retainer plate. Slide the bonnet clamp onto the bonnet and secure it to the valve using the 1/4 x 1 1/4" cap screws, lock washers and flat washers. Lock the bonnet to the cable using the 3/4" hex jam nut. See Fig. 6.

INSTALL HOSES - 1900

Study Fig. 7 very carefully before connecting the hoses. Install a 3/4" 90° street elbow and a 3/4" hose barb in the suction port on the bottom of the reservoir. Install a 1 1/16 ORB x 3/4" hose barb in the suction port on the pump and install the suction hose. Secure the suction hose in place using hose clamps. Install a 1 1/16 ORB x 7/8 ORB adapter in the pressure port of the pump and install a 90° swivel adapter in the 'IN' port on the control valve. Install the 72" long 1/2" hose from the pump to the valve.

Install 90° swivel adapters in the work ports of the control valve and the ports on the base end of the cylinders; install straight swivel adapters in the ports on the rod end of the cylinders. Connect 18" long 3/8" hoses from the rod end ports of the cylinders to a swivel nut tee; connect a 60" long 3/8" hose from this tee to the 'A' port on the control valve. Connect 18" long 3/8" hoses from the base end ports of the cylinders to a swivel nut tee; connect a 60" long 3/8" hose from this tee to the 'B' port on the control valve. This will raise the hoist when the control lever is pulled back and lower it when pushed forward. Secure the 18" long hoses to the cylinder mount using the tie straps provided.

NOTE: The 'A' port is the 'power-down' port and has a pressure of only 500-1000 PSI at engine idle; the 'B' port has full system pressure.

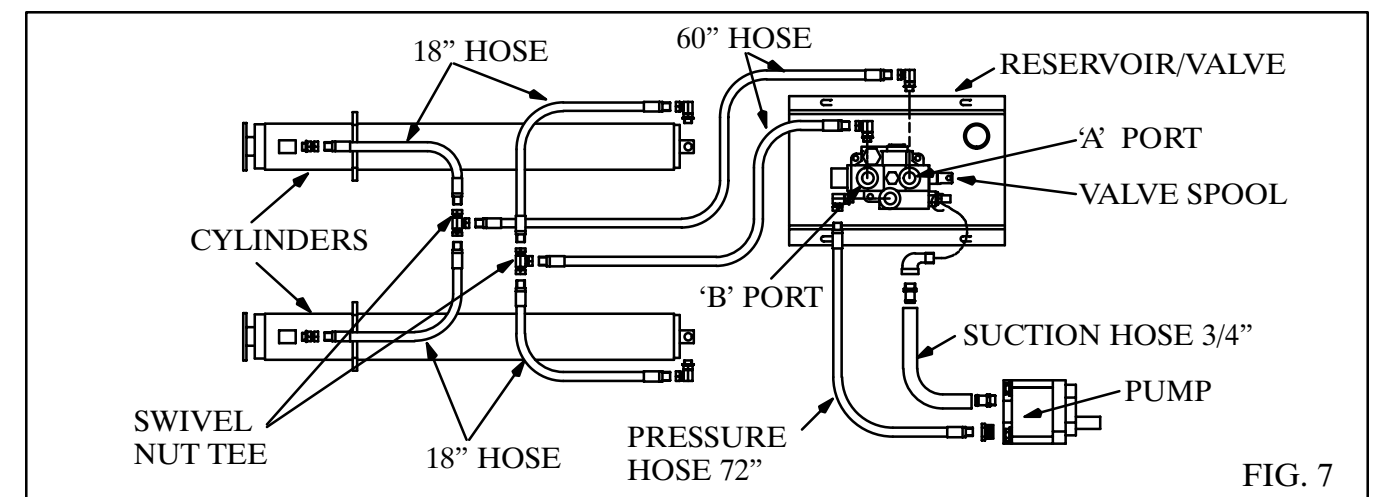
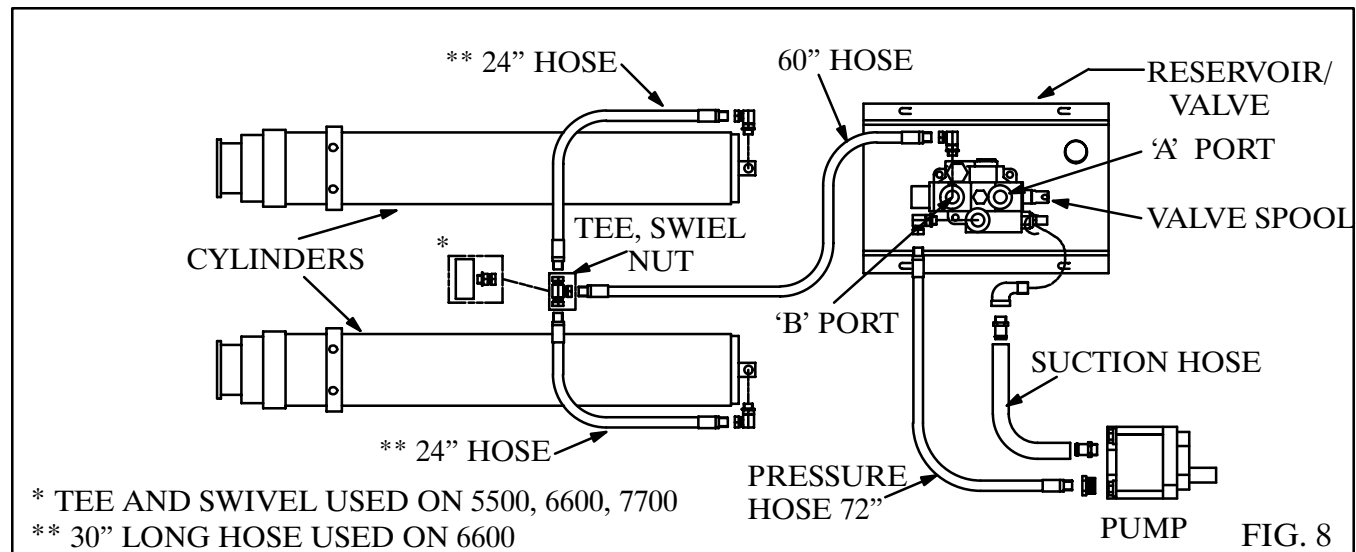

FIG. 7

INSTALL HOSES - 4400 SINGLE-ACTING

Study Fig. 8 very carefully before connecting the hoses. Install a 1 1/4" 90° street elbow and a 1 1/4" hose barb in the suction port on the bottom of the reservoir. Install a 1 5/16 ORB x 1 1/4" hose barb in the suction port on the pump and install the suction hose. Secure the suction hose in place using hose clamps. Install a 1 5/16 ORB x 1/2 NPT adapter in the pressure port of the pump and install a 90° swivel adapter in the 'IN' port on the control valve. Install the 72" long 1/2" hose from the pump to the valve.

Install 90° swivel adapters in the 'B' work port of the control valve and the ports on the base end of the cylinders. Connect a 60" long 1/2" hose from the control valve to the swivel nut tee; connect 24" long 1/2" hoses from the tee to the ports on the base end of the cylinder. This will raise the hoist when the control lever is pulled back and lower it when pushed forward. Secure the 24" long hoses to the cylinder mount using the tie straps provided.



INSTALL HOSES - 5500, 6600 & 7700 SINGLE-ACTING

Study Fig. 8 very carefully before connecting the hoses. Install a 1 1/2" 90° street elbow and an 1 1/2" hose barb in the suction port on the bottom of the reservoir. Install a 1 5/16 ORB x 1 1/2" hose barb in the suction port of the pump and install the suction hose. Secure the suction hose in place using hose clamps. Install a 1 5/16 ORB x 3/4" NPT adapter in the pressure port of the pump and install a 90° swivel adapter in the "IN" port of the control valve. Install the 72" long 3/4" hose from the pump to the valve.

Install 90° swivel adapters in the 'B' work port of the control valve and the ports on the base end of the cylinders. Install a 7/8 ORB x 3/4" NPT swivel in the middle port of the 7/8 ORB tee.

Connect a 60" long 3/4" hose from the 'B' port of the control valve to the middle port of the tee; connect 24" long 1/2 NPT-7/8 ORB hoses (30" long hoses for the 6600) from the tee to the ports on the base end of the cylinders. This will raise the hoist when the control lever is pulled back and lower it when pushed forward. Secure the 24" (30") long hoses to the cylinder mount using the tie straps provided.

INSTALL HOSES - 4400 DOUBLE-ACTING

Study Fig. 9 very carefully before connecting the hoses. Install a 1 1/4" 90° street elbow and a 1 1/4" hose barb in the suction port on the bottom of the reservoir. Install a 1 5/16 ORB x 1 1/4" hose barb in the suction port on the pump and install the suction hose. Secure the suction hose in place using hose clamps. Install a 1 5/16 ORB x 1/2 NPT adapter in the pressure port of the pump and install a 90° swivel adapter in the 'IN' port of the control valve. Install the 72" long 1/2" hose from the pump to the valve.

Install 90° swivel adapters in the work ports of the control valve and the ports on the base end of the cylinders. Connect a 60" long 1/2" hose from the 'B' port of the control valve to the swivel nut tee; connect 24" long 1/2" hose from the tee to the ports on the base end of the cylinder. Secure the 24" long hoses to the cylinder mount using the tie straps provided.

There is plumbing inside the hoist frame for the power down function of the hoist. Install a 3/8 NPT x 1/2 NPT swivel adapter in the pipe elbow near the front of the hoist frame. Connect a 42" long 1/2" hose from the 'A' port on the control valve to the swivel adapter. Connect 27" long 1/4" hoses from the pipe fittings on the upper frame to the ports on the rod end of the cylinders. This will raise the hoist when the control

lever is pulled back and lower it when pushed forward.

NOTE: Only the smallest stage is double acting.

NOTE: The 'A' port is the 'power-down' port and has a pressure of only 500-1000 PSI at engine idle; the 'B' port has full system pressure.

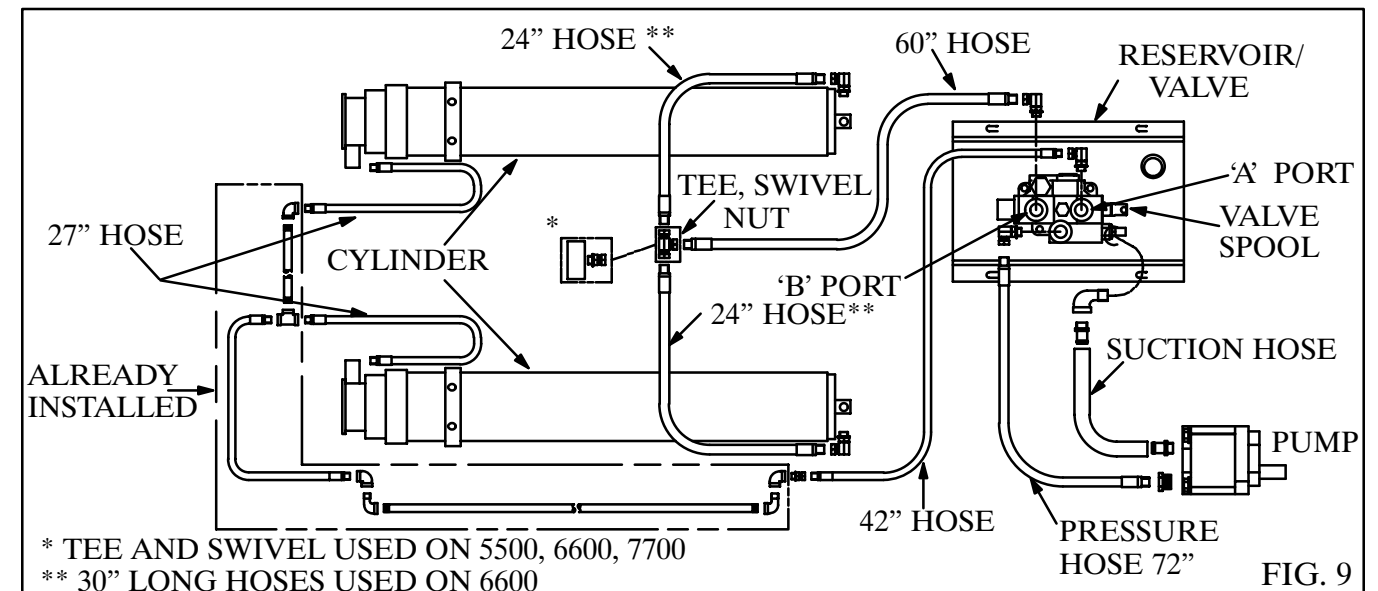

INSTALL HOSES - 5500, 6600 & 7700 DOUBLE-ACTING

Study Fig. 9 very carefully before connecting the hoses. Install a 1 1/2" 90° street elbow and an 1 1/2" hose barb in the suction port on the bottom of the reservoir. Install a 1 5/16 ORB x 1 1/2" hose barb in the suction port of the pump and install the suction hose. Secure the suction hose in place using hose clamps. Install a 1 5/16 ORB x 3/4 NPT adapter in the pressure port of the pump and install a 90° swivel adapter in the 'IN' port of the control valve. Install the 72" long 3/4" hose from the pump to the valve.

Install 90° swivel adapters in the work ports of the control valve and the ports on the base end of the cylinders. Install a 7/8 ORB x 3/4 NPT swivel in the middle port of the 7/8 ORB tee. Connect a 60" long 3/4" hose from the 'B' port of the control valve to the middle port of the tee; connect 24" long 1/2 " hoses (30" long hoses for the 6600) from the tee to the ports on the base end of the cylinders. Secure the 24" (30") long hoses to the cylinder mount using the tie straps provided.

There is plumbing inside the hoist frame for the power down function of the hoist. Install a 3/8 NPT x 1/2 NPT swivel adapter in the pipe elbow near the front of the hoist frame. Connect a 42" long 1/2" hose from the 'A' port on the control valve to the swivel adapter. Connect 27" long 1/4" hoses from the pipe fittings on the upper frame to the ports on the rod end of the cylinders. This will raise the hoist when the control lever is pulled back and lower it when pushed forward.

NOTE: Only the smallest stage is double acting.

NOTE: The 'A' port is the 'power-down' port and has a pressure of only 500-1000 PSI at engine idle; the 'B' port has full system pressure.

ADDHYDRAULICOIL

Refer to TABLE 2 below for the amount of hydraulic oil required to operate the hoist. Use a quality hydraulic fluid of 150 SSU @ 100_F. which contains corrosion and oxidation inhibitors and a foam depressant. This is approximately the equivalent of SAE 10W or lighter weight oil, or use Type A automatic transmission fluid for improved performance in cold weather.

TABLE 2

HOIST MODEL	RESERVOIR SIZE	OIL REQUIRED
1900	6 GAL.	15 QTS
4400	8 GAL.	27 QTS
5500	14 GAL.	34 QTS
6600	14 GAL.	39 QTS
7700	14 GAL.	42 QTS

MOUNT BODY

It is recommended that the body be painted before it is mounted on the truck. Place the body in position on the truck with three inches of clearance behind the cab. Use the rivet strip mounting pads between the longbeams and the truck frame. Use three on each side, spaced as seen on Fig. 2 on page 5 or Fig. 3 on page 6. Weld them to the longbeams. Align body longbeams carefully with the truck frame. Securely weld the longbeams to the rear hinge brackets.

Weld the longbeams to the angle lift brackets of the hoist. On the inside of the longbeams, insert the filler plate between the lift bracket and the longbeam. Securely weld the filler plate to the angle lift brackets and to the top flange of the longbeam channels as shown in Fig. 10. For Crysteel's grain body, place the filler plate between the angle lift bracket and the inside of the longbeam as shown in Fig. 11. Securely weld this plate to the longbeam and to the lift bracket. Be sure to do this on both sides.

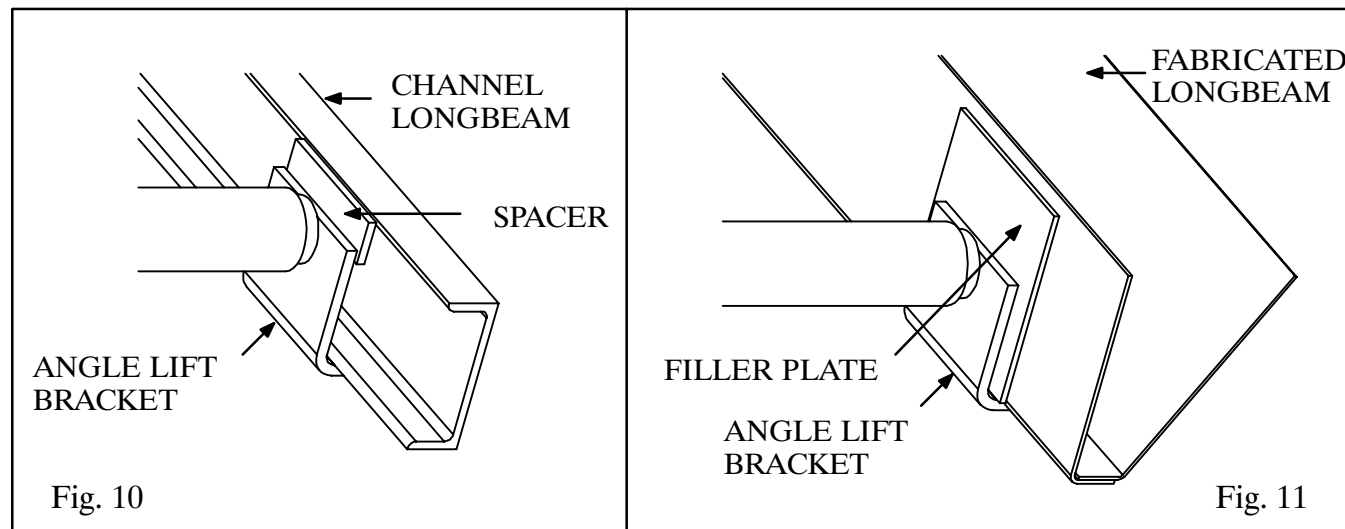

INSTALLBODYGUIDES

The four body guides supplied with your hoist are of two types. Part number 217503 has an obtuse angle that allows it to match the angle of fabricated longbeams. Position this type as shown in Fig. 12 with wide end down, pushed against the longbeam, and centered over the hoist lower mounting angle. Weld securely to the mounting angles. DO NOT use the other body guides with fabricated longbeams.

Part number 201415 body guide is used with channel type longbeams and has a right angle that allows it to be positioned as shown in Fig. 13. Position this guide 1/4" away from the longbeam, centered over the lower mounting angle. Place the 217503 body guide inside of it as shown so that the flat sides of the guides fit together. Weld number 201415 to the lower mounting angle and 217503 to the longbeam.

There should be NO SIDEPLAY when the truck body is in the lowered position.

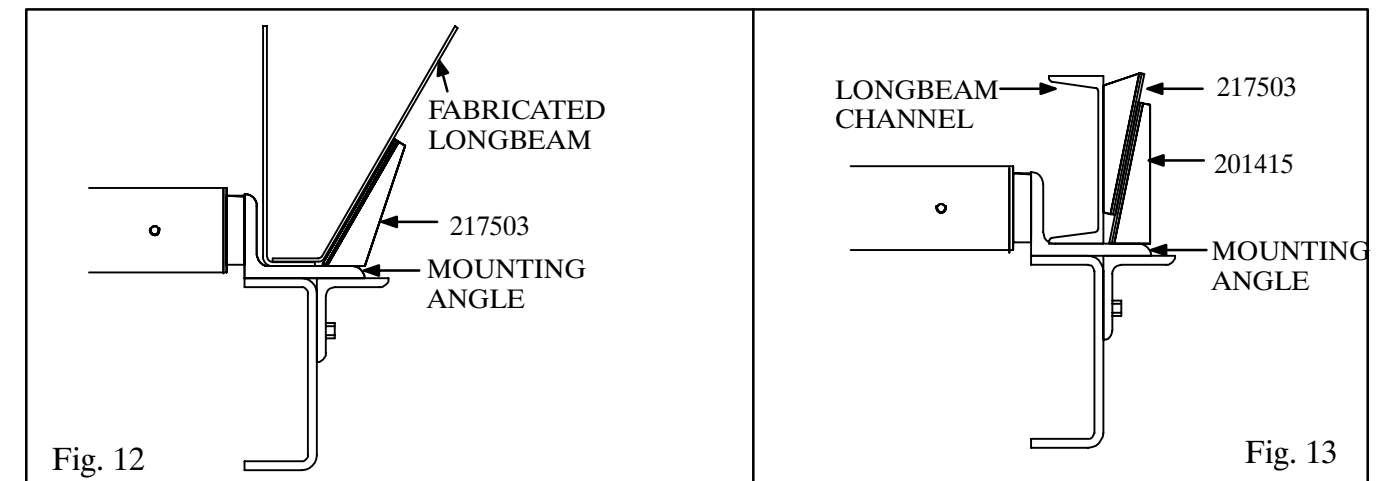

INSTALL BODY PROP

The body prop is designed and intended to support an EMPTY truck body in the raised position. Use of the body prop permits service to be performed safely beneath a raised body. One body prop is included with Stingray Hoist models 1900; two body props (one pair) are included with models 4400 through 7700. Be sure to install each prop on the correct side of the truck as explained below. (See Fig. 14)

1. Raise the body to a 30° to 35° angle and brace it securely before beginning installation.
2. Assemble the prop arm to the prop pivot mount with a 1/4 x 3 roll pin. Clamp the prop pivot mount against the outside of the truck frame just behind the rear axle. Raise the body prop arm to a free standing position. Place the body prop bracket in the prop arm saddle. Reposition if needed to locate the prop bracket on the longbeam. It may be necessary to raise or lower the body to get the best location for the prop pivot mount. Using the prop pivot mount as a guide, mark the location of holes on the truck frame and drill 17/32 inch holes. Assemble the prop pivot mount to the frame using 1/2 x 2 cap screws, lock washers and hex nuts. Raise the prop arm to a free standing position, place the body prop bracket in the saddle and securely weld the bracket to the longbeam.
3. When mounting two body props, repeat steps 1 and 2 for the other side. Use the body prop already mounted to assure that both body props hold the body at the same height. The left and right body props should pivot toward the front of the truck in the storage position.

4. To operate the body prop, raise the body to the desired height, shut off all power, raise the prop arm to a free standing position. Lower the body slowly until the body prop bracket contacts the prop arm saddle. **DO NOT POWER HOIST DOWN.**
5. To place the body prop in the storage position, raise the body to clear the body prop saddle, lower the body prop to the storage position and lower the body.

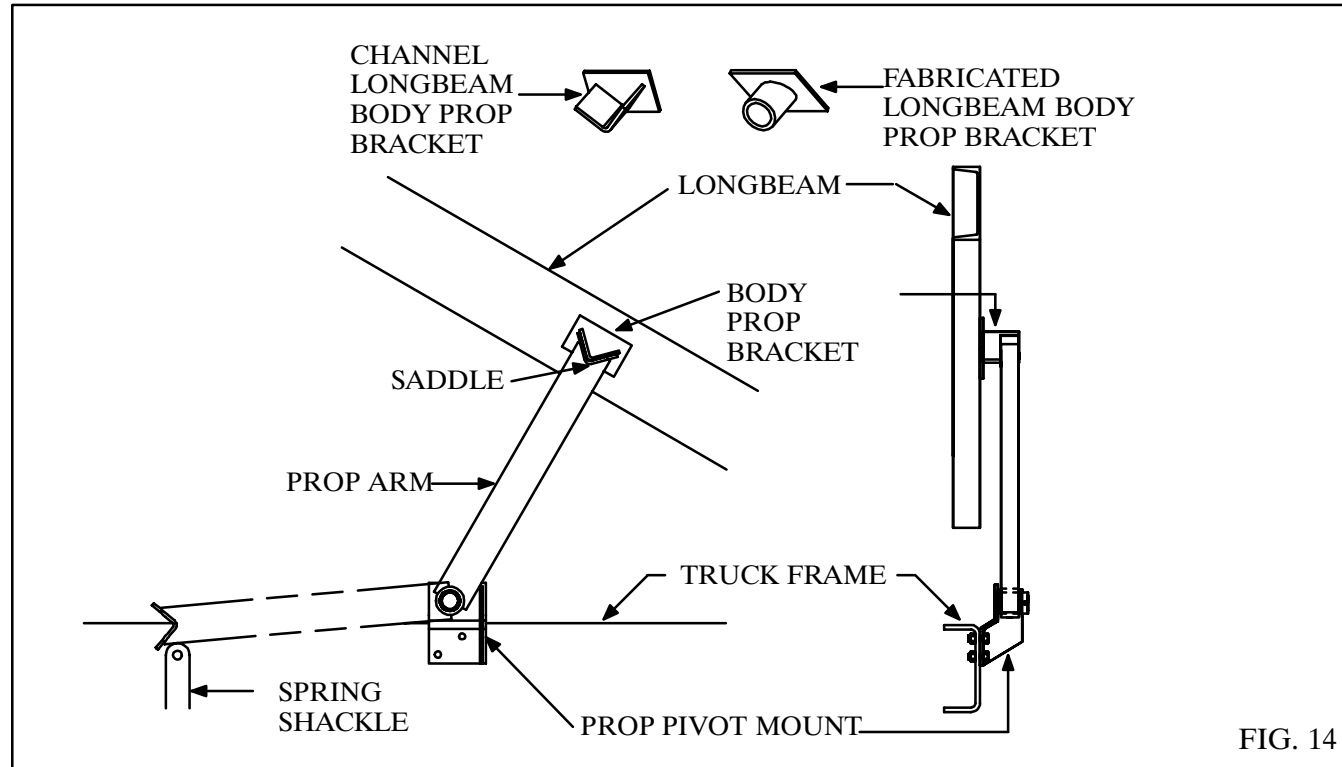

FIG. 14

GREASE HOIST

Install grease zerks and lubricate in the following locations:

- | | |
|--------------------|------------------------|
| A. Upper Crosstube | 2 fittings |
| B. Lower Crosstube | 2 fittings |
| C. Body Props | 2 fittings |
| D. Rear Hinge | 2 fittings (Installed) |

Lubricate all fittings at regular intervals, at least every 100 cycles or 2 months. There are very high forces on the bearing surfaces within the hoist frame. It pays to be generous in lubricating the hoist to ensure proper operation and long life.

PROPER LUBRICATION IS EXTREMELY IMPORTANT!

The center hinge, the cylinder crossheads and the lower cylinder mount do not need to be greased. These pivot points are equipped with self lubricating composite bearings that do not need lubrication.

ONE OF THE MOST COMMON REASONS FOR HOIST PROBLEMS IS FAILURE BY THE OPERATOR TO LUBRICATE THE HOIST.

BLEED CYLINDERS - SINGLE ACTING

The StingRay single-acting cylinders are equipped with a self-bleeding feature. When first installed, raise the body to full height and lower completely two or three times. Air is removed from the cylinder every time the hoist is cycled. No further bleeding is required.

NOTE: Double-acting cylinders do not have bleed valves because they bleed themselves in use. Cycle the hoist several times to remove any air from the cylinders

INSTALLDECALS

After the body and hoist have been installed and painted, install the decals in the following locations:

1. Decal 1642848 Mount on the body longbeam near the body prop. (one on each side)
2. Decal 1642846 Mount on the body prop arm.
3. Decal 1643067 Mount on the outside of the body longbeams near the front of the body. (one on each side).
4. Decal 1642844 Mount on the body longbeam on the drivers side.
5. Decal 1643068 Mount in the cab in a prominent location.
6. Decal 1642843 Mount in the cab in a prominent location.

See the illustrations on the following page for decal identification. (See Fig. 15.)

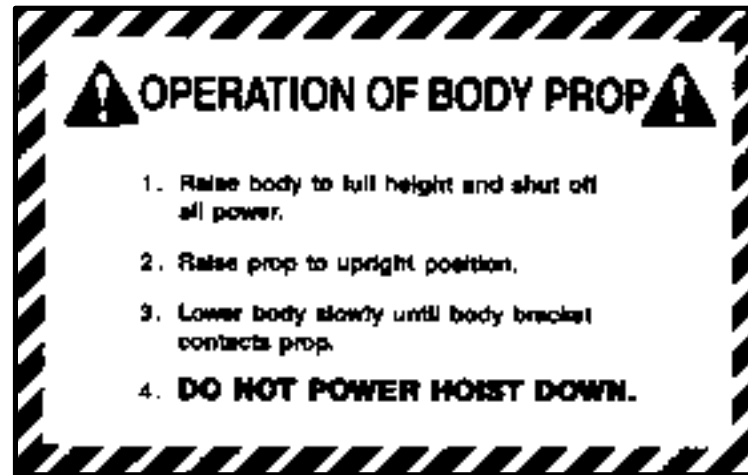

1642848 Mount on the body longbeam near the body prop

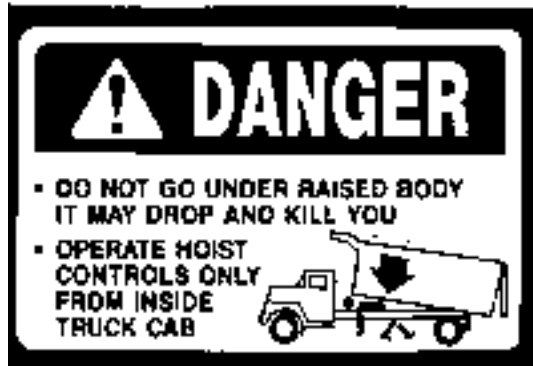

1643067 Mount on the outside of the body longbeams near the front of the body (one on each side).



1642844 Mount on the longbeam on the drivers side.



1643068 Mount in the cab in a prominent location



1642843 Mount in the cab in a prominent location



1642846 Mount on the body prop arm.

Fig. 15

STINGRAY1900HOISTPARTS

SR1900 HOIST FRAME

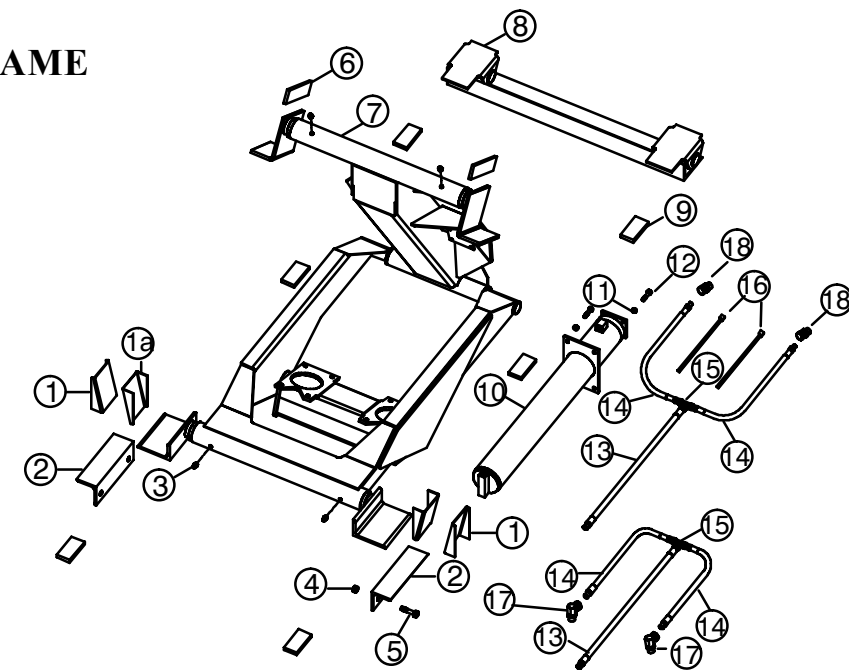

ITEM	DESCRIPTION	SR1900	QTY
1.	Body Guide	1629456	2
1a.	Body Guide	1630513	2
2.	Mounting Angle	1629458	2
3.	Grease Zerk 1/8 NPT, Straight	1645187	6
4.	Hex Lock Nut 5/8-11	1643070	4
5.	Hex Cap Screw 5/8-11 x 2	1643313	4
6.	Longbeam Filler	1629382	2
7.	Hoist Frame	1621823	1
8.	Rear Hinge	1621587	1
9.	Longbeam Spacer	1629377	6
10.	Cylinder	1621794	2
11.	Hex Lock Nut 3/8-16	1643177	8
12.	Hex Cap Screw 3/8-16 x 1 1/2	1642710	8
13.	Hose 3/8 NPT x 60	1643348	2
14.	Hose 3/8 NPT x 18	1643347	4
15.	Swivel Tee 3/8 NPSM	1643235	2
16.	Tie Strap	1643056	2
17.	Adapter 9/16 ORBM X 3/8 NPSM 90°	1643239	2
18.	Adapter 9/16 ORBM X 3/8 NPSM	1643238	1

STINGRAY1900CYLINDERPARTS

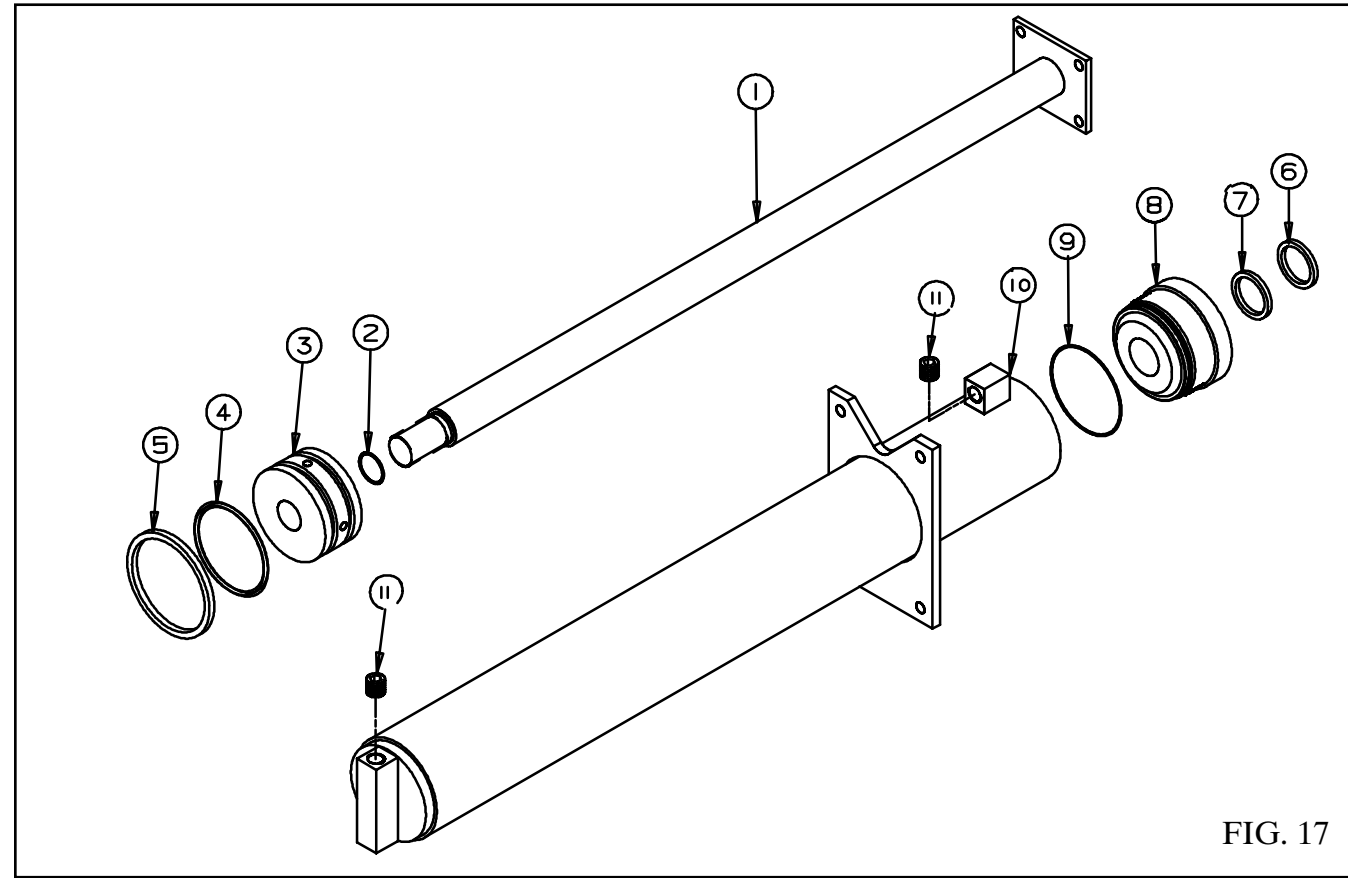
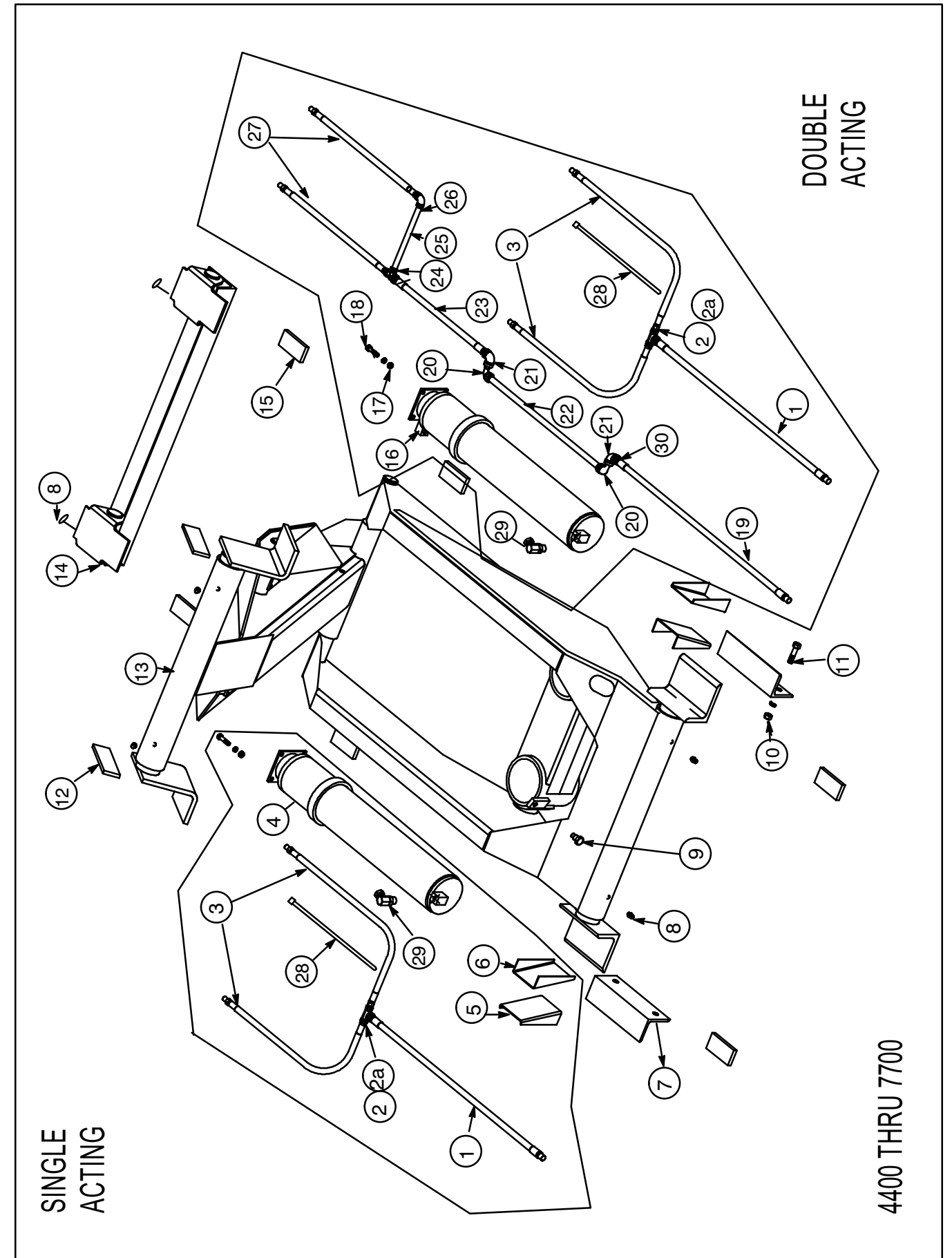

FIG. 17

ITEM	DESCRIPTION	SR1900	QTY
1.	Shaft Assy	1621812	1
2.	O-Ring *	1642940	1
3.	Piston	1630418	1
4.	O-Ring *	1643080	1
5.	Poly Seal *	1643092	1
6.	Wiper	1643081	1
7.	Poly Seal *	1642941	1
8.	Head	1630417	1
9.	O-Ring *	1642890	1
10.	Outer Tube Assy	1621796	1
11.	Plug 9/16 ORB	1642793	1
12.	Seal Kit	1621831	1



ITEM	DESCRIPTION	MODEL 4400	MODEL 5500	MODEL 6600	MODEL 7700	QTY.
1.	Hose 1/2 NPT	1643225	1643154	1643154	1643154	1
2.	Tee 1/2 NPSM Swivel	1643242				1
	Tee 7/8 ORB		1629343	1629343	1629343	1
2a.	Swivel 7/8 ORBM x 3/4 NPTF		1643192	1643192	1643192	1
3.	Hose 1/2 NPT	1643243	1642979	1643237	1642979	2
4.	Cylinder - SA	1622309	1622310	1622311	1622312	2
5.	Body Guide	1629456	1629456	1629456	1629456	2
6.	Body Guide	1630513	1630513	1630513	1630513	2
7.	Mounting Angle	1629458	1629458	1629458	1629458	2
8.	Grease Zerk	1645187	1645187	1645187	1645187	6
9.	Retaining Screw	1643079	1643079	1643079	1643079	2
10.	Hex Lock Nut 5/8-11	1643070	1643070	1643070	1643070	4
11.	Hex Cap Screw 5/8-11 x 2	1643313	1643313	1643313	1643313	4
12.	Longbeam Filler	1629379	1629379	1629379	1629379	2
13.	Hoist Frame - SA	1621713	1621693	1621723	1621732	1
	Hoist Frame - DA	1621782	1621783	1621784	1621785	1
14.	Rear Hinge	1283750	1283750	1283750	1283750	1
15.	Longbeam Spacer	1629376	1629376	1629376	1629376	6
16.	Cylinder - DA	1621768	1621769	1621770	1621771	1
17.	Hex Lock Nut 3/8-16	1643177	1643177	1643177	1643177	8
18.	Hex Cap Screw 3/8-16 x 1 1/2	1642710	1642710	1642710	1642710	8
19.	Hose 1/2 NPT x 42	1643223	1643223	1643223	1643223	1
20.	Street Elbow 3/8 Pipe	1642796	1642796	1642796	1642796	2
21.	Elbow 3/8 Pipe	1642797	1642797	1642797	1642797	2
22.	Pipe 3/8	1643050	1643072	1643073	1643074	1
23.	Hose 3/8 NPT	1642821	1642823	1642824	1642825	1
24.	Tee Reducing 3/8 x 1/4 x 1/4	1643048	1643048	1643048	1643048	1
25.	Pipe 1/4 x 9	1643049	1643049	1643049	1643049	1
26.	Elbow 1/4 Pipe	1642801	1642801	1642801	1642801	1
27.	Hose 1/4 NPT x 27	1643284	1643284	1643284	1643284	1
28.	Tie Strap	1643056	1643056	1643056	1643056	3
29.	Adapter 7/8 ORBM x 1/2 NPTF 90°	1642927	1642927	1642927	1642927	2
30.	Swivel 3/8 NPTM x 1/2 NPTF	1643232	1643232	1643232	1643232	1

STINGRAY 4400-7700 SA CYLINDER PARTS

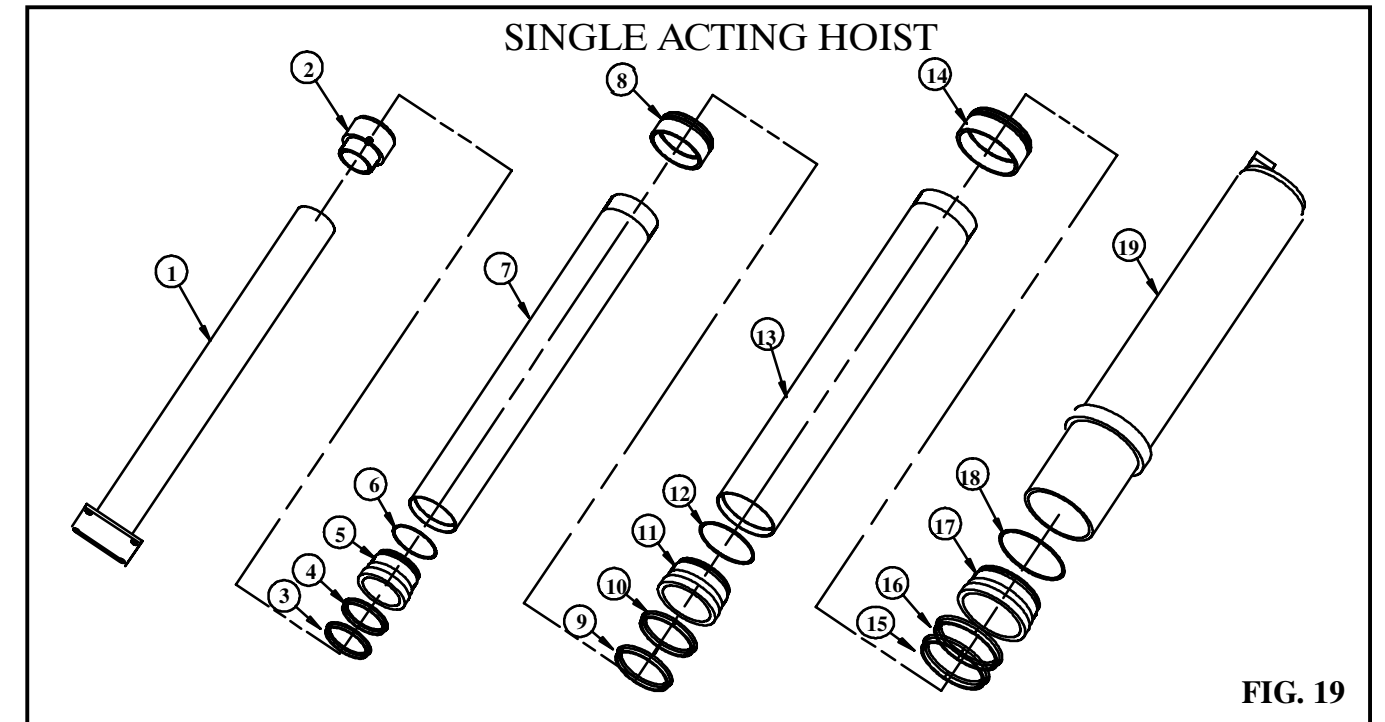

FIG. 19

ITEM	DESCRIPTION	MODEL 4400	MODEL 5500	MODEL 6600	MODEL 7700	QTY.
1.	Inner Tube Assy	1622604	1622711	1622712	1622713	1
2.	Inner Piston	1630331	1630330	1630330	1630330	1
3.	Wiper 2 3/4 ID *	---	1643380	1643380	1643380	1
4.	Seal 2 3/4 ID x 1/4 *	---	1643107	1643107	1643107	1
5.	Head 2 3/4 ID	---	1632755	1632755	1632755	1
6.	O-Ring 2 7/8 ID x .070 *	---	1642889	1642889	1642889	1
7.	Stage Tube 3 1/2 OD	---	1632492	1632493	1632494	1
8.	Piston 3 1/2" Stage	---	1629926	1629926	1629926	1
9.	Wiper 3 1/2 ID *	1643366	1643366	1643366	1643366	1
10.	Seal 3 1/2 ID x 1/4	1643108	1643108	1643108	1643108	1
11.	Head 3 1/2 ID	1632507	1632507	1632507	1632507	1
12.	O-Ring 3 1/2 ID x .070	1642890	1642890	1642890	1642890	1
13.	Stage Tube 4 1/4 OD	1632761	1632762	1632763	1632764	1
14.	Piston 4 1/4" Stage	1629927	1629927	1629927	1629927	1
15.	Wiper 4 1/4 ID *	1643367	1643367	1643367	1643367	1
16.	Seal 4 1/4 ID x 1/4 *	1643109	1643109	1643109	1643109	1
17.	Head 4 1/4 ID	1632756	1632756	1632756	1632756	1
18.	O-Ring 4 1/4 ID x .070 *	1642891	1642891	1642891	1642891	1
19.	Outer Tube Assy	1622791	1622602	1622792	1622793	1
20.	Seal Kit (Includes * items)	1621862	1621863	1621863	1621863	1

STINGRAY 4400-7700 DACYLINDER PARTS

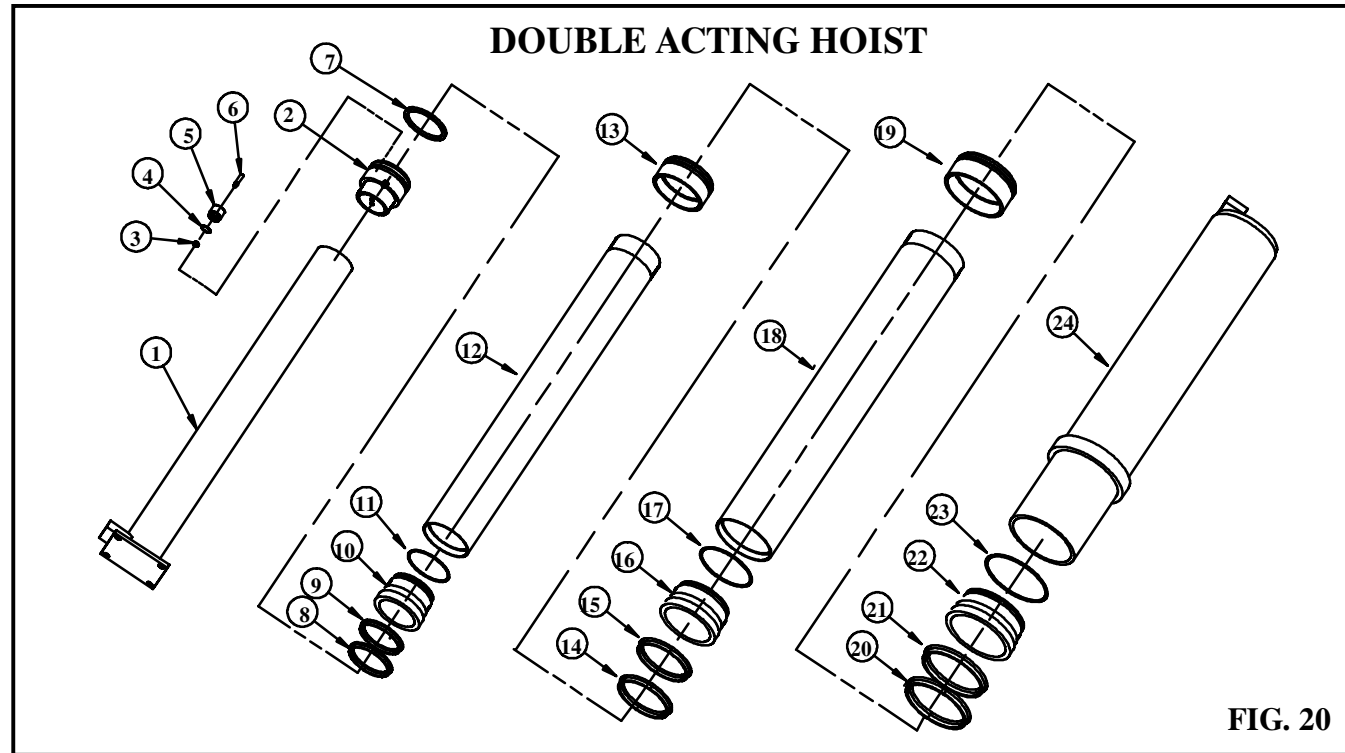

FIG. 20

ITEM	DESCRIPTION	MODEL 4400	MODEL 5500	MODEL 6600	MODEL 7700	QTY.
1.	Inner Tube Assy	1622603	1622707	1622708	1622709	1
2.	Inner Piston	1630550	1630549	1630549	1630549	1
3.	Ball 3/8 Dia	1642679	1642679	1642679	1642679	1
4.	O-Ring 7/16 ID x .070	1642907	1642907	1642907	1642907	1
5.	Body, Bypass Valve	1642893	1642893	1642893	1642893	1
6.	Pin, Bypass Valve	1642992	1642992	1642992	1642992	1
7.	Seal, PIP 3" OD *	---	1643132	1643132	1643132	1
	Seal, PIP 3 3/4" OD *	1643133	---	---	---	1
8.	Wiper 2 3/4 ID *	---	1643380	1643380	1643380	1
9.	Seal 2 3/4 ID x 1/4 *	---	1643107	1643107	1643107	1
10.	Head 2 3/4 ID	---	1632755	1632755	1632755	1
11.	O-Ring 2 7/8 ID x .070 *	---	1642889	1642889	1642889	1
12.	Stage Tube 3 1/2 OD	---	1630546	1630547	1630548	1
13.	Piston 3 1/2" Stage	---	1629926	1629926	1629926	1
14.	Wiper 3 1/2 ID *	1643366	1643366	1643366	1643366	1
15.	Seal 3 1/2 ID x 1/4	1643108	1643108	1643108	1643108	1
16.	Head 3 1/2 ID	1632507	1632507	1632507	1632507	1
17.	O-Ring 3 1/2 ID x .070	1642890	1642890	1642890	1642890	1
18.	Stage Tube 4 1/4 OD	1632773	1632762	1632763	1632764	1
19.	Piston 4 1/4" Stage	1629927	1629927	1629927	1629927	1
20.	Wiper 4 1/4 ID *	1643367	1643367	1643367	1643367	1
21.	Seal 4 1/4 ID x 1/4 *	1643109	1643109	1643109	1643109	1

ITEM	DESCRIPTION	MODEL 4400	MODEL 5500	MODEL 6600	MODEL 7700	QTY.
22.	Head 4 1/4 ID	1632756	1632756	1632756	1632756	1
23.	O-Ring 4 1/4 ID x .070 *	1642891	1642891	1642891	1642891	1
24.	Outer Tube Assy	1621838	1621839	1621840	1621841	1
25.	Seal Kit (Includes * items)	1621866	1621867	1621867	1621867	1

STINGRAY HYDRAULICS

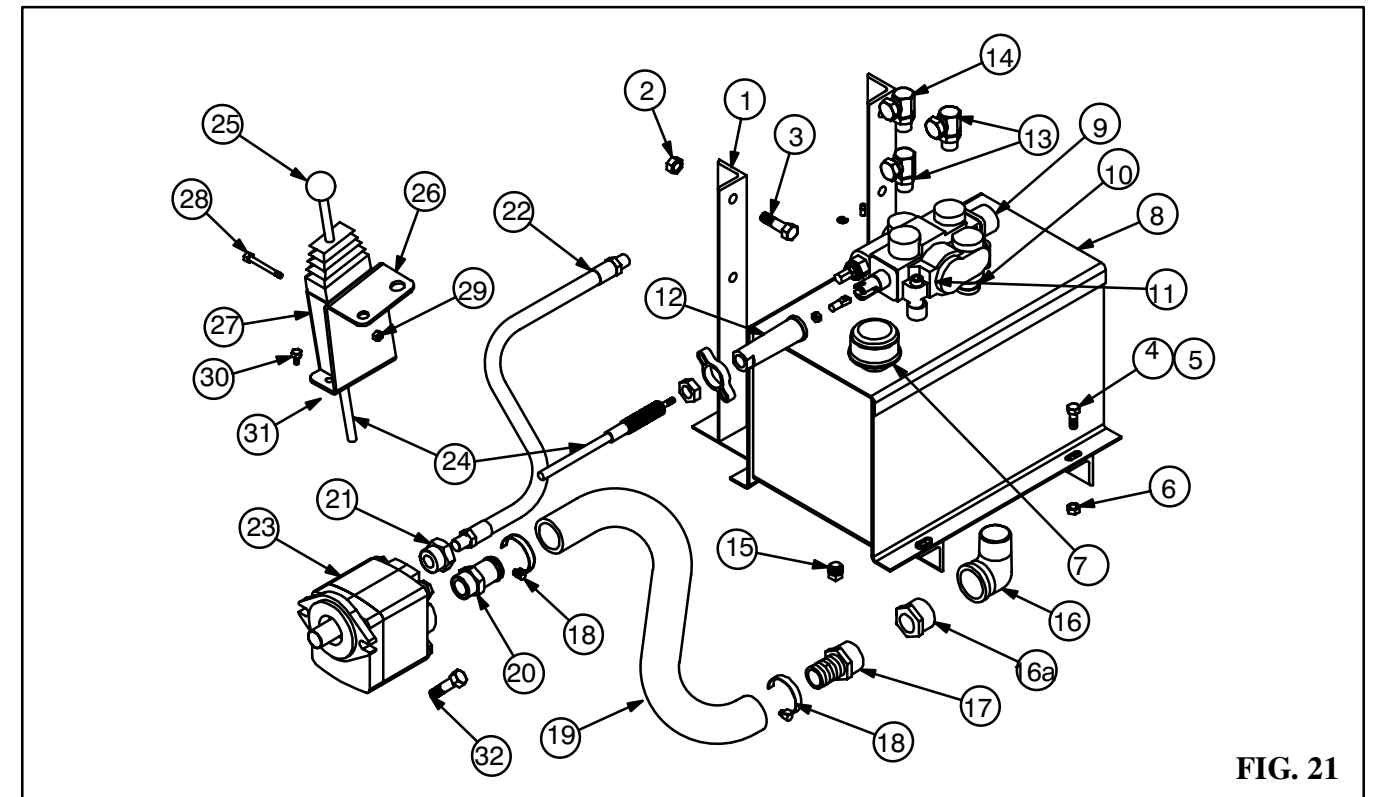

FIG. 21

ITEM	DESCRIPTION	MODEL 1900	MODEL 4400	MODELS 5500 6600 7700	QTY.
1.	Mounting Angle Assy	1621472	1621472	1621472	2
2.	Hex Lock Nut 1/2-13	1642984	1642984	1642984	4
3.	Hex Cap Screw 1/2-13 x 2	1642701	1642701	1642701	4
4.	Hex Cap Screw 3/8-16 x 1	1642714	1642714	1642714	4
5.	Flat Washer 3/8	1642732	1642732	1642732	4
6.	Hex Lock Nut 3/8-16	1643177	1643177	1643177	4
7.	Breather Cap	1644723	1644723	1644723	1
8.	Reservoir - 6 Gallon	1621925	---	---	1
	Reservoir - 8 Gallon	---	1621921	---	1
	Reservoir - 14 Gallon	---	---	1621923	1

ITEM	DESCRIPTION	MODEL 1900	MODEL 4400	MODELS 5500 6600 7700	QTY.
9.	Valve - DA 4000 PSI 7/8 ORB Ports	1643187	---	---	1
	Valve - DA 3250 PSI 7/8 ORB Ports	---	1643185		1
	Valve - SA 3250 PSI 1 1/16 ORB Ports	---	1643188	1643188	1
	Valve - DA 3250 PSI 1 1/16 ORB Ports	---		1643200	1
10.	O-Ring 0.924 ID x .116	1642922	1642922	1642922	1
11.	Soc Cap Screw 5/16-18 x 2	1643205	1643205	1643205	1
12.	Connection Kit - RVC	1643215	1643215	1643215	1
13.	Adapter 7/8 ORBM x 3/8 NPTF 90°	1642954			2
	Adapter 7/8 ORBM x 1/2 NPTF 90°		1642927		DA 2 SA 1
	Adapter 1 1/16 ORBM x 1/2 NPTF 90°			1642969	DA 2 SA 1
	Adapter 1 1/16 ORBM x 3/4 NPTF 90°			1642971	DA 2 SA 1
14.	Adapter 1 1/16 ORBM x 1/2 NPTF 90°	1642969	1642969		1
	Adapter 1 1/16 ORBM x 3/4 NPTF 90°			1642971	1
15.	Pipe Plug 3/4" Magnetic	1642794	1642794	1642794	1
16.	Pipe Elbow 3/4" Street 90°	1643226			1
	Pipe Elbow 1 1/4" Street 90°		1642975		1
	Pipe Elbow 1 1/2" Street 90°			1643227	1
16a.	Hex Bushing 1 1/2 NPT x 1 1/4 NPT			1643230	1
17.	Hose Barb 3/4 NPT x 3/4	1643017			1
	Hose Barb 1 1/4 NPT x 1 1/4		1643018	1643018	1
18.	Hose Clamp #24	1643011			2
	Hose Clamp 1 3/4 T-Bolt		1643241	1643241	2
19.	Suction Hose 3/4" ID x 6'	1643805			1
	Suction Hose 1 1/4" ID x 6'		1643806	1643806	1
20.	Hose Barb 1 1/16 ORB x 3/4	1643228			1
	Hose Barb 1 5/16 ORB x 1 1/4		1643019	1643019	1
21.	Adapter 1 1/16 ORBM x 7/8 ORBF	1283140			1
	Adapter 1 5/16 ORBM x 1/2 NPTF		1630083		1
	Adapter 1 5/16 ORBM x 3/4 NPTF			1630637	1
22.	Hose 7/8 ORB/1/2 NPT x 72 4000 PSI	1643016			1
	Hose 1/2 NPT x 72 3500 PSI		1643015		1
	Hose 3/4 NPT x 72 3000 PSI			1643153	1
23.	Pump 6 GPM ORB Ports	1644773			1
	Pump 10 GPM ORB Ports		1644774		1
	Pump 15 GPM ORB Ports			1644776	1
24.	Cable Valve Control - 96"	1643210	1643210	1643210	1
25.	Remote Valve Control	1643208	1643208	1643208	1
26.	Pedestal, Tall - RVC	1630872	1630872	1630872	1
27.	Channel, Pedestal - RVC Cover	1630873	1630873	1630873	1

ITEM	DESCRIPTION	MODEL 1900	MODEL 4400	MODELS 5500 6600 7700	QTY.
28.	Mach Screw 5/16-18 x 2 1/2 PH	1643233	1643233	1643233	3
29.	Hex Lock Nut 5/16-18	1642962	1642962	1642962	5
30.	Mach Screw 5/16 x 1/2 PH	1643329	1643329	1643329	2
31.	Clamp Plate - Pedestal	1631026	1631026	1631026	1
32.	Hex Cap Screw 1/2-13 x 1 1/4	1642726	1642726	1642726	4

Standard Valve/Tank Assembly Numbers				
Hoist Model(s)	Assy Number	Tank Size	Pressure Setting	Work Port Size
SR1900	1621944	6 Gal	4000 PSI	-10 (7/8 ORB)
SR4400 SA	1621946	8 Gal	3250 PSI	-12 (1 1/16 ORB)
SR4400 DA	1621945	8 Gal	3250 PSI	-10 (7/8ORB)
SR5500-6600-7700 SA	1621950	14 Gal	3250 PSI	-12 (1 1/16 ORB)
SR5500-6600-7700 DA	1621949	14 Gal	3250 PSI	-12 (1 1/16 ORB)

NOTES

**CRYSTEEL MANUFACTURING'S
5 YEAR CUSTOMER SATISFACTION PLEDGE
& WARRANTY**

Crysteel offers the most comprehensive warranty in the truck equipment industry. Crysteel warrants each product against defects in material and workmanship for 60 months from the in-service date.

For the full Customer Satisfaction Pledge and Warranty information, please visit our website.

<http://www.crysteel.com>



CRYSTEEL MANUFACTURING, INC.
