

OPERATOR'S MANUAL

INSTRUCTIONS and REPAIR PARTS LIST

**FOR ASSEMBLING AND OPERATING
THE LO-BOY MODEL 655 TRUCK HOIST**

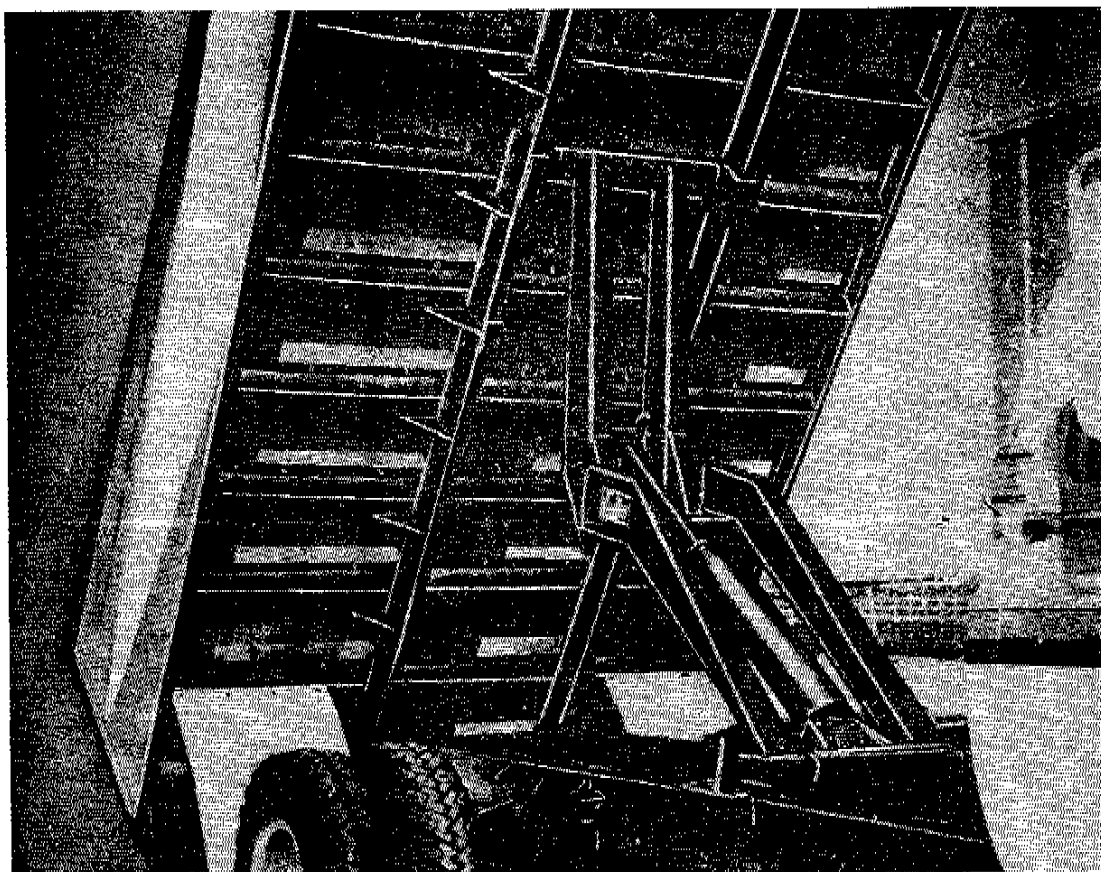

Read these instructions

Save them for reference

Crysteel Manufacturing, Inc.

Telephone: 507-726-2728

Highway 60 East
LAKE CRYSTAL, MINNESOTA 56055

LO-BOY 655 TRUCK HOIST

DATE PURCHASED _____
 SERIAL NUMBER ON HOIST _____
 SERIAL NUMBER ON CYLINDER _____
 SERIAL NUMBER ON PUMP _____

FOREWORD

This manual contains information necessary for the proper installation and operation of this truck hoist. Study it carefully before attempting to mount the hoist. With proper installation and maintenance the Lo-Boy Model 655 truck hoist will give many years of trouble free service.

When ordering parts, be sure to give serial number of both pump and cylinder. The serial number of the pump is found on the plate on the front of the pump. The serial number of the cylinder is stamped on the barrel of the cylinder near the base. For future reference, copy these numbers NOW in the space provided above. Order parts by number and description as given in the parts listing in the manual.

If you prefer, parts for the pump may be ordered directly from the manufacturer of the pump as per the information supplied with the pump, which can be considered to be part of this manual. If you do this, specify that the built-in relief valve be set to operate at 3250 P.S.I. and that your pump is part of the Lo-Boy 655 truck hoist.

THE LO-BOY MODEL 655 TRUCK HOIST IS DESIGNED AND INTENDED FOR USE ON SINGLE AXLE TRUCKS WITH CAB-TO-AXLE DIMENSIONS OF 102 INCHES THROUGH 156 INCHES AND BODY LENGTHS OF 12 FEET THROUGH 20 FEET.

KEEP THIS MANUAL IN A SAFE PLACE FOR FUTURE REFERENCE

SAFETY FIRST

NEVER EXCEED THE G.V.W. (GROSS VEHICLE WEIGHT) RATING NOR THE G.A.W. (GROSS AXLE WEIGHT) RATING SPECIFIED FOR YOUR TRUCK.

 LO-BOY 655 TRUCK HOIST

MOUNTING INSTRUCTIONS

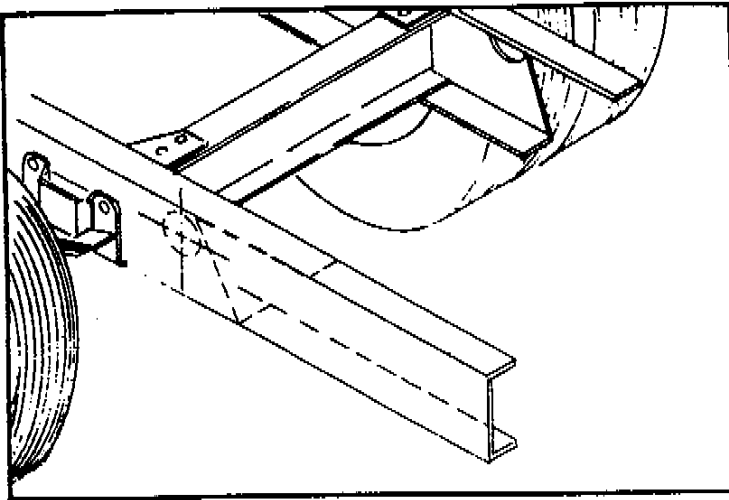

LOCATE REAR HINGE

Use the rear hinge truck frame brackets No. 4 and 6 as a guide to mark the location of the rear hinge. Mark the hole just below the top flange of the truck frame. The bracket has the correct slant on it for the angle of truck frame cut-off. The center of the rear hinge pin should be from 32 inches to 36 inches behind the center of the rear axle. If rear hinge is located more than 36 inches behind the rear axle, the truck frame must be strengthened.

TORCH-CUT HOLE AND TRUCK FRAME

Cut the frame as marked, leaving the top flange intact. It is to be bent down and welded later.

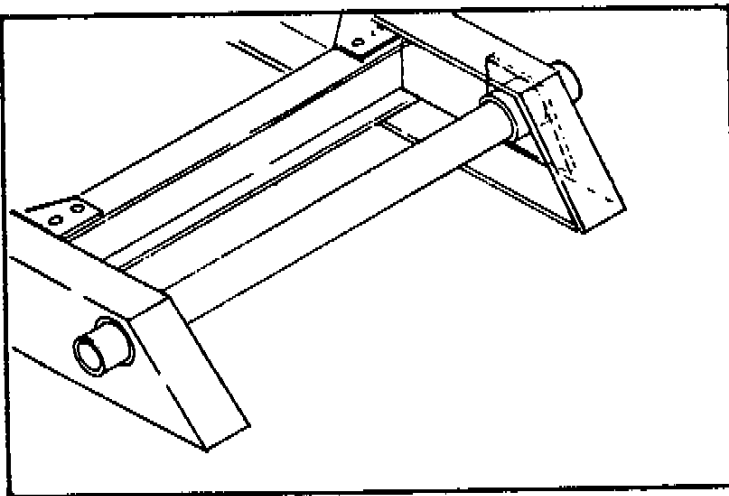

WELD BRACKETS TO TRUCK FRAME

Install the truck frame brackets No. 4 and 6 on the rear hinge pin No. 5 for alignment. Weld them to truck frame at all contact points. Bend the top flange of the truck frame down and weld in place. Be sure to weld the top flange of the truck frame to the bracket tube.

 CRYSTEEL MANUFACTURING, INC.

LO-BOY 655 TRUCK HOIST

LOCATE HOIST ON TRUCK FRAME

The rear end of the main hoist frame No. 10 is designed to rest on the truck frame crossmember that supports the forward spring shackle, or the next crossmember farther forward. The off-set pivot of the hoist frame fits down into the truck frame behind the crossmember as shown.

Measure forward from the center of the rear hinge pin to the center of the upper crosstube of the hoist. The following dimension "D" from the rear hinge to the lift point will provide the corresponding dump angle:

140 inches - 40 degrees	112 inches - 50 degrees
132 inches - 42 degrees	108 inches - 52 degrees
124 inches - 45 degrees	106 inches - 53 degrees
116 inches - 48 degrees	104 inches - 55 degrees

Center the hoist in the truck frame and make certain it is square with the truck frame.

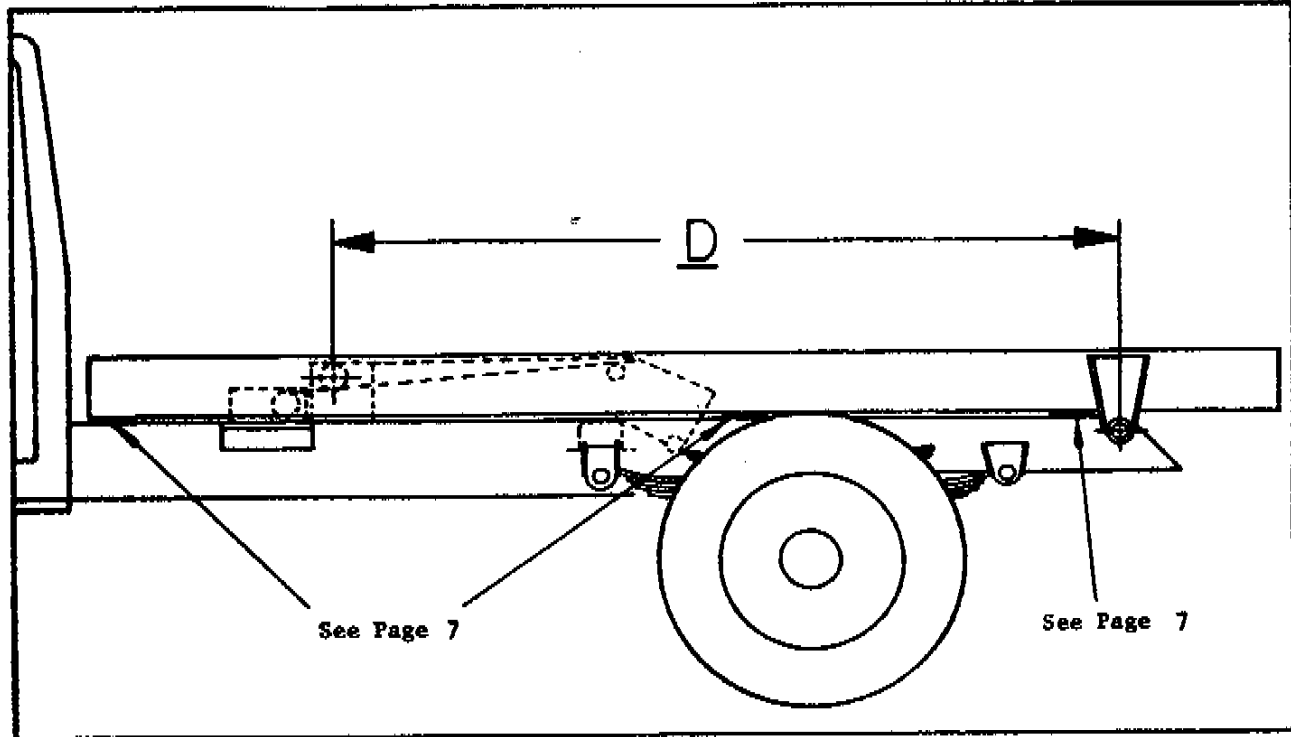

LO-BOY 655 TRUCK HOIST

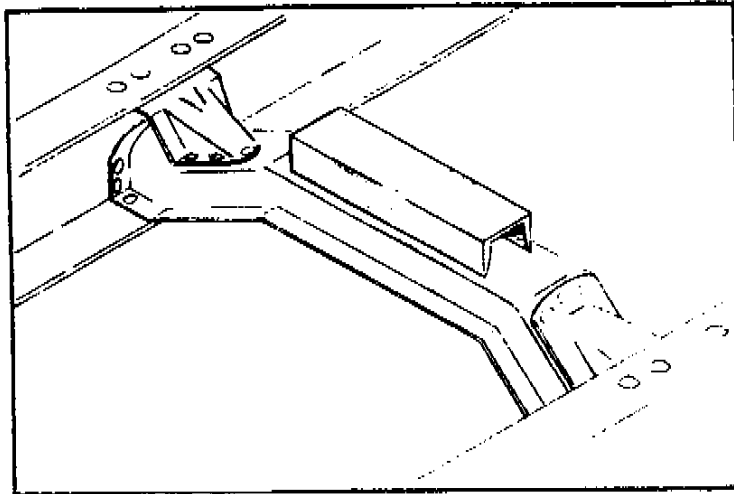

SPECIAL INSTRUCTIONS FOR SOME INSTALLATIONS

1. On certain models of Chevrolet and GMC trucks, the truck frame crossmember at the forward spring shackle is lower than the frame. In this case, weld a short length of three inch channel iron on top of this crossmember as shown, to support the hoist.
2. On some trucks it will be necessary to reshape the vacuum lines to the two speed axle, to clear the hoist.

MOUNT HOIST TO TRUCK FRAME

The angle mounting brackets must rest flat on truck frame. If rivets are encountered in truck frame, and hoist cannot be moved to clear them, counter-sink the rivet heads into the brackets. Center the mounting angles No. 12 under the brackets, clamp them in place and drill $21/32$ holes in truck frame. Bolt mounting angles to truck frame with $5/8$ by $1-3/4$ machine bolts and lockwashers. CAUTION: When drilling in truck frame, be careful of brakelines, wiring, etc. inside the truck frame.

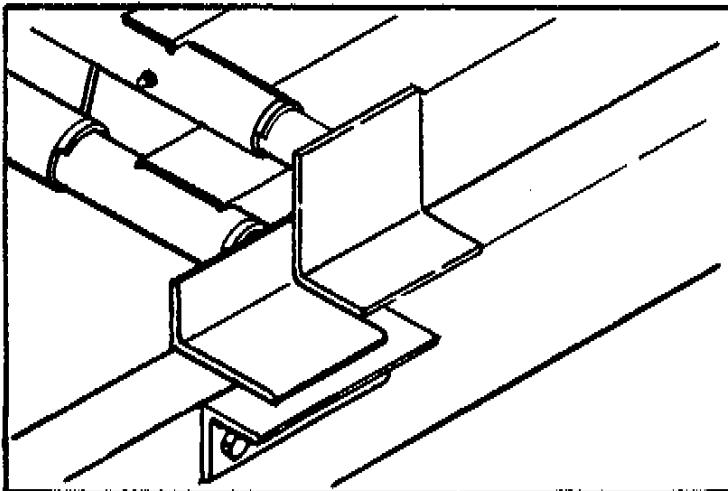

WELD BRACKETS TO MOUNTING ANGLES

Recheck to make sure hoist is square with truck frame. Weld brackets very securely to mounting angles.

LO-BOY 655 TRUCK HOIST

PLUMBING AND USE OF TEFLON TAPE

Use teflon tape on all hydraulic connections. Properly done, this will assure absolutely leakproof connections. All connections are pipe thread. One wrap of teflon tape is enough - - use it sparingly. Rather than cutting, break off about 2 inches of teflon tape. This will provide a feathered edge, for easier assembly. Stretch it tight so that it sinks deeply into the threads. Be sure to wrap the tape in the same direction the fitting screws on so it will stay in place as the fitting is threaded on. It is not necessary to tighten the connections excessively.

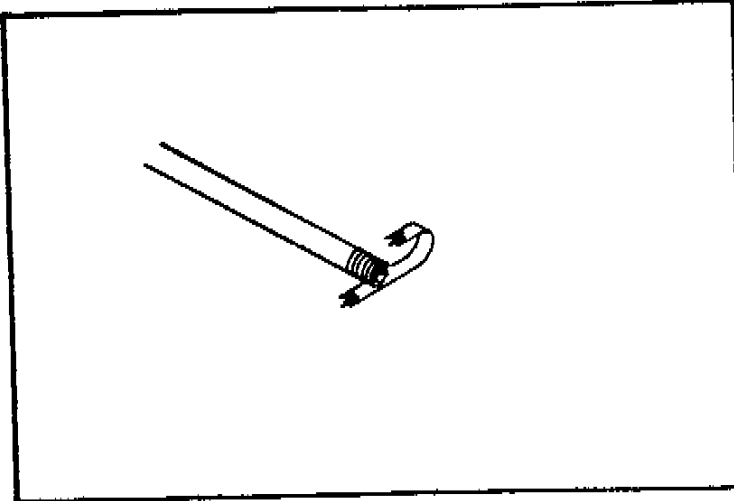

ATTACH MOUNTING ANGLES TO PUMP

Determine on which side of the truck frame to mount the pump. (Same side as the PTO). Bolt the pump mounting angles No. 21 to the pump No. 15, using 3/8 by 1 machine bolts, flat washers and lock washers.

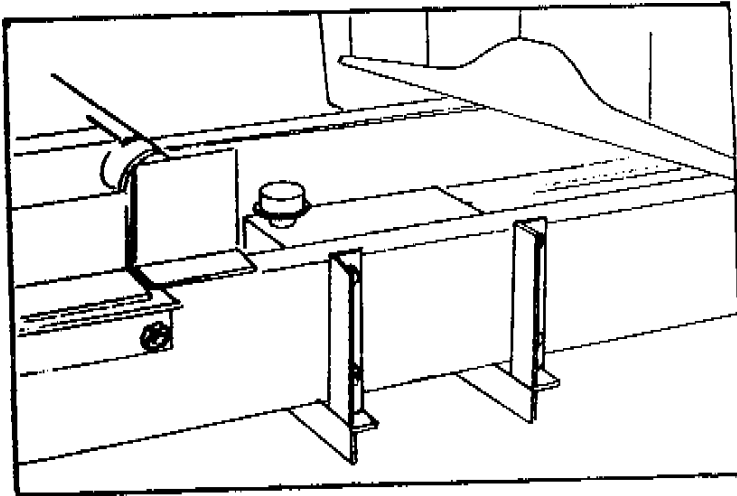

MOUNT HYDRAULIC PUMP

Temporarily clamp the pump mounting angles to the truck frame, with the pump inside the truck frame a few inches behind the cab. Check to be sure of sufficient clearance and that PTO drive-shaft is long enough. In some cases it may be necessary to re-work the exhaust system for clearance. UNDER NO CIRCUMSTANCES SHOULD THE ENGINE EXHAUST BE PERMITTED TO BLOW DIRECTLY ONTO THE PUMP. The PTO driveline must never exceed 15 degrees angularity. After locating the pump, drill 17/32 diameter holes in the truck frame and bolt tight, using 1/2 by 1-1/2 inch machine bolts and lock washers.

CRYSTEEL MANUFACTURING, INC.

-5-

 LO-BOY 655 TRUCK HOIST

ADD HYDRAULIC FLUID - 5 U.S. GALLONS

The capacity of the pump reservoir is 27 U.S. quarts. Five gallons of hydraulic fluid are required for operation. **KEEP IT CLEAN!!! USE CLEAN CONTAINERS, FUNNELS AND OTHER EQUIPMENT.** Use a high quality hydraulic fluid of 150 SSU @ 100 degrees F. which contains corrosion and oxidation inhibitor and a foam depressant. For general use, a high quality SAE 10W non-detergent motor oil with the proper additives, or type A automatic transmission fluid can be used.

COMPLETE HYDRAULIC PLUMBING

Install a street elbow into each valve port on top of the pump. Connect the 48 inch hose No. 13 to the valve port nearest the rear, and to the cylinder port at the base of the cylinder. Connect the 60 inch hose No. 14 to the front valve port and to the head end cylinder port. On trucks with C.A. dimension longer than 120 inches, order the correct hose kit to extend hoses so they will reach.

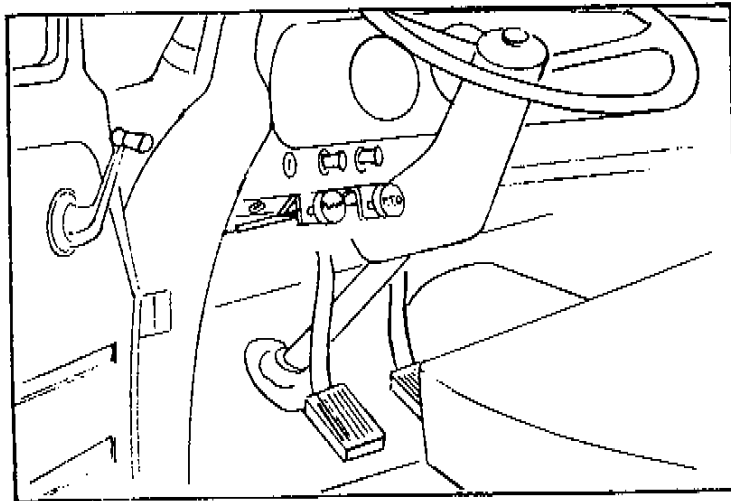

REMOVE control wire from cable housing and oil inside of cable housing before installing. Attach control mounting angle No. 36 at a convenient location under the dash, by drilling and bolting with 1/4 by 3/4 machine bolts and lock washers. Install cable through firewall and connect to valve control lever. Check and adjust for proper operation. Be sure there are no sharp bends in cable.

 CRYSTEEL MANUFACTURING, INC.

-6-

LO-BOY 655 TRUCK HOIST**INSTALL PTO DRIVELINE**

Install the long U-slip joint No. 19 on the pump drive-shaft, and the short U-joint No. 18 on the PTO driveshaft so that the inner edge of the hub of each is flush with the end of the shaft. DO NOT TIGHTEN SETSCREWS. Measure the exact length of the square driveshaft No. 17 needed between the two joints so that the shaft will be flush with the inner edge of both hubs. Cut the square driveshaft to proper length with a hacksaw and grind off any burr. Insert shaft into the slip joint hub. Slide both joints farther onto the shafts, and insert the square driveshaft into the short U-joint hub. Relocate the joints in their proper position. Tighten the setscrews very tight and secure with a safety wire.

INSTALL TRUCK BODY

Assuming that seven or eight inch longbeams are attached to the body, place the body in position on the truck WITH AT LEAST TWO INCHES OF CLEARANCE BEHIND THE CAB. Use the rivet strip mounting pads No. 8 between longbeams and truck frame. Use three on each side, spaced as seen on page 3. Weld them to the underside of the longbeams as shown. Align body longbeams carefully with the truck frame.

LO-BOY 655 TRUCK HOIST

ATTACH REAR HINGE LONGBEAM BRACKETS

Install the rear hinge pin No. 5 in place and clamp the rear hinge longbeam brackets No. 2 and 3 to the longbeams. Align them carefully and weld them very securely to the longbeams as shown. Normally, the brackets will lay flat on the longbeams, but if the truck frame has been reinforced and is over-width, it will be necessary to shim between the brackets and the longbeams with a flat plate of proper thickness. Install the 3/8 by 3 inch cotter pin through the hinge pin.

SINCE THIS IS USUALLY QUITE A PERMANENT INSTALLATION, IT IS ADVISABLE TO ALSO WELD THE HINGE PIN TO BOTH LONGBEAM BRACKETS WITH SMALL WELDS THAT CAN BE BROKEN LOOSE IF NEED BE IN THE FUTURE.

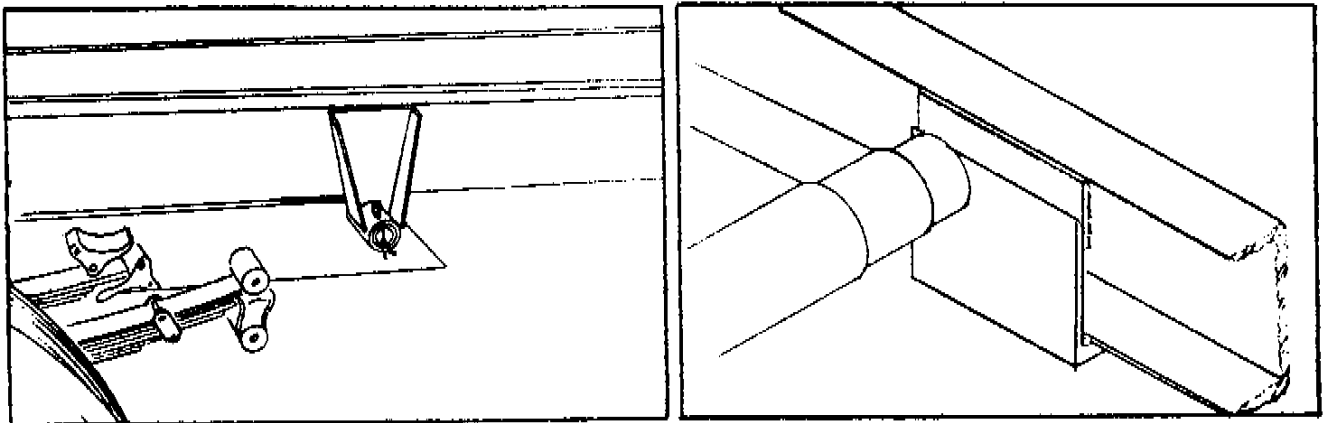

ATTACH LONGBEAMS TO HOIST LIFT BRACKETS

Weld the longbeams securely to the angle lift brackets of the hoist. On the inside of the longbeams, use the flat spacer No. 1 to connect the upper flange of the longbeam channel to the lift bracket as shown. Weld the flat spacer securely to both the bracket and the flange of the longbeam. The spacer can be used with either seven inch or eight inch channel longbeams.

THESE SPACERS ARE VERY IMPORTANT. PLEASE MAKE CERTAIN THAT THEY ARE INSTALLED PROPERLY.

LO-BOY 655 TRUCK HOIST

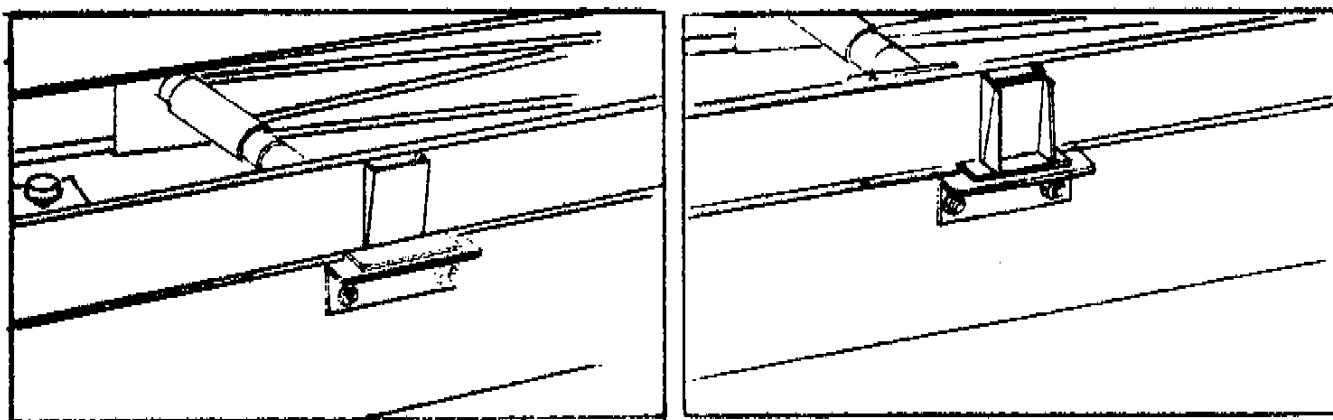
**INSTALL BODY GUIDES**

The four body guides No. 11 are all identical. Weld one to each longbeam as shown, with the wide end of the body guide at the top and centered over the truck mounting brackets. Now weld the other pair of body guides to the truck mounting brackets, and tight against the first body guides as shown. There should be NO sideplay between body guides when the truck body is in the lowered position.

LUBRICATION INSTRUCTIONS (SEE PAGE -10-)

Install and lubricate grease zerks in the following locations:

- A - Truck mount pivot pin --- 2 fittings
- B - Longbeam pivot pin ----- 2 fittings
- C - Main Center hinge ----- 1 fitting
- D - Cylinder pivots ----- 2 fittings
- E - Rear hinge ----- 2 fittings
- F - U-slip joint ----- 1 fitting
- G - Each U-joint ----- 2 fittings (These are already installed)

Lubricate all fittings at regular intervals, at least each time the truck chassis is lubricated. There are tremendous forces on the bearing surfaces within the hoist frame, especially the main center hinge and cylinder crosshead. It pays to be generous with the grease gun, to insure proper operation and long life.

LO-BOY 655 TRUCK HOIST

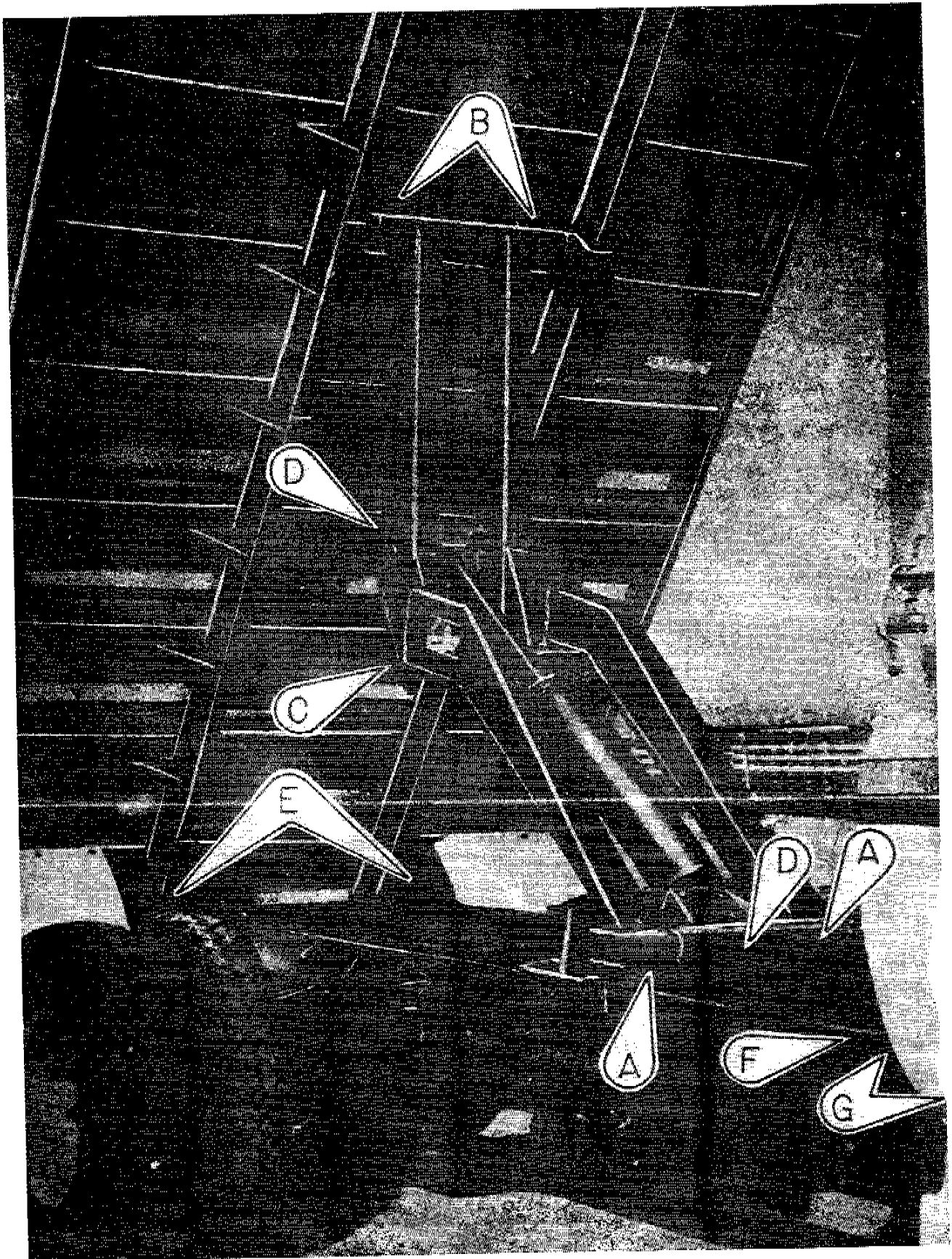

CRYSTEEL MANUFACTURING, INC.

LO-BOY 655 TRUCK HOIST

12 VOLT ELECTRIC HYDRAULIC POWER UNIT

Special Instructions to Install Monarch Electric pumps with Model 445, 545, 645, 655, and ST-560 LO-Boy hoists.

1. Mount pump unit just ahead of hoist between frame rails of truck or trailer.
2. Mount control cable under the dash or in a convenient place in the cab. For trailers, mount control cable to a suitable bracket near front of trailer. Connect cable to pump valve control with small parts supplied.
3. Mount push-button switch just above control cable so one hand can operate both cable and push button.
4. The solenoid on the MONARCH pump will energize the pump motor when the small terminal on the solenoid is grounded. Connect one terminal of the push-button switch to ground and the other terminal to the solenoid. Connect battery cable to the heavy terminal on the solenoid. For trailers, use a heavy duty coupler of the type used for welding cable extensions to disconnect the battery cable at the trailer hitch.
5. For trailers, install a separate heavy duty ground cable that can be disconnected at the trailer hitch. DO NOT depend on the hitch to carry the ground connection.
6. IMPORTANT - On all electric installations, install a heavy duty ground cable from the truck battery direct to the truck frame. The light cable normally used from the engine to the frame is not heavy enough. Recommended battery cable size is No. 0. Never, under any circumstance, use cable lighter than No. 1.

Monarch Model 310 - Double acting (2 types
12" reservoir (445), 3 gal. approx., 3600 P.S.I.
22" reservoir (545 through ST-560), 6 gal. approx.,
3250 P.S.I.

LO-BOY 655 TRUCK HOIST

OPERATION AND USE

1. Engage PTO from cab and adjust engine speed to fast idle.
2. If hydraulic plumbing is correct, hoist should raise when pump knob is out, hold when knob is centered, and lower with knob in.
3. Cycle the hoist several times to remove air from the cylinder and hydraulic lines.
4. When hoist cylinder reaches the end of it's stroke, oil will by-pass through the relief valve. Do not permit this for any length of time as it places unnecessary strain on the hydraulic system. Put pump knob in hold position or disengage the PTO.
5. It is advisable to run the PTO to lower the hoist because this will act as a hydraulic lock to hold the hoist closed. It is not necessary to do this, however, because the reservoir has sufficient capacity whether you pump the oil back into the cylinder or not, but you will not benefit from the advantages of double action.
6. To make use of the hydraulic lock feature, place knob in center hold position after hoist is pumped all the way down; this places the pressure on the valve where it belongs, not on the pump.
7. DO NOT LEAVE THE PTO IN GEAR WHILE TRANSPORTING. THIS WILL CAUSE SEVERE DAMAGE TO THE HYDRAULIC PUMP AND/OR DRIVE-LINE.
8. The hydraulic system should be drained, flushed, and refilled with proper hydraulic fluid at regular intervals.

CAUTION: NEVER USE HYDRAULIC BRAKE FLUID IN THE HYDRAULIC SYSTEM.

CAPACITY CHART FOR LO-BOY MODEL 655 HOIST Level Load Capacity in Tons

The capacity of any hoist will vary according to the C.A. dimension of the truck, body length, rear overhang and dump angle.

C.A. length	Body length	Capacity 45°	50°	55°
102"	13'6"	22 tons	20 tons	18.5 tons
102"	15'	26	24	22
108"	14'	21	18.5	17.5
108"	15'	23.5	21	19.5
114"	14'	19	17	15.5
114"	15'	21	18.5	17.5
120"	15'	19	17	15.5
120"	16'6"	22	20	18.5
126"	15'	17	15	14
126"	16'6"	20	17.5	16.5
138"	16'6"	16	14.5	13.5
138"	18'	19	17	15.5
144"	18'	17	15	14
144"	19'6"	20	17.5	16.5
150"	18'	15.5	14	13
150"	19'6"	18	16	15
156"	18'	14.5	13	12
156"	20'	17	15	14

LO-BOY 655 TRUCK HOIST

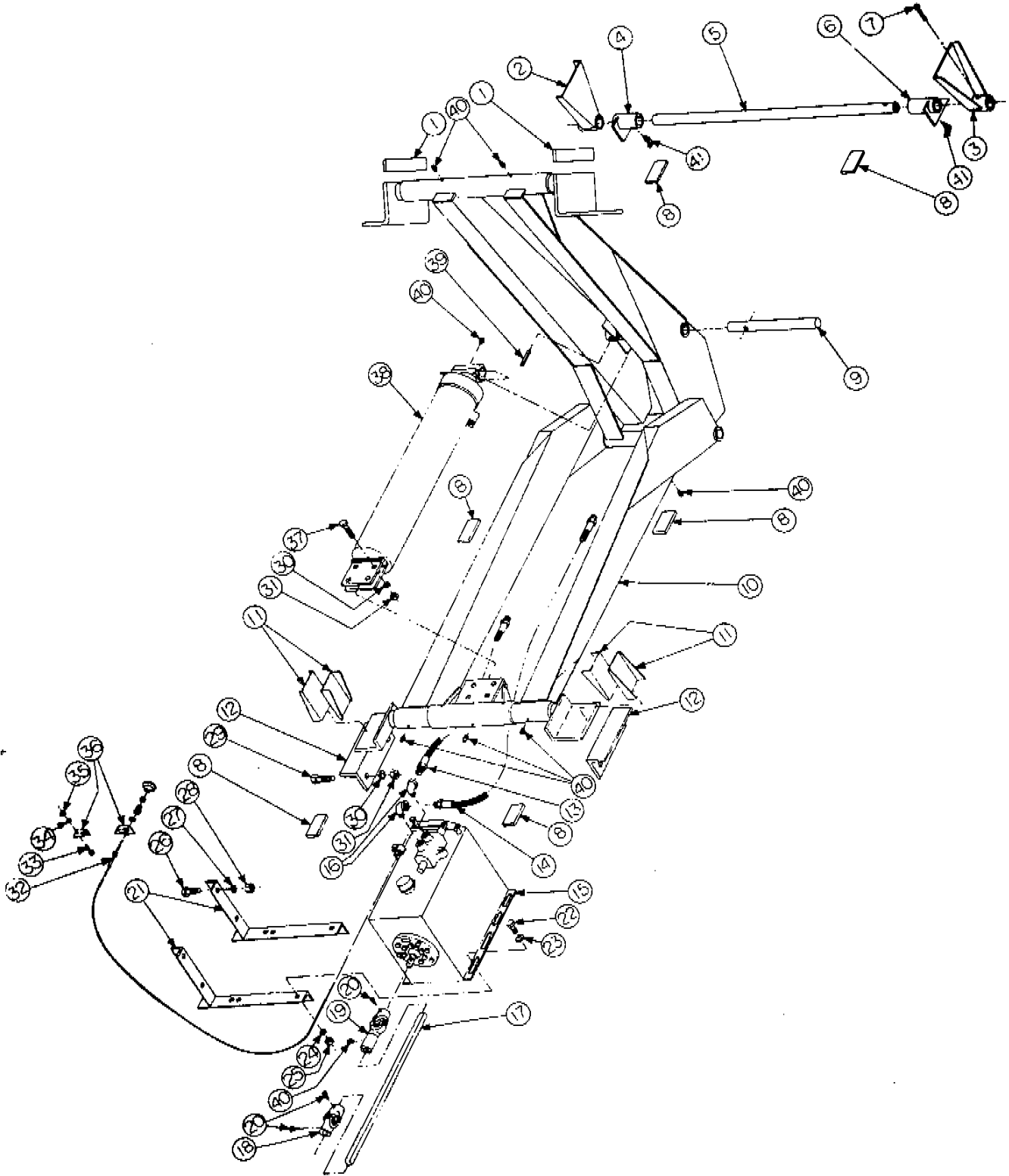

CRYSTEEL MANUFACTURING, INC.

LO-BOY 655 TRUCK HOIST

PARTS LIST

KEY NO.	PART NO.	DESCRIPTION	QUANTITY
1	200896	Flat spacer 3/8 x 2 x 7	2
2	100176	Rear hinge longbeam bracket	1
3	100172	Rear hinge longbeam bracket	1
4	100167	Rear hinge truck bracket, right	1
5	202218	Rear hinge pin	1
6	100165	Rear hinge truck bracket, left	1
7	400210	3/8 x 3 Cotter pin	1
8	200890	Rivet strip 1/2 x 2 x 4	6
9	201173	Cylinder cross head shaft	1
10	100329	Main hoist frame	1
11	201415	Body guide	4
12	201422	Mounting angle	2
13	400512	3/8 Hydraulic hose, 36 inch	1
14	400515	3/8 Hydraulic hose, 60 inch	1
15	400317	Hydraulic pump & reservoir, 8 piston	1
16	400412	3/8-90 degree elbow street	2
17	200885	PTO driveshaft, 7/8 sq. x 4 ft.	1
18	400578	Standard short U-joint	1
19	400583	Long U-slip joint	1
20	400102	3/8 x 1/2 setscrew, drilled head	3
21	100511	Pump mounting angle	2
22	400121	3/8 x 1 N.C. cap screw	4
23	400164	3/8 flat wrought washer	4
24	400162	3/8 Lock washer	4
25	400183	3/8 N.C. hex nut	4
26	400100	5/8 x 1-3/4 N.C. cap screw	4
27	400160	5/8 lock washer	4
28	400181	5/8 N.C. hex nut	4
29	400104	1/2 x 1 3/4 N.C. cap screw	4
30	400161	1/2 lock washer	8
31	400182	1/2 N.C. hex nut	8
32	400025	Pump control cable, 12 ft.	1
33	400101	1/4 x 3/4 N.C. cap screw	4
34	400163	1/4 lock washer	4
35	400184	1/4 N.C. hex nut	4
36	201391	Dash control mounting angle	2
37	400102	1/2 x 2 N.C. cap screw	4
38	104237	Cylinder assembly	1
39	400208	7/16 x 2-1/2 double roll pin	1
40	400103	1/8-27 Straight grease fitting	8
41	400117	1/8-27 90 degree grease fitting	2

 LO-BOY 655 TRUCK HOIST

OPTIONAL PARTS LIST

PART NO.	DESCRIPTION	REPLACES KEY NO.	QUANTITY
400319	Hyd. pump & res. 8 GPM 2 valves	15	1
400320	Hyd. pump & res. 12 GPM 1 valve	15	1
400322	Hyd. pump & res. 12 GPM 2 valves	15	1
400334	Electric pump unit	15	1
100174	Pump mounting angle - for Elect. pump	21	2
400517	Hyd. hose extension - 12" long		2
400518	Hyd. hose extension - 24" long		2
400519	Hyd. hose extension - 42" long		2

SOME DO'S AND DON'TS FOR SAFETY AND LONG SERVICE LIFE

1. Use the proper hydraulic fluid. KEEP IT CLEAN. Remember to change it regularly. See page 6.
 2. Lubricate all grease fittings at regular intervals. See page 10.
 3. ALWAYS BLOCK UP THE HOIST BEFORE WORKING UNDER IT.
 4. Do not race the engine when unloading.
 5. Do not overload the hoist beyond it's capacity.
 6. DO NOT TAMPER WITH THE HYDRAULIC RELIEF VALVE. This will void the warranty. It can cause severe damage to hoist and cylinder.
 7. NEVER LEAVE THE PTO IN GEAR WHILE TRANSPORTING, IT WILL RUIN THE HYDRAULIC PUMP.
 8. Check all bolts and setscrews regularly. Keep them tight.
-

CAPACITY FORMULA FOR LO-BOY MODEL 655 HOIST

To determine the capacity of the Lo-Boy Model 655 Hoist for applications other than those shown on the capacity chart, use the following formula:

- (1) Measure the distance in inches from center of the rear hinge pin to the center of the body. Call this dimension "A".
 - (2) Measure the distance in inches as shown on page 4, from the center of the rear hinge pin to the center of lift point. This is dimension "D".
 - (3) Multiply dimension "D" by 18.
 - (4) Divide this total by dimension "A". Result will be the level load capacity of the hoist in thousands of pounds, including body weight.
-

CRYSTEEL MANUFACTURING, INC.

Highway 40 East

LAKE CRYSTAL, MINNESOTA 56055

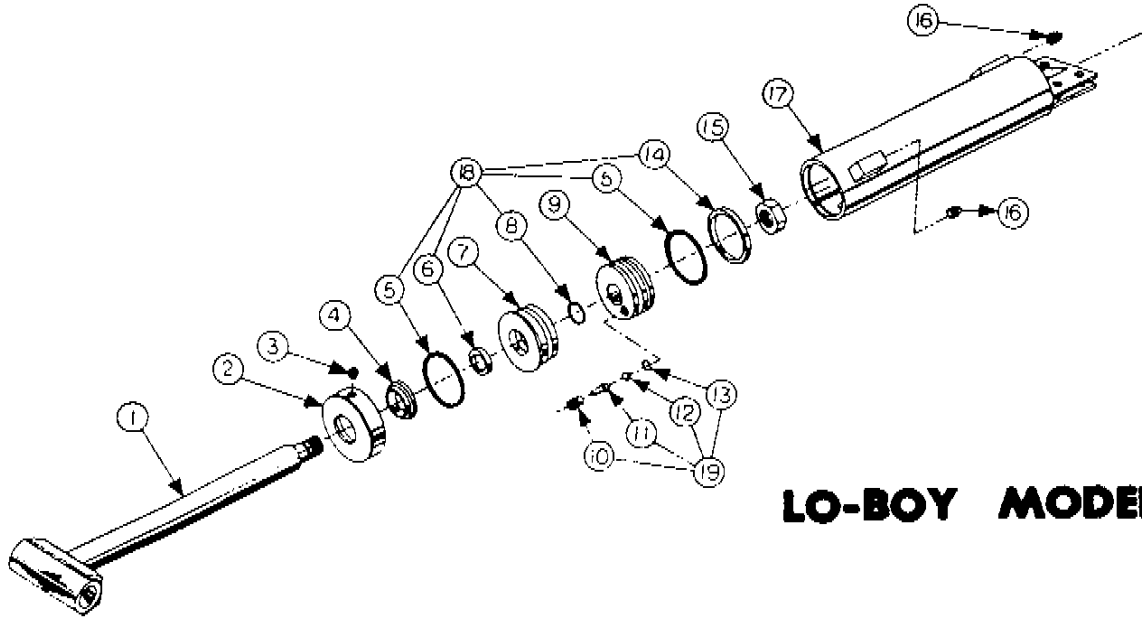

LO-BOY MODEL 655

CYLINDER PARTS LIST MODEL 655 (SERIAL NUMBER 2-655-001 AND UP)

KEY NO.	PART NO.	DESCRIPTION	QUANTITY
1	104274	Cylinder Shaft Assembly	1
2	104275	Cylinder Cap Assembly	1
3	400149	Set Screw 1/4x3/16, Nylon tip	1
4	400915	Wiper Seal, 2 3/8 inch	1
5	400258	O-Ring 5 1/2 x 6	2
6	400908	Poly Seal 2 3/8 x 2 5/8	1
7	205104	Head	1
8	400255	O-Ring 1 1/2 x 1 5/8	1
9	105190	Piston with Bypass Valve	1
10	400978	Valve Plug	1
11	400979	Valve Pin	1
12	400013	Ball 3/8	1
13	401017	O-Ring	1
14	400257	Poly Seal 5 1/2 x 6	1
15	400200	Lock Nut 1 1/2	1
16	400422	Pipe Plug 3/8	2
17	104272	Cylinder Tube Assembly	1
18	105184	Seal Kit	
19	105185	Valve Kit	

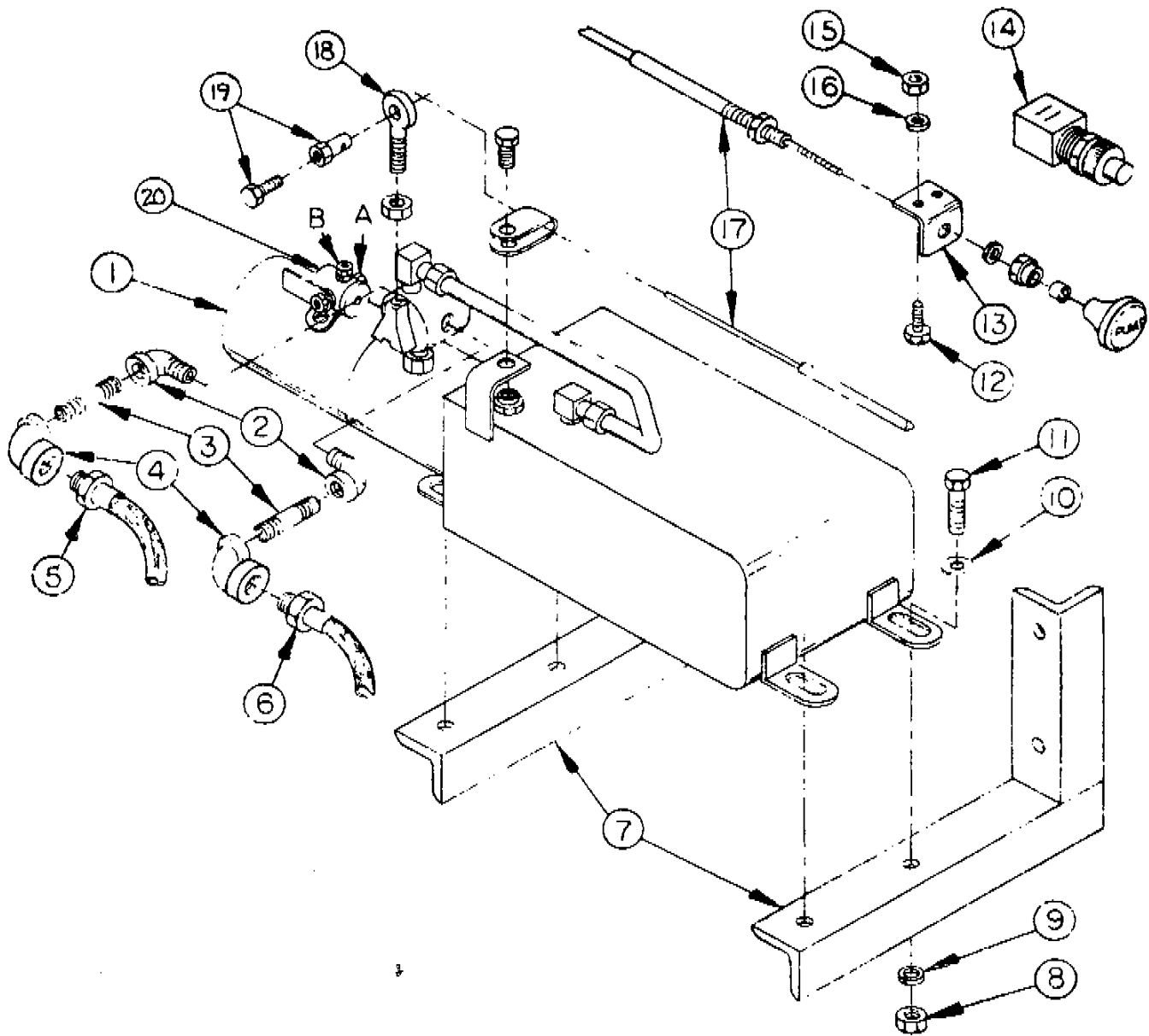

655 ELECTRIC HYDRAULIC PUMP

Key No.	Part No.	Description	Qty.
1	400334	Electric Pump	1
2	400423	1/4 90° Street Elbow	2
3	400420	1/4x1 1/2 Pipe Nipple	2
4	400421	1/4x3/8 Pipe Elbow	2
5	400515	3/8 Hyd. Hose, 60 Inch	1
6	400512	3/8 Hyd. Hose, 36 Inch	1
7	100174	Pump Mounting Bracket	2
8	400183	3/8-16 Plain Hex Nut	4
9	400162	3/8 Lockwasher	4
10	400164	3/8 Flat Washer	4
11	400121	3/8-16x1 Cap Screw	4
12	400101	1/4-20x3/4 Cap Screw	2
13	201391	Control Cable Bracket	1
14	400051	Push Button Switch	1
15	400184	1/4-20 Plain Hex Nut	2
16	400163	1/4 Lockwasher	2
17	400025	12' Control Cable	1
18	400145	Eye Bolt	1
19	400741	Control Cable Clamp	1
20	400062	Solenoid	1

CRYSTEEL TRUCK BODY PROP

Crysteel's Truck Body Prop is designed and intended for use to support any empty truck body in the raised position to permit service work to be performed safely beneath a raised body. As a general rule, one prop will support a dump body of 12 feet or less in length, or a farm type body of 16 feet or less. With longer bodies two props should be used, one on each side. The Truck Body Prop is adaptable for use with any conventional body with six inch through nine inch longbeams and three inch or higher crossmembers.

Installation of Truck Body Prop

Refer to cross-sectional drawings as shown below:

1. Raise body to desired height and brace it securely or support it with overhead equipment before beginning installation.
2. Position body prop arm pad on top of longbeam between body crossmembers a few feet ahead of rear hinge, so that the operator will be just ahead of rear wheels when reaching for body prop handle; or with tandem axle trucks, he will be between the tandem axles.
3. Position pivot bracket of prop against longbeam near the bottom flange and weld securely in place. Make sure that prop arm will clear top of truck frame by at least two inches when swung into support position later.
4. Pull on handle of prop arm to compress spring and apply light coating of grease to lubricate pivot tube.
5. To operate Truck Body Prop, raise body to desired height, shut off all power, grasp prop handle at arms length and pull to compress spring. Prop arm will swing down by gravity, and spring will push prop into support position. Lower body slowly until prop contacts truck frame. **DO NOT POWER HOIST DOWN!!!!!!!!!!!!**
6. To place Truck Body Prop in storage position simply reverse the above procedure.

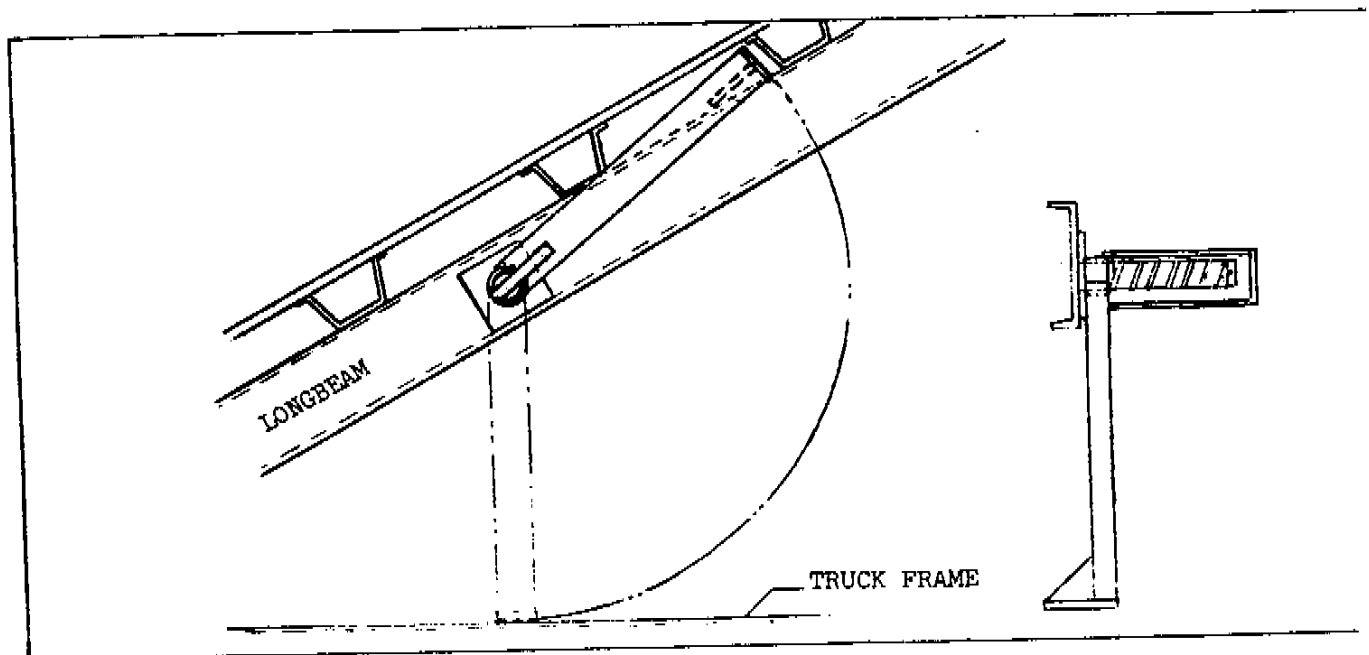

CRYSTEEL MANUFACTURING, INC.

LO-BOY 655 TRUCK HOIST

WARRANTY

WARRANTY

Crysteel Manufacturing, Inc., warrants its products for a period of one year from date of purchase.

The warranty provides that our products must perform satisfactorily or we will repair, replace, or refund the purchase price at the option of the purchaser. Hydraulic pumps, valves, hoses, and other purchased parts are covered by the warranties of their respective manufacturers.

Any parts returned to Crysteel Manufacturing, Inc. shall be shipped prepaid, and will be returned F.O.B. Lake Crystal, Minnesota.

We will not assume responsibility for shipping, labor, or travel expenses.

The warranty is void if the product has been obviously abused, or subjected to other than normal usage.

We reserve the right to make improvements without notice or obligation regarding models previously sold.

*SPECIALLY DESIGNED —
WITH QUALITY IN MIND*

CAUTION

- BODY MUST BE BRACED BEFORE SERVICING HOIST OR WORKING IN AREA WITH BODY IN RAISED POSITION
- LUBRICATE HOIST GREASE FITTINGS OFTEN - AT LEAST EACH TIME TRUCK IS SERVICED
- TRUCK MUST BE LEVEL FOR DUMPING
- DO NOT OVERLOAD

CRYSTEEL MFG., INC.



HIGHWAY 60 EAST • LAKE CRYSTAL, MINNESOTA 56055 • TELEPHONE 507-726-2728